

Installation & Maintenance Instructions

BA507E-SS, BA527E-SS



Supplied by

247cable.com

Call us on +44 (0)118 916 9420 | Email info@247able.com



Installation & Maintenance Instructions

BA507E-SS & BA527E-SS

Rugged general purpose loop-powered panel mounting indicators

BEKA
associates

Reading Office
Cutbush Park, Danehill, Lower Earley,
Reading, Berkshire. RG6 4UT. UK.
Tel: +44 (0)118 9311188
Email: info@able.co.uk

Aberdeen Office
Unit 6 Airside Business Park, Kirkhill Industrial Estate,
Dyce, Aberdeen. AB21 0GT. UK.
Tel: +44 (0)1224 725999
Email: ab@able.co.uk

Internet: www.able.co.uk
e-procurement: www.247able.com
Registered in England No: 01851002
VAT No: GB 417 2481 61



BA507E-SS & BA527E-SS
Rugged general purpose
loop-powered
panel mounting indicators
Issue 1

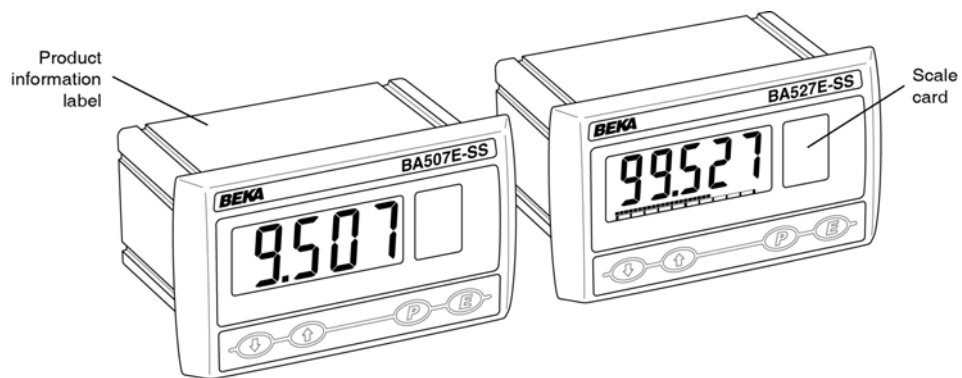

CONTENTS

- 1. Description**
- 2. Operation**
 - 2.1 Controls
- 3. Applications**
 - 3.1 Transmitter loops
 - 3.2 Remote indication
- 4. Installation**
 - 4.1 Location
 - 4.2 Installation procedure
 - 4.3 Indicator earthing
 - 4.4 EMC
 - 4.5 Scale card
- 5. Configuration and Calibration**
 - 5.1 Summary of configuration functions.
 - 5.2 Indicator function
 - 5.3 Resolution
 - 5.4 Position of decimal point
 - 5.5 Calibration using an external current source.
 - 5.6 Calibration using internal reference.
 - 5.7 Bargraph format and calibration
 - 5.8 Function of the *P* push button
 - 5.9 Tare function
 - 5.10 Security code
 - 5.11 Reset to factory defaults
 - 5.12 Under and over-range
- 6. Lineariser**
 - 6.1 Lineariser calibration using an external current source.
 - 6.1.1 Example, adding break-points to a new indicator.
 - 6.2 Lineariser calibration using internal reference.
 - 6.2.1 Example, adding break-points to a new indicator.
 - 6.3 Under and over-range
 - 6.4 Lineariser default configuration
- 7. Maintenance**
 - 7.1 Fault finding during commissioning
 - 7.2 Fault finding after commissioning
 - 7.3 Servicing
 - 7.4 Routine maintenance
 - 7.5 Guarantee
 - 7.6 Customer comments
- 8. Accessories**
 - 8.1 Scale card
 - 8.2 Tag information
 - 8.3 Alarms
 - 8.3.1 Solid state output
 - 8.3.2 Configuration and adjustment.
 - 8.3.3 Alarm enable
 - 8.3.4 Setpoint adjustment
 - 8.3.5 Alarm function
 - 8.3.6 Alarm output status
 - 8.3.7 Hysteresis
 - 8.3.8 Alarm delay
 - 8.3.9 Alarm silence time
 - 8.3.10 Flash display when alarm occurs.
 - 8.3.11 Access setpoint in display mode.
 - 8.3.12 Adjusting alarm setpoints from the display mode.
 - 8.3.13 Displaying setpoints on bargraph.
 - 8.4 Display backlight
 - 8.4.1 Loop powering the backlight
 - 8.4.2 Separately powering the backlight.

1. DESCRIPTION

These rugged panel mounting, general purpose digital indicators display the current flowing in a 4/20mA loop in engineering units. They are loop powered but only introduce a 1.2V drop which allows them to be installed into almost any 4/20mA current loop. No additional power supply or battery is required.

The two models are electrically similar, but have different displays.

| Model | Display |
|-----------|---|
| BA507E-SS | 4 digits 15mm high |
| BA527E-SS | 5 digits 11mm high and 31 segment bargraph. |

This instruction manual supplements the instruction sheet supplied with each instrument.

The main application of both models is to display a measured variable or control signal in a process area. The indicators have a rugged stainless steel case with IP66 front of panel ingress and impact protection allowing them to be installed in environments where they are liable to be impacted. The zero and span of the display are independently adjustable so that the indicator can be calibrated to display any variable represented by the 4/20mA input current, e.g. temperature, flow, pressure or level.

2. OPERATION

Fig 1 shows a simplified block diagram of both models. The 4/20mA input current flows through resistor R1 and forward biased diode D1. The voltage developed across D1, which is relatively constant, is multiplied by a switch mode power supply and used to power the instrument. The voltage developed across R1, which is proportional to the 4/20mA input current, provides the input signal for the analogue to digital converter.

Each time a 4/20mA current is applied to the instrument, initialisation is performed during which all segments of the display are activated, after five seconds the instrument displays the input current using the calibration information stored in the instrument memory. If the loop current is too low to power the instrument the indicator will display the error message 'LPLo'.

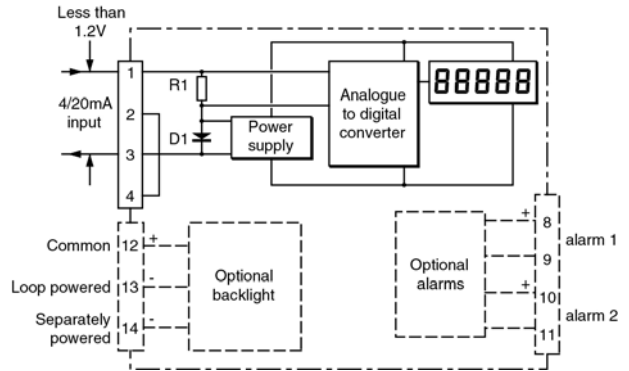

Fig 1 Indicator block diagram

2.1 Controls

The indicators are controlled and calibrated via four front panel push buttons located below the display. In the display mode i.e. when the indicator is displaying a process variable, these push buttons have the following functions:

- P** While this button is pushed the indicator will display the input current in mA, or as a percentage of the instrument span depending upon how the indicator has been configured. When the button is released the normal display in engineering units will return. The function of this push button is modified when optional alarms are fitted to the indicator.
- ▼** While this button is pushed the indicator will display the numerical value and analogue bargraph* the indicator has been calibrated to display with a 4mA^Φ input. When released the normal display in engineering units will return.
- ▲** While this button is pushed the indicator will display the numerical value and analogue bargraph* the indicator has been calibrated to display with a 20mA^Φ input. When released the normal display in engineering units will return.
- E** No function in the display mode unless the tare function is being used.
- P + ▼** Firmware number followed by version.
- P + ▲** Direct access to the alarm setpoints when optional alarms are fitted to the indicator and the 'ACSP' access setpoints in display mode function has been enabled.
- P + E** Access to configuration menu via optional security code.

Note: * BA527E-SS only
^Φ If the indicator has been calibrated using the CAL function, calibration points may not be 4 and 20mA.

3. APPLICATIONS

3.1 Transmitter loops

Both models may be connected in series with any 4/20mA current loop and calibrated to display the measured variable or control signal in engineering units.

Figs 2 illustrate a typical application in which an indicator is connected in series with a 2-wire transmitter.

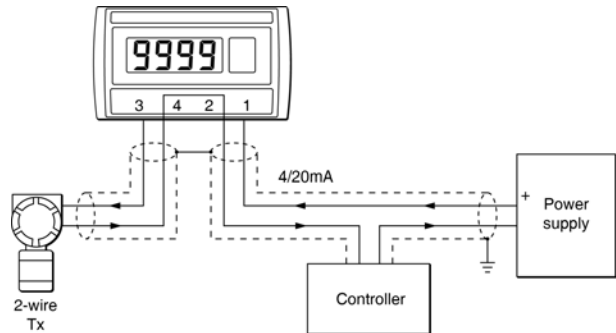

Fig 2 Indicator in a transmitter loop

Considering the example shown in Fig 2, the sum of the maximum voltage drops of all the components in the loop must be less than the minimum power supply voltage.

| | |
|---|-------|
| Minimum operating voltage of 2-wire Tx | 10.0 |
| Maximum voltage drop caused by controller | 5.0 |
| Maximum voltage drop caused by BA507E-SS | 1.3 |
| Maximum voltage caused by cables | 0.4 |
| | 16.7V |

Therefore in this example the power supply must have a minimum output of 16.7V at 20mA.

3.2 Remote indication

Both indicators may be driven from a 4/20mA signal to provide a remote indication. Fig 3 shows a typical application in which the 4/20mA output from a gas analyser is connected to a BA507E-SS loop powered indicator to provide a remote indication of the analyser's output. Again it is necessary to ensure that the voltage capability of the 4/20mA source is greater than the sum of the voltage drops introduced by the indicator and the cable resistance.

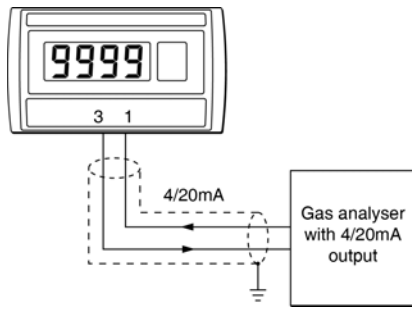

Fig 3 Indicator providing a remote display

4. INSTALLATION

4.1 Location

Both indicators have a robust stainless steel case with a 10mm thick toughened glass window. The case provides 7J and the window 4J front of panel impact protection. The captive silicone gasket, which seals the joint between the instrument and the panel enclosure, ensures IP66 front of panel ingress protection. Both indicators have IP20 rear protection.

Although the front of the indicators have IP66 protection, they should be shielded from continuous direct sunlight and severe weather conditions.

The BA507E-SS and BA527E-SS may be located in any panel providing that the operating temperature is between -40°C and $+70^{\circ}\text{C}$. For most industrial applications the rear of the panel enclosure in which the indicator is mounted should provide additional protection to prevent the ingress of moisture into the rear of the instrument.

4.2 Installation Procedure

- Cut the aperture specified in Fig 4 in the panel enclosure. Ensure that the edges of aperture are de-burred.
- Inspect the indicator's captive gasket and ensure that it is not damaged before inserting the indicator into the panel enclosure aperture.
- If the enclosure panel is less than 1.0mm thick, or is non-metallic, an optional BEKA stainless steel support plate should be slid over the rear of the indicator before the panel clamps are fitted to evenly distribute the clamping force and prevent the enclosure panel being distorted or creeping.
- Slide a panel clamp into the two grooves at each corner of the indicator housing with the M3 stud protruding through the hole at the rear of the clamp. Fit the stainless steel spring washer over the stud and secure with the stainless steel wing nut.
- Evenly tighten the four clamps to secure the instrument. The recommended minimum tightening torque for each wing nut is 22cNm (1.95 lbf in).
- Connect the panel enclosure wiring to the rear terminal blocks. To simplify installation, the terminals are removable so that wiring can be completed before the instrument is installed.

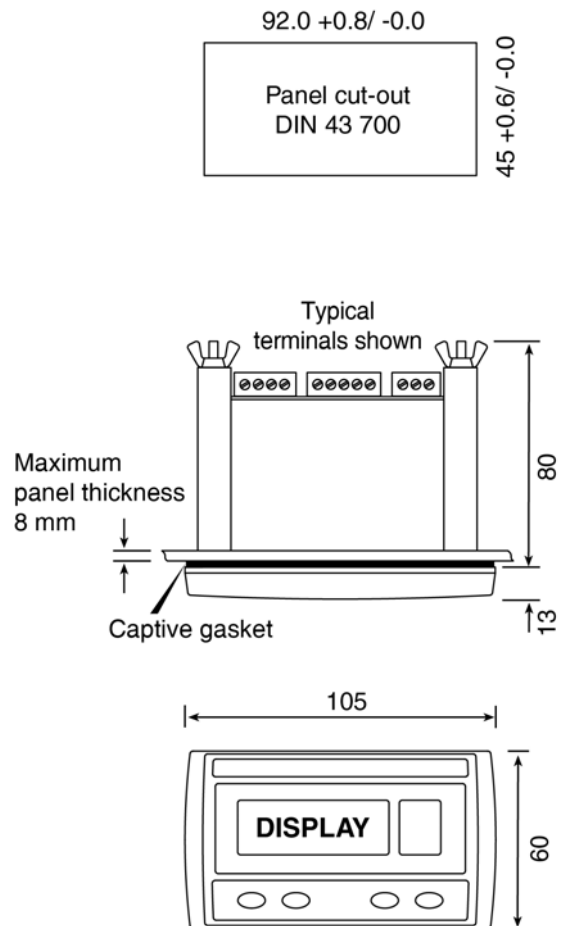
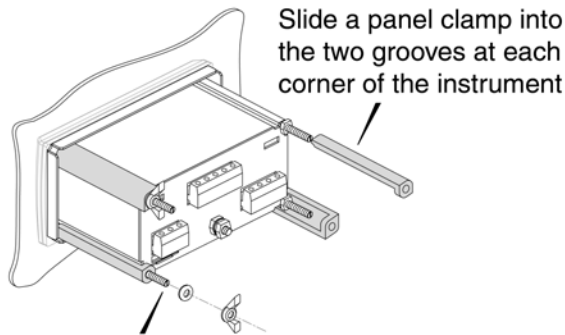
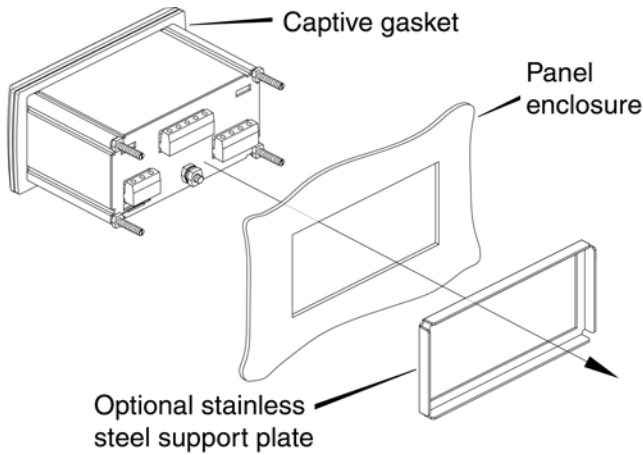

Fig 4 Dimensions

Fig 4 show the overall dimensions of the indicators together with the recommended panel enclosure cut-out dimensions.



Secure each clamp with a stainless steel washer and wing nut, tighten 22cNm (1.95lbf in) min.

Fig 5 Installation procedure

4.3 Indicator earthing

Both indicators have an M4 earth stud on the rear panel which should be electrically connected to the panel enclosure in which the indicator is mounted, or to the plant equipotential conductor.

4.4 EMC

Both instruments comply with the requirements of the European EMC Directive 2004/108/EC. For specified immunity all wiring should be in screened twisted pairs, with the screens earthed in the safe area.

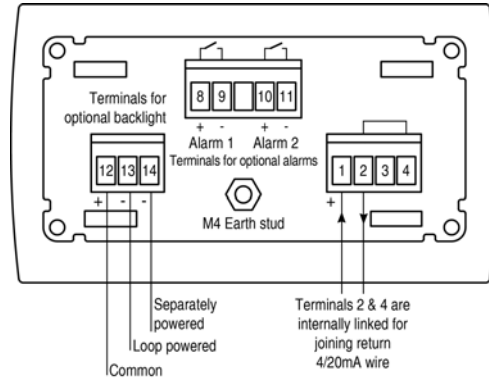

Fig 6 Rear terminals

4.5 Scale card

The indicator's units of measurement are shown on a printed scale card in a window at the right hand side of the display. The scale card is mounted on a flexible strip that is inserted into a slot at the rear of the instrument as shown in Fig 7. Thus the scale card can easily be changed without dismantling the indicator or removing it from the panel enclosure in which it is mounted.

New indicators are supplied with a printed scale card showing the requested units of measurement, if this information is not supplied when the indicator is ordered a blank card will be fitted.

A pack of self-adhesive scale cards printed with common units of measurement is available as an accessory from BEKA associates. Custom printed scale cards can also be supplied.

To change a scale card, unclip the protruding end of the flexible strip by gently pushing it upwards and pulling it out of the rear panel of the indicator. Peel the existing scale card from the flexible strip and replace it with a new printed card, which should be aligned as shown in Fig 7. Do not fit a new scale card on top of an existing card.

Install the new scale card by gently pushing the flexible strip into the slot at the rear of the indicator, when it reaches the internal end-stop secure it by pushing the end of the flexible strip downwards so that the tapered section is held by the rear panel of the indicator.

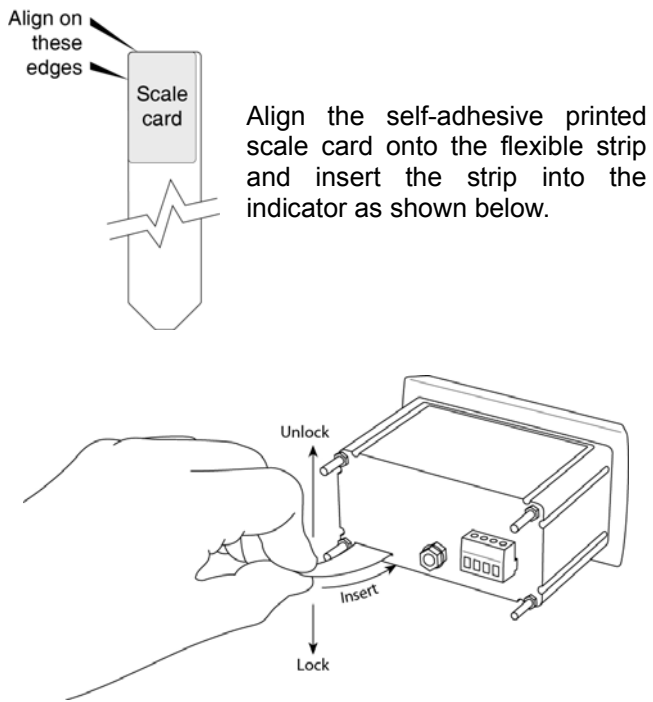

Fig 7 Inserting flexible strip carrying scale card into slot at the rear of indicator.

5. CONFIGURATION AND CALIBRATION

Indicators are configured and calibrated via the four front panel push-buttons. All the configuration functions are contained in an easy to use intuitive menu that is shown diagrammatically in Fig 8.

Each menu function is summarised in section 5.1 and includes a reference to more detailed information. When the indicator is fitted with alarms additional functions are added to the menu which are described in section 8.3

Throughout this manual push buttons are shown as **P**, **E**, **▼** or **▲**, and legends displayed by the indicator are shown within inverted commas e.g. 'CAL' and 'ALr2'.

Access to the configuration menu is obtained by operating the **P** and **E** push buttons simultaneously. If the indicator security code is set to the default 0000 the first parameter 'FunC' will be displayed. If a security code other than the default code 0000 has already been entered, the indicator will display 'CodE'. Pressing the **P** button will clear this prompt allowing each digit of the code to be entered using the **▲** and **▼** push buttons and the **P** button to move control to the next digit. When the correct four digit code has been entered pressing **E** will cause the first parameter 'FunC' to be displayed. If the code is incorrect, or a button is not pressed within twenty seconds, the indicator will automatically return to the display mode.

Once within the configuration menu the required parameter can be reached by scrolling through the menu using the **▲** and **▼** push buttons as shown in Fig 8. When returning to the display mode following recalibration or a change to any function, the indicator will display 'dAtA' followed by 'SAVE' while the new information is stored in non-volatile memory.

All new indicators are supplied calibrated as requested at the time of ordering. If calibration is not requested, indicators will be configured as follows:

| | BA507E-SS | BA527E-SS |
|---------------------------------------|-----------|-----------|
| Access code 'CodE' | 0000 | 0000 |
| Function 'FunC' | Std | Std |
| Display at 4mA 'Zero' | 0.0 | 0.00 |
| Display at 20mA 'SPAn' | 100.0 | 100.00 |
| Resolution 'rESn' | 1 digit | 1 digit |
| Bargraph start 'BarLo' | ---- | 0.00 |
| Bargraph finish 'BarHi' | ---- | 100.00 |
| P button in display mode 'C—P' | % | % |
| Tare 'tArE' | Off | Off |

Default configuration can easily be changed on-site.

5.1 Summary of configuration functions

This section summarises each of the main configuration functions and includes a cross reference to a more detailed description. Fig 8 illustrates the location of each function within the configuration menu. The lineariser and the optional factory fitted alarms are described separately in sections 6 and 8.3 of this manual.

| Display | Summary of function |
|---------|---|
| 'FunC' | <p>Indicator function Defines the relationship between the 4/20mA input current and the indicator display. May be set to:</p> <ul style="list-style-type: none"> 'Std' Standard linear relationship 'root' Square root extraction 'Lin' 16 segment adjustable lineariser – see section 5. <p>See section 5.2</p> |
| 'rESn' | <p>Display resolution Defines the resolution of the least significant display digit. May be set to '1', '2', '5' or '10' digits. See section 5.3</p> |
| 'dP' | <p>Decimal point Positions a dummy decimal point between any of the digits or turns it off. See section 5.4</p> |
| 'CAL' | <p>Calibration of the digital display using an external current source. Enables the zero and span of the indicator to be adjusted using an external current source such as a calibrator. When used with an accurate traceable current source this is the preferred method of calibration. See section 5.5</p> |
| 'SET' | <p>Calibration of display using internal references. Enables the zero and span of the indicator to be adjusted without the need for an accurate input current or disconnection from the 4/20mA loop. See section 5.6</p> |
| 'bAr' | <p>Bargraph format and calibration <i>Only the BA327E-SS has a bargraph</i> The bargraph may be conditioned to start from left, right or centre of the display, or it may be disabled. When optional alarms are fitted it can also display both alarm setpoints and the measured value. The bargraph may be calibrated to start and finish at any value within the indicator's calibrated digital display. See section 5.7</p> |

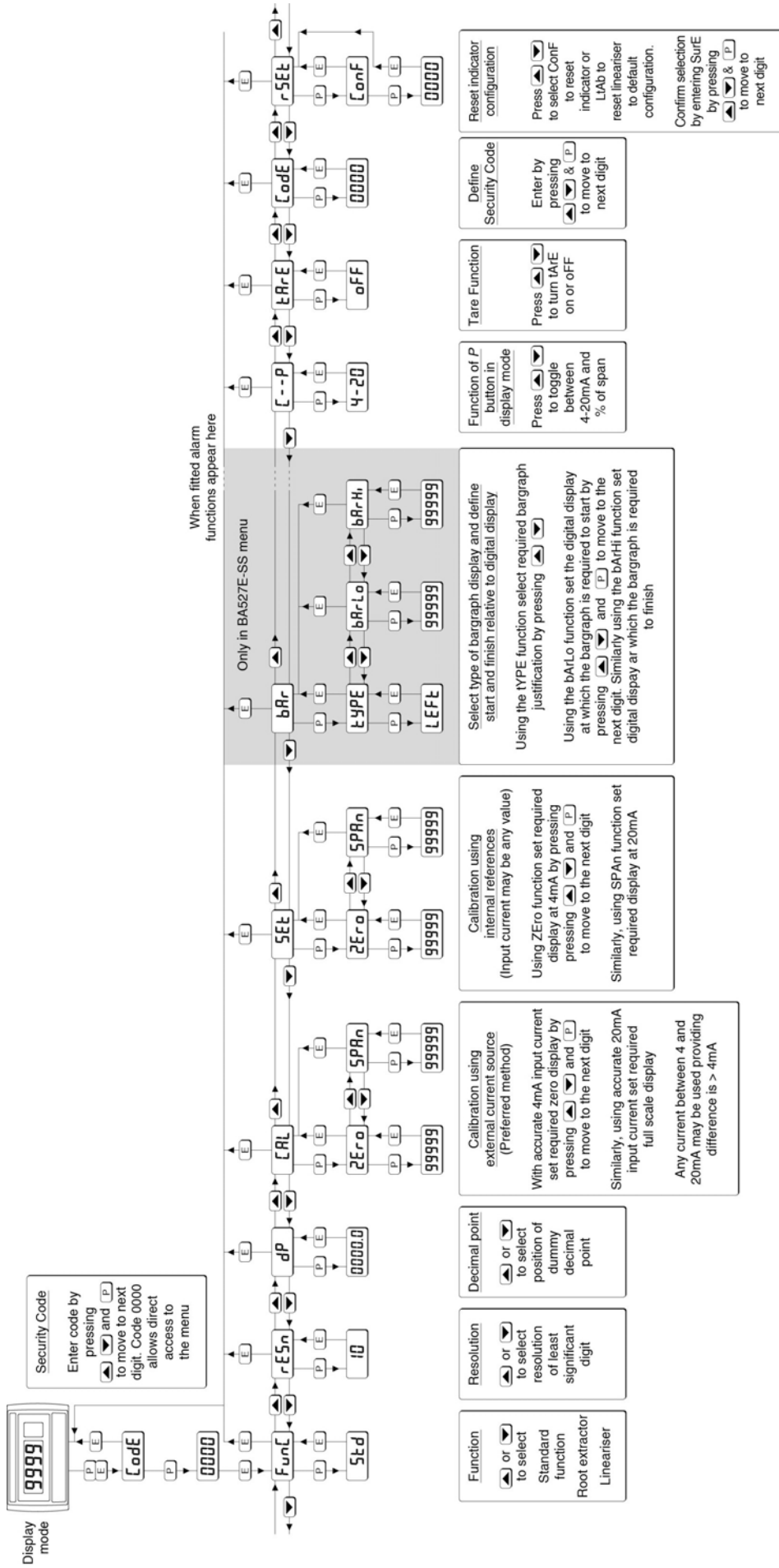

Fig 8 Configuration menu

| Display | Summary of function |
|------------------|---|
| 'C - - P' | <p>Function of P push-button The indicator may be configured to display the input current in milliamps, or the input current as a percentage of the 4/20mA input when the P push button is operated in the display mode. See section 5.8</p> |
| 'tArE' | <p>Tare function When enabled the tare function sets the indicator display to zero when the E push button is operated in the display mode. See section 5.9</p> |
| 'CodE' | <p>Security code Defines a four digit numeric code that must be entered to gain access to the configuration menu. Default code 0000 disables this security function and allows unrestricted access to all conditioning functions. See section 5.10</p> |
| 'rSEt' | <p>Reset Contains two sub-functions, 'ConF' which returns the indicator to the default conditions and 'LtAb' which returns the lineariser to the default conditions. To prevent accidental use both resets must be confirmed by entering '5urE' before they will be executed. See section 5.11</p> |

5.2 Indicator function: 'FunC'

This configuration function defines the relationship between the indicator's 4/20mA input current and the indicator's display. Three alternatives are available:

| | |
|--------|-----------------------------------|
| 'Std' | Standard linear relationship |
| 'root' | Square root extraction |
| 'Lin' | 16 segment adjustable lineariser. |

To reveal the existing indicator function select 'FunC' from the configuration menu and press **P**. If the function is set as required, press **E** to return to the menu, or press the **▲** or **▼** button to change the setting, followed by the **E** button to return to the configuration menu.

'Std' Linear

Provides a linear relationship between the 4/20mA indicator input current and the indicator display.

'root' Square root extraction

Primarily intended to linearise the square law 4/20mA output from differential flowmeters.

For reference, the following table shows the output current from a non-linearised differential flowmeter.

| % of full flow | Current output mA |
|----------------|-------------------|
| 2.5 | 4.01 |
| 10.0 | 4.16 |
| 25.0 | 5.00 |
| 50.0 | 8.00 |
| 75.0 | 13.00 |
| 100.0 | 20.00 |

When the root function is selected the indicator will display flow in linear units.

'Lin' 16 segment adjustable lineariser

Enables non linear variables to be displayed by the indicator in linear engineering units. Use of the lineariser is described in section 6 of this instruction manual.

5.3 Resolution: rESn

This function defines the resolution of the least significant display digit. Decreasing the display resolution can improve the readability of a noisy signal. Select 'rESn' from the menu and press **P** which will reveal the current display resolution. To change the resolution press the **▲** or **▼** button to select 1, 2, 5 or 10 digits, followed by the **E** button to enter the selection and return to the configuration menu.

5.4 Position of the decimal point: 'dP'

A dummy decimal point can be positioned between any of the digits or it may be absent. To position the decimal point select 'dP' from the menu and press **P**. The decimal point can be moved by pressing the **▲** or **▼** push button. If a decimal point is not required it should be positioned beyond the most or least significant digit. When positioned as required press the **E** button to enter the selection and return to the configuration menu.

5.5 Calibration using an external current source: 'CAL'

This function enables the zero and span of the indicator to be adjusted using an external calibrated current source. When used with an accurate traceable current source this is the preferred method of calibration.

Zero is the indicator display with 4mA input
Span is the indicator display with 20mA input

To calibrate the indicator select 'CAL' from the configuration menu and press **P**. The indicator will display 'ZEro' which is a request for a 4mA input current. Adjust the external current calibrator to 4.000mA and again press **P** which will reveal the current zero display. The flashing digit of the indicator display can be changed by pressing the **▲** or **▼** buttons, when set as required pressing **P** will transfer control to the next digit. When all the digits have been adjusted, press **E** to enter the new zero and return to the 'ZEro' prompt.

Pressing the **▲** button will cause the indicator to display 'SPAn' which is a request for a 20mA input current. Adjust the external current calibrator to 20.000mA and again press **P** which will reveal the existing span display. The flashing digit of the indicator display can be changed by pressing the **▲** or **▼** buttons, when set as required pressing **P** will transfer control to the next digit. When all the digits have been adjusted press **E** to enter the new span and return to the 'SPAn' prompt. Finally press **E** again to return to the configuration menu.

Notes:

- The indicator input current must be adjusted to the required value before the zero and span functions are entered by pressing the **P** button.
- Indicators may be calibrated at currents other than 4 and 20mA, within the range 3.8 to 21.0mA providing the difference between the two currents is greater than 4mA. If these conditions are not complied with, the indicator displays 'Fail' and aborts the calibration.
- If the zero current is greater than the span current the instrument will be reverse acting i.e. an increasing input current will cause the display to decrease.

5.6 Calibration using internal reference: 'SEt'

Using the 'SEt' function the indicator can be calibrated without the need for an accurate external current source and without the need to disconnect the indicator from the 4/20mA measuring loop.

The indicator's internal reference is used to simulate a 4mA and 20mA input current, so the actual indicator input current does not have to be known during calibration.

Zero is the display with a simulated 4mA input
Span is the display with a simulated 20mA input

To calibrate the indicator display select 'SEt' from the configuration menu and press **P**. The indicator will display 'ZEro', pressing **P** again will reveal the current display at 4mA. The flashing digit can be adjusted by pressing the **▲** or **▼** buttons, when the flashing digit is correct pressing **P** will transfer control to the next digit. When all the digits have been adjusted, press **E** to return to the 'ZEro' prompt.

To adjust the display at 20mA, press the **▲** button which will cause the indicator to display 'SPAn', pressing **P** will then reveal the indicator's existing display at 20mA. The flashing digit can be adjusted by pressing the **▲** or **▼** buttons, when the flashing digit is correct pressing **P** will transfer control to the next digit. When all the digits have been adjusted press **E** to return to the 'SPAn' prompt followed by **E** to return to the 'SEt' prompt in the configuration menu.

5.7 Bargraph format and calibration: 'bAr'

Only the BA527E-SS has a bargraph

In addition to a five digit numerical display the BA527E-SS has a 31 segment analogue bargraph which may be configured to start and finish anywhere within the indicators numerical display range.

To configure the bargraph select 'bAr' from the configuration menu and press **P**. The indicator will display 'tYPE', pressing **P** again will reveal the existing bargraph justification which can be changed to one of the following four or five options using the **▲** or **▼** button:

| | Bargraph starts from |
|---------|---------------------------------------|
| 'LEFT' | Left end of display |
| 'CEnt' | Centre of display |
| 'riGHT' | Right end of display |
| 'AlrSP' | Only with alarms – see section 9.3.14 |
| 'oFF' | Bargraph disabled |

When set as required press **E** to return to the 'tYPE' sub-function prompt.

The indicator's digital display at which the bargraph starts is defined by the 'bArLo' sub-function which is selected by pressing the ▲ button followed by the **P** button which will reveal the current indicator display at which the bargraph starts. The flashing digit can be adjusted by pressing the ▲ or ▼ buttons, when set as required pressing **P** will transfer control to the next digit. When all the digits have been adjusted, press **E** to return to the 'bArLo' prompt from which 'bArHi' which defines the finishing point of the bargraph can be selected by pressing the ▲ button. 'bArHi' is adjusted in the same way as 'bArLo'. When set as required, pressing **E** twice will return the display to the 'bAr' prompt in the configuration menu.

Note: 'bArLo' must be set lower than 'bArHi', incorrect setting is indicated by the bargraph scale flashing with a single bargraph segment activated.

5.8 Function of the **P** push button: 'C - - P'

When the indicator is in the display mode, operating the **P** push button will display the input current in milliamps, or the displayed value as a percentage of the difference between the displayed values at 4mA and 20mA inputs.

To check or change the function of the **P** push button select 'C - - P' from the configuration menu and press **P** to reveal the current setting. Pressing the ▲ or ▼ button will toggle the setting between '4-20' the current display in milliamps and 'PC' the percentage display. When set as required press **E** to return to the 'C - - P' prompt in the configuration menu.

5.9 Tare function: 'tArE'

The tare function is primarily intended for use with weighing system. When the indicator is in the display mode and the tare function is activated, pressing the **E** button for more than three seconds will zero the indicator's digital display and activate the tare annunciator. On the BA527E-SS the bargraph remains linked to the digital display when the tare function is activated. Subsequent operation of the **E** push button for less than 3 seconds will return the indicator to the gross display and deactivate the tare annunciator.

To check or change the tare function select 'tARE' from the configuration menu and press **P** to reveal the current setting. Pressing the ▲ or ▼ button will toggle the setting between 'on' and 'oFF'. When set as required press **E** to return to the 'tARE' prompt in the configuration menu.

5.10 Security code: 'CodE'

Access to the instrument configuration menu may be protected by a four digit security code which must be entered to gain access. New instruments are configured with the default security code 0000 which

allows unrestricted access to all configuration functions.

To enter a new security code select 'CodE' from the configuration menu and press **P** which will cause the indicator to display the existing security code with one digit flashing. The flashing digit can be adjusted using the ▲ and ▼ push-buttons, when set as required operating the **P** button will transfer control to the next digit. When all the digits have been adjusted press **E** to return to the 'CodE' prompt. The revised security code will be activated when the indicator is returned to the display mode. Please contact BEKA associates sales department if the security code is lost.

5.11 Reset to factory defaults: 'rSEt'

This function enables the indicator and the lineariser to be quickly returned to the factory default configurations shown in sections 5 and 6.

To reset the indicator or lineariser select 'rSEt' from the configuration menu and press **P**, the indicator will display one of the reset options 'ConF' or 'LTab'.

| | |
|--------|-----------------------------------|
| 'ConF' | Resets the indicator to defaults |
| 'LTab' | Resets the lineariser to defaults |

Using the ▲ or ▼ push button select the required sub-function and press **P**. To prevent accidental resetting the request must be confirmed by entering '5urE'. Using the ▲ button set the first flashing digit to '5' and press **P** to transfer control to the second digit which should be set to 'u'. When '5urE' has been entered pressing the **E** button will reset the selected configuration menus and return the display to the 'rSEt' function in the configuration menu.

5.12 Under and over-range

If the numerical display range of the indicator is exceeded, all the decimal points will flash as shown below:

| | BA507E-SS | BA527E-SS |
|------------|-----------|------------|
| Underrange | -9.9.9.9 | -9.9.9.9.9 |
| Overrange | 9.9.9.9 | 9.9.9.9.9 |

Although not guaranteed, most indicators will continue to function normally with an input current between 1.8mA and 4mA, at lower currents the instrument will display 'LPLo' before it stops functioning.

Under or overrange of the BA527E-SS bargraph is indicated by an activated arrow at the appropriate end of the bargraph and a flashing bargraph scale.

6. LINEARISER

A sixteen segment, seventeen break-point (0 to 16) lineariser may be selected in the 'FunC' section of the configuration menu. The position of each break-point is fully adjustable so that the slope of the straight line between break-points can be set to compensate for input non-linearity, thus allowing the indicator to display a non-linear process variables in linear engineering units. Each break-point must occur at a current greater than the preceding break-point and less than the following break-point, in the range 3.8 to 21.0mA. If this requirement is not observed when configuring the lineariser the indicator will display 'Fail' and the configuration adjustment which produced the error message will be ignored. Fig 9 shows a typical linearised indicator characteristic.

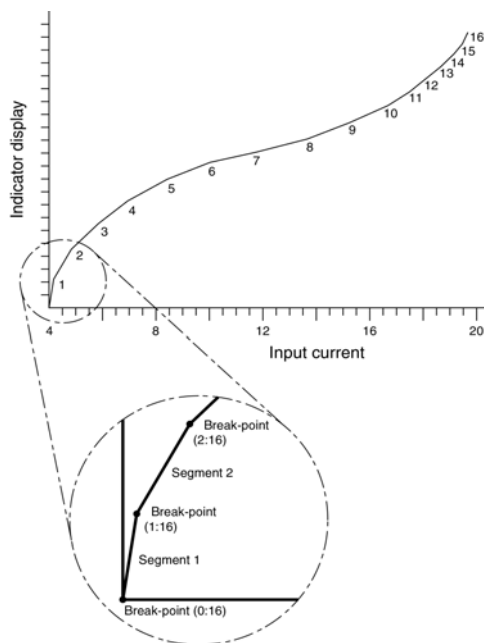

Fig 9 shows a typical linearising characteristic

Selecting 'Lin' in the 'FunC' section of the configuration menu activates the lineariser, this does not change the configuration menu shown in Fig 8, but the 'CAL' and 'SET' functions are extended as shown in Fig 10. As with a linear indicator, calibration of the lineariser may be performed with an external current source using the 'CAL' function, or with the internal reference using the 'SET' function.

The lineariser calibration is retained irrespective of how the indicator function 'FunC' is subsequently changed. It is therefore possible to select and deselect the lineariser without having to reconfigure it each time.

The lineariser calibration may be reset to the factory default settings without changing the indicator configure using the 'Ltab' function described in section 5.11.

6.1 Lineariser calibration using an external current source.

This method allows direct calibration of the lineariser with an external current source and is the preferred method when traceability is required. If the exact system non-linearity is unknown, this method also allows direct calibration from the variable to be displayed. e.g. the output from a level sensor in an irregular tank may be displayed in linear volumetric units by filling the tank with known incremental volumes and calibrating the indicator to display the sum of the increments at each break-point.

The number of break-point required should first be entered using the 'Add' and 'dEL' functions. In both these sub-functions the indicator initially displays the current break-point and the total number of break-points being used as shown below.

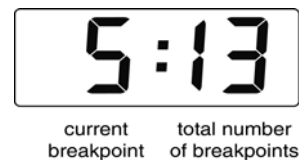

Display

Description of function

'Add'

Add a break-point

Adds a new break-point before the displayed break-point. The calibration of existing break-points is not changed, but the identification number of all subsequent break-points is increased by one.

'dEL'

Remove a break-point

Removes the displayed break-point and joins the preceding break-point to the following break-point with a straight line. The identification number of all subsequent break-points is decreased by one.

To add a break-point use the ▲ or ▼ button to select 'CAL' from the configuration menu and press **P** which will result in the 'Add' sub-function prompt being displayed. To enter the sub-function press **P** which will reveal the current break-point and the total number of break-points which have already been entered. When adding a break-point the insertion position can be selected using the ▲ and ▼ push buttons followed by **P** push button to insert the additional break-point. In previously uncalibrated linearisers each new break-point should be added in front of the highest existing break-point, if this sequence is not followed a 'Fail' message will occur in the 'Pt5' function. See example in section 6.1.1.

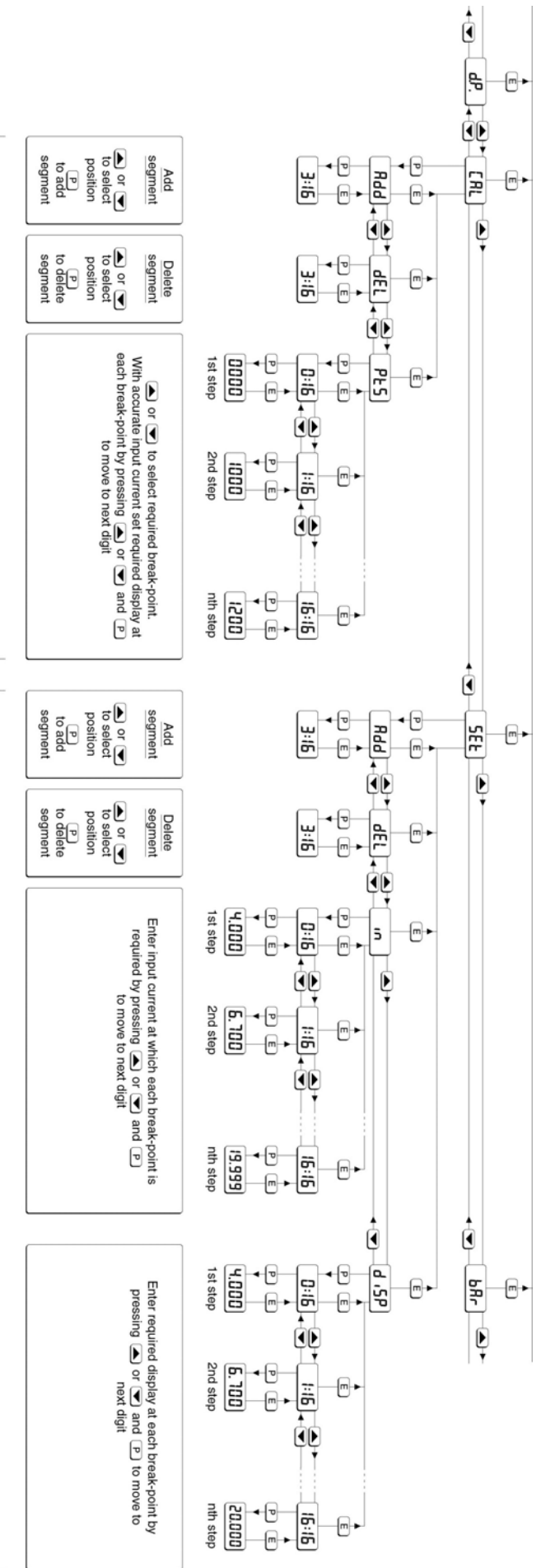

Each break-point must occur at an input current greater than the proceeding break-point and less than the following break-point, in the range 3.8 to 21.0 mA

Fig 10 Extension of CAL and Set functions for lineariser configuration

The delete break-point sub-function 'dEL' operates in exactly the same way as the 'Add' sub-function described above. Once within the 'dEL' sub-function each time the **P** button is pressed a break-point is removed. When deleting a break-point from a calibrated indicator, the break-point to be deleted can be selected using the **▲** and **▼** push buttons. The minimum number of break-point is 2, break-points '0:1' and '1:1'.

When the required number of linearising break-points has been entered, return to the linearisation sub-menu by pressing **E**. The indicator will display the 'Add' or 'dEL' prompt depending upon the last function used. Using the 'Pts' sub-function the input current at which each break-point occurs and the corresponding indicator display may now be defined.

Using the **▲** or **▼** button select the 'Pts' function in the sub-menu and press **P** to enter the function which will display the first break-point '0:n', where n is the total number of linearising break-points entered – see Fig 9. The selected linearising break-point can be changed using the **▲** and **▼** buttons. When the required linearising break-point has been selected set the indicator input current to the exact value at which the break-point is required and press **P***. Using the **▲** and **▼** buttons and the **P** button to move between digits, enter the required indicator display at this break-point. When set as required, press the **E** push button to enter the required indicator display and return to the sub-menu from which the next break-point can be selected.

When all the break-points have been calibrated pressing **E** twice will return the indicator to the 'CAL' function in the configuration menu.

Note: * The indicator input current must be adjusted to the required value before the **P** button is operated to enter the required indicator display.

Error message

If during calibration the indicator displays a 'FAiL' error message the current at which the selected break-point is being set is not above the preceding break-point or is not below the following break-point.

6.1.1 Example

Adding break-points to a new indicator

When adding break-points to a new indicator, or to a lineariser following resetting to the factory defaults using the 'LtAb' function described in section 5.11, each additional break-point should be added before the highest existing breakpoint. The first additional break-point should be added before the default break-point '1:1' which will result in a display of '1:2'. If more new break-points are required, using the **▲** button select the new highest break-point '2:2' and

add the second additional break-point by operating the **P** push button which will result in a display of '2:3'. Repeat the sequence until the required number of break-points has been entered.

The input current and at which each break-point occurs and the corresponding indicator display may now be entered as described above.

6.2 Lineariser calibration using the internal reference.

The 'SEt' function enables the lineariser to be calibrated without the need for an accurate external current source. Throughout the calibration the indicator input current may be any value between 4 and 20mA.

The 'SEt' functions contains four sub-functions.

| Display | Description of function |
|----------------|--|
| 'Add' | Add a break-point Adds a new break-point before the displayed break-point. The calibration of existing break-points is not changed, but the identification number of all subsequent break-point is increased by one. |
| 'dEL' | Remove a break-point Removes the displayed break-point and joins the preceding segment to the following segment with a straight line. The identification number of all subsequent break-points is decreased by one. |
| 'in' | Defines the current at which break-point occurs. Enables the required current at each break-point to be defined without having to input an accurate input current to the indicator. |
| 'diSP' | Defines indicator display at break-point. Enables the indicator display at each break-point to be defined. |

The number of break-point required should first be entered using the 'Add' and 'dEL' sub-functions. In both these sub-functions the indicator initially displays the current break-point and the total number of break-point being used as shown below.

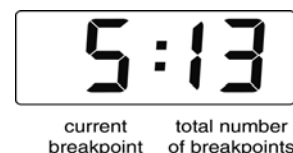

To add a break-point using the ▲ or ▼ button select 'SEt' from the configuration menu and press **P** which will result in the 'Add' sub-function prompt being displayed. To enter the sub-function press **P** which will reveal the current break-point and the total number of break-points which have already been entered. When adding a break-point the insertion position can be selected using the ▲ and ▼ push buttons followed by **P** push button to insert the additional break-point. In previously uncalibrated linearisers each new break-point should be added in front of the highest existing break-point, if this sequence is not followed a 'Fail' message will occur when the breakpoints are calibrated. See example in section 6.2.1.

The delete break-point, sub-function 'dEL' operates in exactly the same way as the 'Add' sub-function described above. Once within the 'dEL' function each time the **P** button is pressed a break-point is removed. When deleting a break-point from a calibrated indicator, the break-point to be deleted can be selected using the ▲ and ▼ push buttons. The minimum number of break-point is 2, break-points '0:1' and '1:1'.

When the required number of linearising break-point has been entered, return to the linearisation sub-menu by pressing **E**. The indicator will display the 'Add' or 'dEL' prompt depending upon the last sub-function used. The indicator input current and corresponding indicator display at each break-point can now be entered using the 'in' and 'diSP' sub-functions.

Using the ▲ or ▼ button select 'in' from the sub-menu and press **P** which will reveal the starting point for the first segment '0:n', where n is the total number of break-point entered. Press **P** and use the ▲ and ▼ buttons and the **P** button to move between digits, to enter the input current in milliamps at which the first break-point is required, usually 4.000mA. When set as required, press **E** to return to the '0:n' prompt from which the next break-point can be selected using the ▲ and ▼ buttons. When the required break-point has been selected press **P** and enter the indicator input current at which this break-point is required using the ▲ and ▼ buttons and the **P** button to move between digits,. Repeat this procedure until the indicator input current at all the break-points has been defined and then return to the 'in' sub-function by pressing the **E** button.

The corresponding indicator display at each of the break-points can now be defined using the 'diSP' sub-function Using the ▲ and ▼ buttons select the 'diSP' sub-function and press **P** which will reveal the starting point for the first break-point '0:n', where n is the total number of break-points entered. Press **P** and use the ▲ and ▼ buttons and the **P** button to move between digits, to enter the required indicator display at the first break-point. When set as required, press **E** to return to the '0:n' prompt from which the

next break-point can be selected using the ▲ or ▼ buttons. When the required break-point has been selected press **P** and set the required indicator display at this break-point.

Repeat this procedure until the indicator display at all the break-points has been defined and then return to the 'SEt' function in the configuration menu by pressing the **E** button twice.

Error message

If during calibration the indicator displays a 'FAiL' error message the current at which the selected break-point is being set is not above the proceeding break-point or is not below the following break-point.

6.2.1 Example

Adding break-points to a new indicator

When adding break-points to a new indicator, or to a lineariser following resetting to the factory defaults using the 'LTab' function described in section 6.11, each additional break-point should be added before the highest existing breakpoint. The first additional break-point should be added before the default break-point '1:1' which will result in a display of '1:2'. If more new break-points are required, using the ▲ button select the new highest break-point '2:2' and add the second additional break-point by operating the **P** push button which will result in a display of '2:3'. Repeat the sequence until the required number of break-points has been entered.

6.3 Under and over-range

The lineariser does not change the under and over-range indication described in section 6.12. At input currents below that specified for the first break-point '0:n', the indicator will continue to use the specified slope of the first segment.

At input currents above that specified for the last break-point 'n:n', the indicator will continue to use the slope specified for the last lineariser segment.

6.4 Lineariser default configuration

When the lineariser is reset to the factory defaults using the 'LTab' function described in section 5.11, the defaults conditions are:

| | Indicator display | | |
|--------------------------|-------------------|-----------|--------|
| | BA507E-SS | BA527E-SS | |
| First break-point '0:1' | 4mA | 0.0 | 0.00 |
| Second break-point '1:1' | 20mA | 100.0 | 100.00 |

7. MAINTENANCE

7.1 Fault finding during commissioning

If an indicator fails to function during commissioning the following procedure should be followed:

| Symptom | Cause | Solution |
|--|--|---|
| No display | Incorrect wiring | Check wiring There should be 0.6 to 1.2V between terminals 1 & 3 with terminal 1 positive. With an optional loop powered backlight, there should be 3.4 to 5V between terminals 3 & 12 with terminal 12 positive. |
| No display 0V between terminals 1 & 3. | Incorrect wiring or no power supply. | Check supply voltage and voltage drop caused by all the instruments in the loop. |
| All decimal points flashing. | Underrange if -ve sign displayed or overrange. | Recalibrate the numerical display. |
| Unstable display | 4/20mA input is noisy. | Reduce ripple on 4/20mA power supply and/or decrease indicator resolution. |
| Unable to enter configuration menu. | Incorrect security code entered. | Enter correct security code, or contact BEKA if the code has been lost. |

7.2 Fault finding after commissioning

ENSURE PLANT SAFETY BEFORE STARTING MAINTENANCE

If an indicator fails after it has been functioning correctly follow the procedure shown in section 7.1. If this does not reveal the cause of the fault, it is recommended that the instrument is replaced. This can be done without disconnecting power, but while the indicator is disconnected the 4/20mA loop will be open circuit.

7.3 Servicing

All BA507E-SS and BA527E-SS loop powered indicators are interchangeable if the required optional backlight and alarms are fitted. A single spare instrument may quickly be recalibrated to replace any instrument that is damaged or fails. No attempt should be made to repair instruments at component level.

We recommend that faulty instruments are returned to BEKA associates or to your local BEKA agent for repair.

7.4 Routine maintenance

The mechanical and electrical condition of the instrument should be regularly checked. Initially annual inspections are recommended, but the inspection frequency should be adjusted to suit the environmental conditions.

7.5 Guarantee

Indicators which fail within the guarantee period should be returned to BEKA associates or your local agent. It is helpful if a brief description of the fault symptoms is provided.

7.6 Customer comments

BEKA associates is always pleased to receive comments from customers about our products and services. All communications are acknowledged and whenever possible, suggestions are implemented.

8. ACCESSORIES

8.1 Scale card

Both models have a window on the right hand side of the display through which to view a scale card showing the units of measurement such as °C, mBar, RPM. New indicators are fitted with a scale card showing the units of measurement specified when the indicator was ordered, if the units are not specified a blank scale card will be fitted. A pack of scale cards pre-printed with common units of measurement is available as an accessory. These can easily be fitted on-site to the indicator without opening the indicator enclosure or removing it from the panel, See section 4.5 of this instruction manual.

Custom scale cards for applications requiring less common units of measurement are also available.

8.2 Tag information

New indicators are supplied with tag or application information laser etched onto the rear panel adjacent to the terminals, legend as specified when the indicator was ordered. This tag information is not visible from the front of the instrument after installation.

8.3 Alarms

CAUTION

These alarms outputs should not be used for critical safety applications such as an emergency shut down system.

Both models can be supplied with factory fitted dual solid state, single pole alarm outputs. Each alarm output may be independently conditioned as a high or low alarm with a normally open or normally closed output in the non-alarm condition.

When the 4/20mA current powering the indicator is removed both alarm outputs will open irrespective of configuration. The open circuit condition should therefore be chosen as the alarm condition when designing an alarm system. Fig 11 illustrates the conditions available and shows which are fail safe.

When an alarm occurs an alarm annunciator on the indicator front panel is activated and if required the numerical display can alternate between the measured value and the alarm channel identification 'ALr1' or 'ALr2'.

CAUTION

The alarms are activated by the indicator's numerical display. Use of the Tare Function 'tArE' will change the numerical display, the alarms will continue to function at the original displayed value, but this will correspond to a different input current.

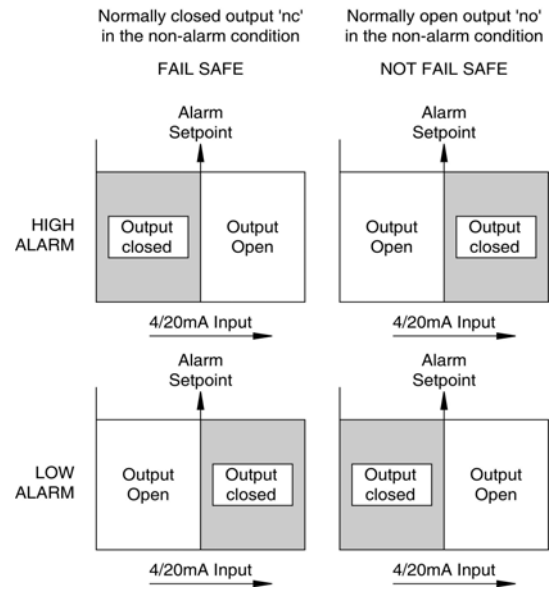

Fig 11 Alarm outputs

Configurable functions for each alarm include adjustable setpoint, hysteresis, alarm delay and alarm accept.

8.3.1 Solid state output

Each alarm has a galvanically isolated single pole solid state switch output which as shown in Fig 12. The output is polarised and current will only flow in one direction.

- Ron = less than 5Ω + 0.7V
- Roff = greater than 1MΩ

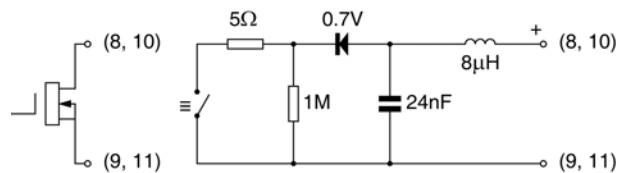

Fig 12 Equivalent circuit of each alarm output

The solid state output of each alarm may be used to switch any dc circuit with parameters equal to or less than:

- V = 30V
- I = 200mA

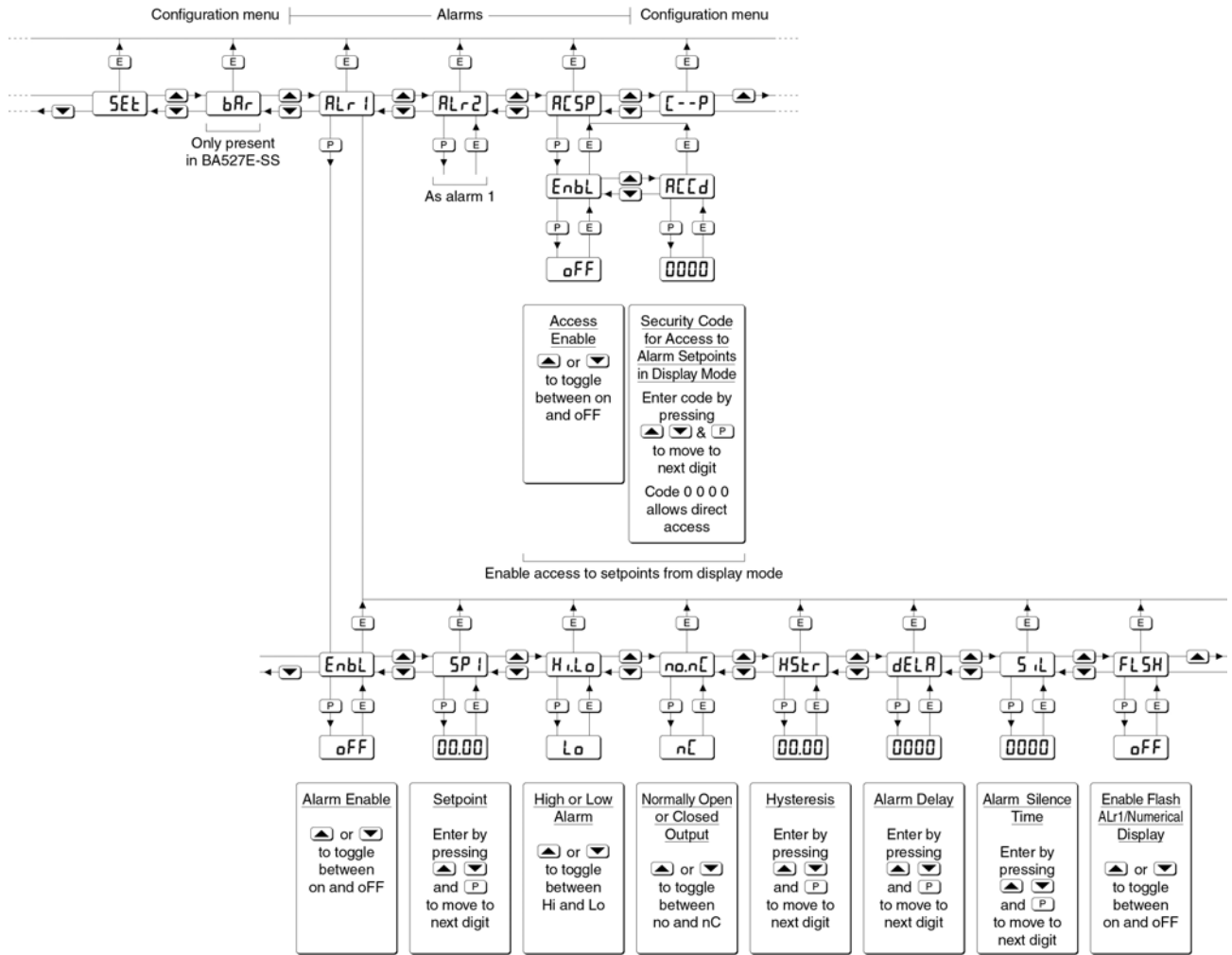

Fig 13 Alarm Functions in Configuration Menu

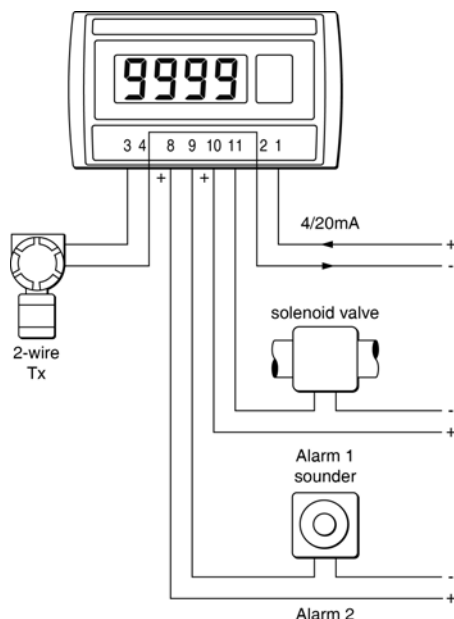

Fig 14 Typical alarm application
(Shown without recommended screened cables)

8.3.2 Configuration and adjustment

When optional alarms are fitted to a loop powered indicator the configuration menu is extended as shown in Fig 13. The additional functions appear between the 'SEt' and the 'C- - P' functions for the BA507E-SS and and between 'bAr' and 'C- -P' for the BA527E-SS indicators. For simplicity, Fig 13 only shows the additional functions for alarm 1, but alarm 2 has identical functions.

The following table summaries each of the alarm configuration functions and includes a cross reference to more detailed information. Again only the functions on alarm 1 are listed, but alarm 2 has identical facilities.

Summary of alarm configuration functions

| Display | Description of function |
|---------|--|
| 'EnbL' | Alarm enable Enables or disables the alarm without changing the alarm parameters. See section 8.3.3 |
| 'SP1' | Alarm setpoint 1 Adjusts the alarm setpoint. The alarm is activated when the indicator display equals the setpoint. See section 8.3.4 |
| 'Hi.Lo' | Alarm function Defines the alarm function as High or Low. See section 8.3.5 |
| 'no.nC' | Normally open or normally closed output Sets the alarm output open or closed in the non-alarm condition. See section 8.3.6 |
| 'HStr' | Hysteresis Adjusts the alarm hysteresis. See section 8.3.7 |
| 'dELA' | Alarm delay time Introduces adjustable delay between the display equalling the setpoint and the alarm output being activated. See section 8.3.8 |
| 'SiL' | Alarm silence time Defines the time that the alarm output remains in the non-alarm condition following acceptance of an alarm. See section 8.3.9 |
| 'FLSH' | Flash display when alarm occurs When enabled, alternates the numerical display between process value and alarm reference, 'ALr1' or 'ALr2', when an alarm output is activated. See section 8.3.10 |
| 'ACSP' | Access setpoint Sub-menu which enables direct access to the alarm setpoints from the indicator display mode, and defines a separate security code. See section 8.3.11 |

8.3.3 Alarm enable: 'EnbL'

This function allows each alarm to be enabled or disabled without altering any of the alarm parameters. To enable or disable the alarm select 'EnbL' from the alarm menu and press **P** which will reveal the current setting 'on' or 'oFF'. The function can be changed by pressing the ▲ or ▼ button followed by the **E** button to return to the alarm menu.

8.3.4 Setpoint adjustment: 'SP1' and 'SP2'

The setpoint of each alarm may be positioned anywhere in the numerical display of the indicator providing that this corresponds to an input current between 3.8 and 20.2mA. e.g. If the indicator has been calibrated to display 0 with 4mA input and 10000 with 20mA input, the two alarm setpoints may be positioned anywhere between -125 and 10125.

To adjust the setpoint select 'SP1' or 'SP2' from the alarm configuration menu and press **P** which will reveal the existing alarm setpoint. The flashing digit of the setpoint can be adjusted using the ▲ and ▼ push buttons, and the **P** button to move control to the next digit. When the required setpoint has been entered press **E** to return to the alarm configuration menu.

The alarm setpoints may also be adjusted when the indicator is in the display mode, see section 8.3.12.

8.3.5 Alarm function: 'Hi.Lo'

Each alarm can be independently conditioned as a high alarm or as a low alarm. To check or change the alarm function select 'Hi.Lo' from the alarm menu and press **P** to reveal the current setting. The function can be changed by pressing the ▲ or ▼ button followed by the **E** button to return to the alarm menu.

8.3.6 Alarm output status: 'no.nC'

Configures the solid state alarm output to be open 'no' or to be closed 'nC' in the non-alarm condition. When deciding which is required, care should be taken to ensure that the alarm output is fail safe as illustrated in Fig 11.

'no' Alarm output open in non-alarm condition

'nC' Alarm output closed in non-alarm condition

CAUTION

When the 4/20mA supply is removed from the loop powered indicator, both alarm outputs will open irrespective of conditioning. Therefore for fail safe operation both alarm outputs should be conditioned to be open in the alarm condition 'nC'.

To check or change the alarm output status, select 'no.nC' from the alarm configuration menu and press **P** to reveal the setting. The function may be changed by pressing the ▲ or ▼ button followed by the **E** button to return to the alarm configuration menu.

8.3.7 Hysteresis: HStr

Hysteresis is shown in the units that the indicator has been calibrated to display.

To adjust the hysteresis select 'HStr' from the alarm menu and press **P** which will reveal the existing figure. The flashing digit can be adjusted using the ▲ and ▼ push buttons, and the **P** button will move control to the next digit. When the required hysteresis has been entered press **E** to return to the alarm configuration menu.

e.g. An indicator calibrated to display 0 to 10000, with a high alarm set at 9000 and hysteresis of 200 will perform as follows:

The high alarm will be activated when increasing indicator display equals 9000, but will not reset until the indicator display falls below 8800.

8.3.8 Alarm delay: dELA

This function delays activation of the alarm output for an adjustable time following the alarm condition occurring. The delay can be set in 1 second increments between 0 and 3600 seconds. If a delay is not required zero should be entered. To adjust the delay select 'dELA' from the alarm configuration menu and press **P** which will reveal the existing delay. The flashing digit of the delay can be adjusted using the ▲ and ▼ push buttons, and the **P** button to move control to the other digits. When the required delay has been entered press **E** to return to the alarm menu.

e.g. An indicator with a high alarm set at 9000 and an alarm delay of 30 seconds will perform as follows:

The alarm annunciator will start to flash when an increasing indicator display equals 9000, but the alarm output will not be activated until the alarm condition has existed continuously for 30 seconds. When the alarm output is activated, the alarm annunciator will stop flashing and become permanently activated.

If the 'FLSH' function, which flashes the indicator display when an alarm occurs, has been enabled, it will not start to function until the alarm output is activated.

See section 8.3.10

8.3.9 Alarm silence time: SiL

This function is primarily intended for use in small installations where the alarm output directly operates an alarm annunciator such as a sounder or beacon. When the alarm silence time, which is adjustable between 0 and 3600 seconds in 1 second increments, is set to any figure other than zero, the **P** push button becomes an alarm accept button. After an alarm has occurred, operating the **P** button will cause the alarm output to revert to the non-alarm condition for the programmed alarm silence time. If the alarm condition still exists at the end of the silence time, the alarm output will be reactivated. During the silence time the indicator alarm annunciator will flash until the silence time expires or the alarm is cleared.

If the 'FLSH' function, which flashes the indicator display when an alarm occurs has been enabled, it will only function when the alarm output is activated, not during the silence time. See section 8.3.10

To adjust the alarm silence time select 'SiL' from the alarm configuration menu and press **P** which will reveal the existing silence time. The flashing digit of the silence time can be adjusted using the **▲** and **▼** push buttons, and the **P** button to move control to the other digits. When the required silence time has been entered press **E** to return to the alarm menu.

8.3.10 Flash display when alarm occurs 'FLSH'

In addition to the two alarm annunciators on the top left hand corner of the indicator display which show the status of both alarms, this function provides an even more conspicuous indication that an alarm condition has occurred.

When enabled, the function alternates the indicator display between the numerical value and the alarm reference, 'ALr1' or 'ALr2', when the alarm output is activated. If both alarm outputs are activated, the alarm references are displayed in sequence.

To enable or disable the function select 'FLSH' from the alarm menu and press **P** which will reveal the current setting 'on' or 'oFF'. The function can be changed by pressing the **▲** or **▼** button followed by the **E** button to return to the alarm menu.

8.3.11 Access setpoint in display mode: ACSP

This function enables a separate menu providing access to the alarm setpoints from the display mode by simultaneously operating the **P** and **▲** push buttons. An operator can therefore adjust the alarm setpoints without having access to the indicator configuration menu. Protection against accidental adjustment of the setpoints when the indicator is in the display mode is provided by a separate security code.

This direct setpoint access menu is enabled and the separate security code entered from the 'ACSP'

function in the alarm configuration menu as shown in Fig 13. To change the menu parameters select 'ACSP' from the configuration menu and press **P** which will display the enable prompt 'EnbL'. Press **P** again to reveal if the direct access menu is 'on' or 'oFF'. The **▲** or **▼** button will toggle the display between the two conditions.

If 'oFF' is selected, the operator will not have access to the setpoints from the display mode. Return to the 'ACSP' prompt in the main menu by pressing **E** twice.

If 'on' is selected, the operator will have direct access to the alarm setpoints from the display mode via a separate optional security code. To define this four digit security code press **P** to return to the 'EnbL' prompt followed by the **▲** or **▼** button to select the access code prompt 'ACCd'. Pressing **P** will reveal the current security code. Each digit of the code may be changed by operating the **▲** and **▼** push buttons, and the **P** button to move control to the next digit. When the required code has been entered, press **E** twice to return to the 'ACSP' prompt in the configuration menu.

Default code 0000 will disable the security code allowing direct access to the setpoints in the display mode by pressing the **P** and **▲** buttons simultaneously. Unless otherwise requested new instruments with alarms are supplied with this function disabled and the security code set to 0000.

8.3.12 Adjusting alarm setpoints from the display mode

Access to the alarm setpoints from the indicator display mode is obtained by operating the **P** and **▲** push buttons simultaneously as shown in Fig 15. If the setpoints are not protected by a security code the alarm setpoint prompt 'SP1' will be displayed. If the setpoints are protected by a security code, 'Code' will be displayed first. Pressing **P** again will enable the alarm security code to be entered digit by digit using the **▲** and **▼** buttons to change the flashing digit, and the **P** push button to move control to the next digit. If the correct code is entered pressing **E** will cause alarm setpoint prompt 'SP1' to be displayed. Pressing the **▲** or **▼** button will toggle the display between the two alarm setpoint prompts 'SP1' and 'SP2'.

If an incorrect security code is entered, or a button is not pressed within twenty seconds, the indicator will automatically return to the display mode.

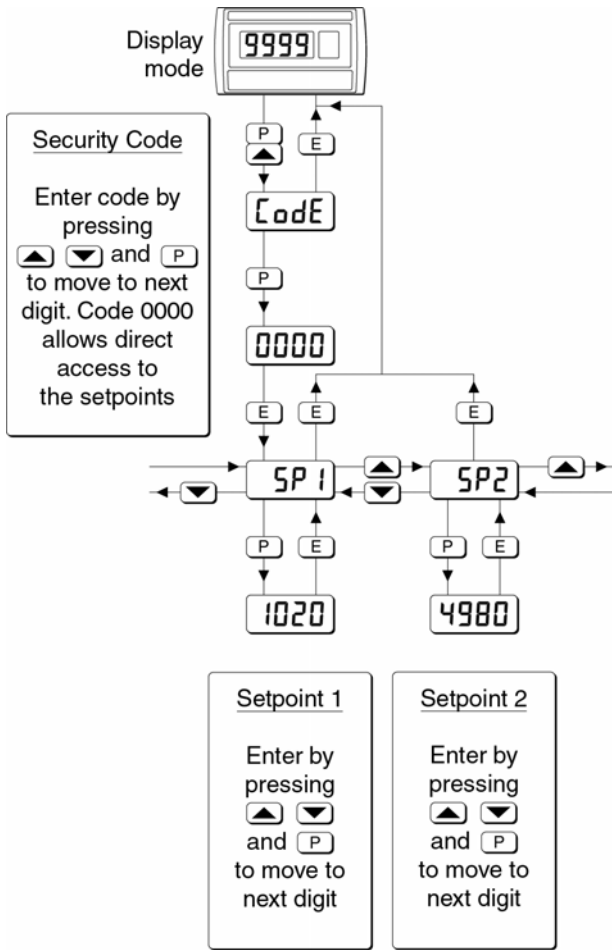

Fig 15 Setpoint adjustment from the display mode

To adjust an alarm setpoint select 'SP1' or 'SP2' and press **P** which will reveal the current setting. The flashing digit of the setpoint may be adjusted using the ▲ and ▼ push buttons, and the **P** button to move control to the next digit. When the required setpoint has been entered, pressing **E** will return the display to the 'SP1' or 'SP2' prompt from which the other setpoint may be selected, or the indicator may be returned to the display mode by pressing **E** again.

Note: With the indicator in the display mode, direct access to the alarm setpoints is only available when the ACSP menu is enabled - see section 8.3.11

8.3.13 Displaying setpoints on bargraph

One of the selectable bargraph formats 'AlrSP' allows a low or a high setpoint plus the displayed value to be represented, or a low and a high setpoint plus the displayed value to be represented by the bargraph as shown in Fig 16.

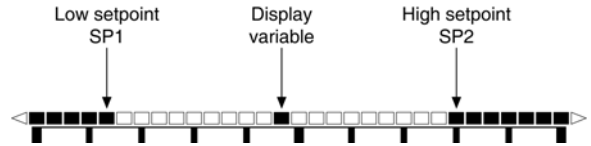

Fig 16 Displayed value and setpoints on bargraph

The bargraph area below the low alarm setpoint SP1 and the bargraph area above the high alarm setpoint SP2 are activated. The displayed variable is represented by an activated single bar which moves between the low and high alarm setpoints.

When the activated single bar representing the displayed variable is adjacent to the area representing the low or high alarm setpoints, the bar flashes. When the displayed variable equals the low or high alarm the complete bargraph representing the activated alarm flashes irrespective of whether the alarm output has been delayed or cleared.

For this function to operate SP1 must be conditioned as a low alarm and SP2 as a high alarm; SP1 must always be less than SP2. Incorrect configuration is shown by a flashing bargraph scale with no activated bars.

8.4 Display backlight

The BA507E-SS and the BA527E-SS loop powered indicators can be supplied with a factory fitted backlight that may be loop or separately powered.

When loop powered the backlight produces green background illumination enabling the display to be read at night or in poor lighting conditions. No additional power supply or field wiring are required, but the indicator voltage drop is increased. When separately powered the backlight is brighter, but an additional power supply and field wiring are required.

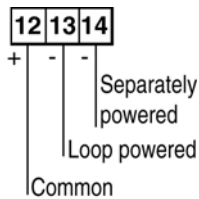

Fig 17 Terminals for optional backlight

8.4.1 Loop powering the backlight

The backlight is loop powered by connecting it in series with the indicator 4/20mA input as shown in Fig 18, which increases the maximum indicator voltage drop from 1.2 to 5V.

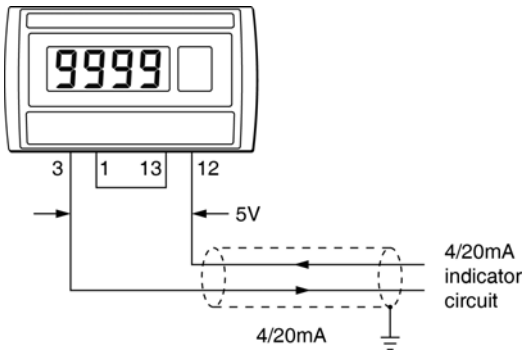

Fig 18 Loop powered backlight

8.4.2 Separately powering the backlight

The optional backlight may also be powered from a separate safe area power supply via an intrinsically safe interface as shown in Fig 19.

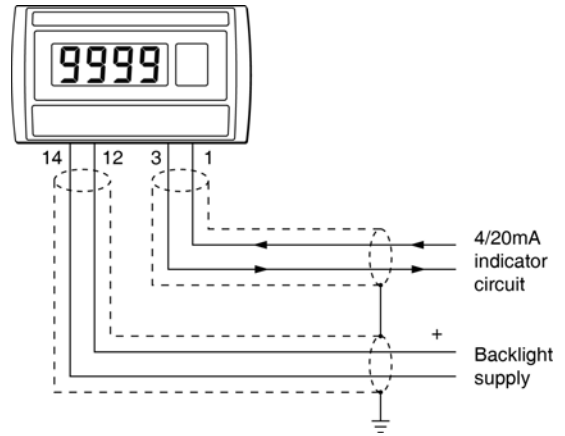

Fig 19 Separately powered backlight

When separately powered the backlight draws a constant 22mA current when the supply is equal to or greater the minimum specified voltage of 9V. Below this supply voltage the backlight continues to function but with reduced brilliance.