

Data Sheet

KFD2-SR2-EX2.W



Supplied by

247cable.com

Call us on +44 (0)118 916 9420 | Email info@247able.com

Switch Amplifier

KFD2-SR2-Ex2.W

Features

- 2-channel isolated barrier
- 24 V DC supply (Power Rail)
- Dry contact or NAMUR inputs
- Relay contact output
- Line fault detection (LFD)
- Reversible mode of operation
- Up to SIL2 acc. to IEC 61508

Function

This isolated barrier is used for intrinsic safety applications. It transfers digital signals (NAMUR sensors/mechanical contacts) from a hazardous area to a safe area.

The proximity sensor or switch controls a form C changeover relay contact for the safe area load. The normal output state can be reversed using switches S1 and S2. Switch S3 is used to enable or disable line fault detection of the field circuit.

During an error condition, the relays revert to their de-energized state and the LEDs indicate the fault according to NAMUR NE44.

A unique collective error messaging feature is available when used with the Power Rail system.

Assembly

Front view

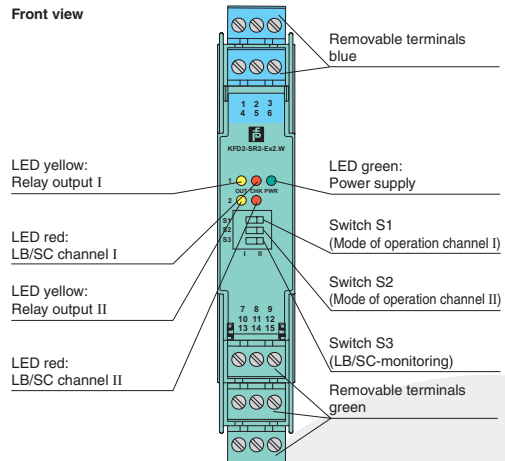

CE



SIL2

Connection

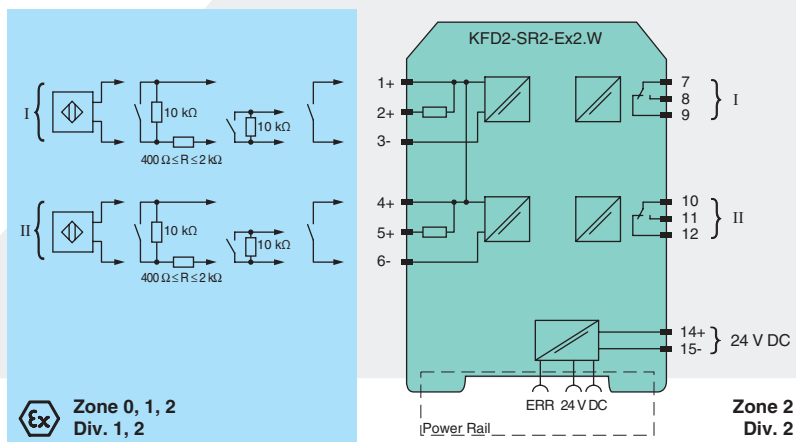

Technical data

KFD2-SR2-Ex2.W

General specifications	
Signal type	Digital Input
Supply	
Connection	Power Rail or terminals 14+, 15-
Rated voltage	20 ... 30 V DC
Ripple	≤ 10 %
Rated current	≤ 50 mA
Power loss	1 W
Power consumption	< 1.3 W
Input	
Connection	terminals 1+, 2+, 3-, 4+, 5+, 6-
Rated values	acc. to EN 60947-5-6 (NAMUR)
Open circuit voltage/short-circuit current	approx. 8 V DC / approx. 8 mA
Switching point/switching hysteresis	1.2 ... 2.1 mA / approx. 0.2 mA
Line fault detection	breakage $I \leq 0.1$ mA , short-circuit $I > 6$ mA
Pulse/Pause ratio	≥ 20 ms / ≥ 20 ms
Output	
Connection	output I: terminals 7, 8, 9 ; output II: terminals 10, 11, 12
Output I, II	signal, relay
Contact loading	253 V AC/2 A/cos $\phi > 0.7$; 126.5 V AC/4 A/cos $\phi > 0.7$; 40 V DC/2 A resistive load
Minimum switch current	2 mA / 24 V DC
Energized/De-energized delay	approx. 20 ms / approx. 20 ms
Mechanical life	10 ⁷ switching cycles
Transfer characteristics	
Switching frequency	≤ 10 Hz
Electrical isolation	
Input/Output	reinforced insulation according to IEC/EN 61010-1, rated insulation voltage 300 V _{eff}
Input/power supply	reinforced insulation according to IEC/EN 61010-1, rated insulation voltage 300 V _{eff}
Output/power supply	reinforced insulation according to IEC/EN 61010-1, rated insulation voltage 300 V _{eff}
Output/Output	reinforced insulation according to IEC/EN 61010-1, rated insulation voltage 300 V _{eff}
Directive conformity	
Electromagnetic compatibility	
Directive 2004/108/EC	EN 61326-1:2006
Low voltage	
Directive 2006/95/EC	EN 61010-1:2010
Conformity	
Electromagnetic compatibility	NE 21:2006
Protection degree	IEC 60529:2001
Input	EN 60947-5-6:2000
Ambient conditions	
Ambient temperature	-20 ... 60 °C (-4 ... 140 °F)
Mechanical specifications	
Protection degree	IP20
Mass	approx. 150 g
Dimensions	20 x 119 x 115 mm (0.8 x 4.7 x 4.5 in) , housing type B2
Mounting	on 35 mm DIN mounting rail acc. to EN 60715:2001
Data for application in connection with Ex-areas	
EC-Type Examination Certificate	PTB 00 ATEX 2080 , for additional certificates see www.pepperl-fuchs.com
Group, category, type of protection	Ⓔ II (1) G [Ex ia] IIC, II (1) D [Ex ia] IIIC
Input	[Ex ia] IIC, [Ex ia] IIIC
Voltage	U _o 10.5 V
Current	I _o 13 mA
Power	P _o 34 mW (linear characteristic)
Supply	
Maximum safe voltage	U _m 253 V AC / 125 V DC (Attention! U _m is no rated voltage.)
Output	
Contact loading	253 V AC/2 A/cos $\phi > 0.7$; 126.5 V AC/4 A/cos $\phi > 0.7$; 40 V DC/2 A resistive load
Maximum safe voltage	U _m 253 V AC (Attention! The rated voltage can be lower.)
Error message output	
Maximum safe voltage	U _m 40 V DC (Attention! U _m is no rated voltage.)
Statement of conformity	
Group, category, type of protection	Ⓔ II (3)G [Ex ic Gc] IIC
Input	[Ex ic] IIC

Reading Office

Cutbush Park, Danehill, Lower Earley,
Reading, Berkshire. RG6 4UT. UK.
Tel: +44 (0)118 9311188
Email: info@able.co.uk

Aberdeen Office

Unit 6 Airside Business Park, Kirkhill Industrial Estate,
Dyce, Aberdeen. AB21 0GT. UK.
Tel: +44 (0)1224 725999
Email: ab@able.co.uk

Internet: www.able.co.uk
e-procurement: www.247able.com
Registered in England No: 01851002
VAT No: GB 417 2481 61



Technical data

KFD2-SR2-Ex2.W

Voltage	U _o	10.5 V
Current	I _o	13 mA
Power	P _o	34 mW (linear characteristic)
Output		
Contact loading		253 V AC/2 A/cos φ > 0.7; 126.5 V AC/4 A/cos φ > 0.7; 40 V DC/2 A resistive load
Statement of conformity		
Group, category, type of protection, temperature class		⊕ II 3G Ex nA nC IIC T4
Output		
Contact loading		50 V AC/4 A/cos φ > 0.7; 40 V DC/2 A resistive load
Electrical isolation		
Input/Output		safe electrical isolation acc. to IEC/EN 60079-11, voltage peak value 375 V
Input/power supply		safe electrical isolation acc. to IEC/EN 60079-11, voltage peak value 375 V
Directive conformity		
Directive 94/9/EC		EN 60079-0:2009, EN 60079-11:2007, EN 60079-15:2005, EN 61241-11:2006
International approvals		
FM approval		
Control drawing		116-0035
CSA approval		
Control drawing		116-0047
IECEx approval		
Approved for		[Ex ia] IIC, [Ex ia] IIIC, [Ex ia] I
General information		
Supplementary information		EC-Type Examination Certificate, Statement of Conformity, Declaration of Conformity, Attestation of Conformity and instructions have to be observed where applicable. For information see www.pepperl-fuchs.com .

Technical data

KFD2-SR2-Ex2.W

Configuration

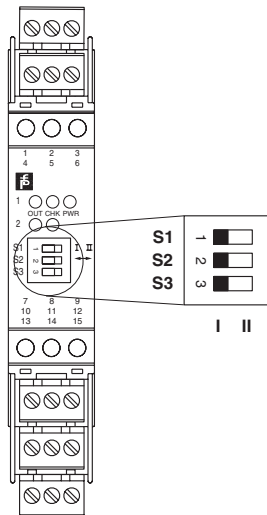

Switch position

S	Function	Position
1	Mode of operation Output I (relay) energized	I
	with low input current	II
2	Mode of operation Output II (relay) energized	I
	with low input current	II
3	Line fault detection	ON
		OFF

Operating status

Control circuit	Input signal
Initiator high impedance/ contact opened	low input current
Initiator low impedance/ contact closed	high input current
Lead breakage, lead short-circuit	Line fault

Factory settings: switch 1, 2 and 3 in position I

Accessories

Power feed module KFD2-EB2

The power feed module is used to supply the devices with 24 V DC via the Power Rail. The fuse-protected power feed module can supply up to 150 individual devices depending on the power consumption of the devices. A galvanically isolated mechanical contact uses the Power Rail to transmit collective error messages.

Power Rail UPR-03

The Power Rail UPR-03 is a complete unit consisting of the electrical inset and an aluminium profile rail 35 mm x 15 mm. To make electrical contact, the devices are simply engaged.

Profile Rail K-DUCT with Power Rail

The profile rail K-DUCT is an aluminum profile rail with Power Rail insert and two integral cable ducts for system and field cables. Due to this assembly no additional cable guides are necessary.



Power Rail and Profile Rail must not be fed via the device terminals of the individual devices!