

Data Sheet

KFD2-UT2-EX1



Supplied by

247able.com

Call us on +44 (0)118 916 9420 | Email info@247able.com

Universal Temperature Converter

KFD2-UT2-Ex1

Features

- 1-channel isolated barrier
- 24 V DC supply (Power Rail)
- Thermocouple, RTD, potentiometer or voltage input
- Current output 0/4 mA ... 20 mA
- Sink or source mode
- Configurable by **PACTware**
- Line fault (LFD) and sensor burnout detection
- Up to SIL2 acc. to IEC 61508/IEC 61511

Function

This isolated barrier is used for intrinsic safety applications. It is designed to connect RTDs, thermocouples, or potentiometers in the hazardous area, and provide a proportional 0/4 mA ... 20 mA signal to the safe area.

The barrier offers 3-port isolation between input, output, and power supply.

A removable terminal block K-CJC-** is available for thermocouples when internal cold junction compensation is desired.

A fault is indicated by a red flashing LED per NAMUR NE44 and user-configured fault outputs.

The unit is easily programmed with the **PACTware™** configuration software.

A collective error messaging feature is available when used with the Power Rail system.

For additional information, refer to the manual and www.pepperl-fuchs.com.

Assembly

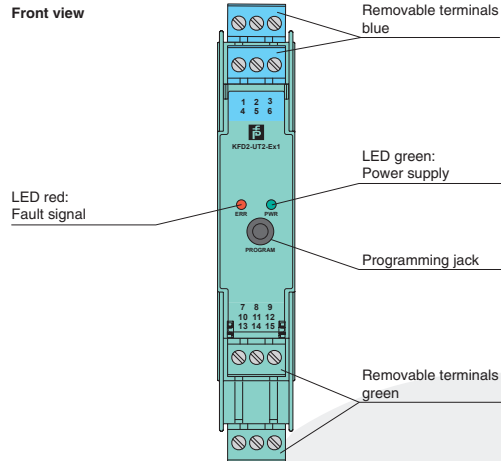

CE



SIL2

Connection

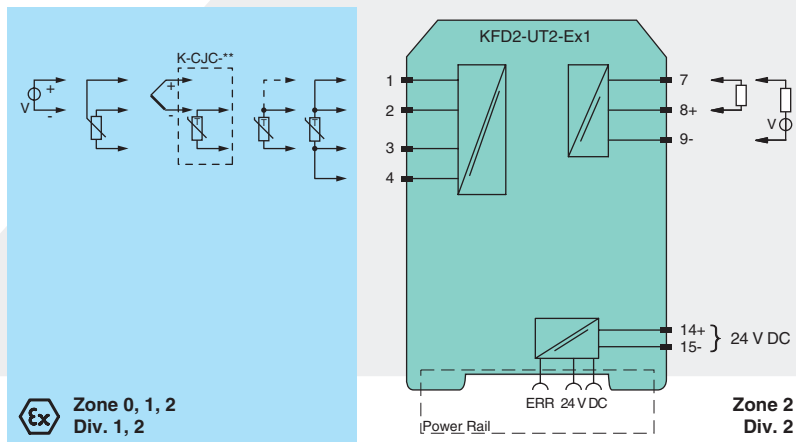

Zone 0, 1, 2
Div. 1, 2

Zone 2
Div. 2

Technical data

KFD2-UT2-Ex1

| | |
|-------------------------------------|---|
| General specifications | |
| Signal type | Analog input |
| Supply | |
| Connection | terminals 14+, 15- or power feed module/Power Rail |
| Rated voltage | 20 ... 30 V DC |
| Ripple | within the supply tolerance |
| Power loss/power consumption | ≤ 0.98 W / 0.98 W |
| Input | |
| Connection | terminals 1, 2, 3, 4 |
| RTD | type Pt10, Pt50, Pt100, Pt500, Pt1000 (EN 60751: 1995) type Pt10GOST, Pt50GOST, Pt100GOST, Pt500GOST, Pt1000GOST (6651-94) type Cu10, Cu50, Cu100 (P50353-92) type Ni100 (DIN 43760) |
| Measuring current | approx. 200 µA with RTD |
| Types of measuring | 2-, 3-, 4-wire connection |
| Lead resistance | ≤ 50 Ω per lead |
| Measuring circuit monitoring | sensor breakage, sensor short-circuit |
| Thermocouples | type B, E, J, K, N, R, S, T (IEC 584-1: 1995) type L (DIN 43710: 1985) type TXK, TXKH, TXA (P8.585-2001) |
| Cold junction compensation | external and internal |
| Measuring circuit monitoring | sensor breakage |
| Voltage | selectable within the range -100 ... 100 mV |
| Potentiometer | 0 ... 20 kΩ (2-wire connection), 0.8 ... 20 kΩ (3-wire connection) |
| Input resistance | ≥ 1 MΩ (-100 ... 100 mV) |
| Output | |
| Connection | output I: terminal 7: source (-), sink (+), terminal 8: source (+), terminal 9: sink(-) |
| Output | Analog current output |
| Current range | 0 ... 20 mA or 4 ... 20 mA |
| Fault signal | downscale 0 or 2 mA, upscale 21.5 mA (acc. NAMUR NE43) |
| Source | load 0 ... 550 Ω open-circuit voltage ≤ 18 V |
| Sink | Voltage across terminals 5 ... 30 V. If the current is supplied from a source > 16.5 V, series resistance of ≥ (V - 16.5)/0.0215 Ω is needed, where V is the source voltage. The maximum value of the resistance is (V - 5)/0.0215 Ω. |
| Transfer characteristics | |
| Deviation | |
| After calibration | Pt100: ± (0.06 % of measurement value in K + 0.1 % of span + 0.1 K (4-wire connection)) thermocouple: ± (0.05 % of measurement value in °C + 0.1 % of span + 1 K (1.2 K for types R and S)) this includes ± 0.8 K error of the cold junction compensation mV: ± (50 µV + 0.1 % of span) potentiometer: ± (0.05 % of full scale + 0.1 % of span, (excludes errors due to lead resistance)) |
| Influence of ambient temperature | deviation of CJC included: Pt100: ± (0.0015 % of measurement value in K + 0.006 % of span)/K ΔT _{amb} ¹⁾ thermocouple: ± (0.02 K + 0.005 % of measurement value in °C + 0.006 % of span)/K ΔT _{amb} ¹⁾ mV: ± (0.01 % of measurement value + 0.006 % of span)/K ΔT _{amb} ¹⁾ potentiometer: ± 0.006 % of span/K ΔT _{amb} ¹⁾ ¹⁾ ΔT _{amb} = ambient temperature change referenced to 23 °C (296 K) |
| Influence of supply voltage | < 0.01 % of span |
| Influence of load | ≤ 0.001 % of output value per 100 Ω |
| Reaction time | worst case value (sensor breakage and/or sensor short circuit detection enabled) mV: 1 s, thermocouples with CJC: 1.1 s, thermocouples with fixed reference temperature: 1.1 s, 3- or 4-wire RTD: 920 ms, 2-wire RTD: 800 ms, Potentiometer: 2.05 s |
| Electrical isolation | |
| Output/supply, programming input | functional insulation, rated insulation voltage 50 V AC There is no electrical isolation between the programming input and the supply. The programming cable provides galvanic isolation so that ground loops are avoided. |
| Directive conformity | |
| Electromagnetic compatibility | Directive 2004/108/EC |
| | EN 61326-1:2006 |
| Conformity | |
| Electromagnetic compatibility | NE 21:2006 |
| Degree of protection | IEC 60529:2001 |
| Protection against electrical shock | UL 61010-1:2004 |
| Ambient conditions | |
| Ambient temperature | -20 ... 60 °C (-4 ... 140 °F) |
| Mechanical specifications | |
| Degree of protection | IP20 |

Technical data

KFD2-UT2-Ex1

| | | |
|---|----------------|--|
| Mass | | approx. 130 g |
| Dimensions | | 20 x 119 x 115 mm (0.8 x 4.7 x 4.5 in) , housing type B2 |
| Mounting | | on 35 mm DIN mounting rail acc. to EN 60715:2001 |
| Data for application in connection with Ex-areas | | |
| EC-Type Examination Certificate | | CESI 04 ATEX 143 , for additional certificates see www.pepperl-fuchs.com |
| Group, category, type of protection | | ⊕ II (1)GD, I (M1), [Ex ia] IIC, [Ex iaD], [Ex ia] I (-20 °C ≤ T _{amb} ≤ 60 °C) [circuit(s) in zone 0/1/2] |
| Input | | Ex ia IIC |
| Inputs | | terminals 1, 2, 3, 4 |
| Voltage | U _o | 9 V |
| Current | I _o | 22 mA |
| Power | P _o | 50 mW |
| Analog outputs, power supply, collective error | | |
| Maximum safe voltage | U _m | 250 V (Attention! This is not the rated voltage.) |
| Interface | | |
| Maximum safe voltage | U _m | 250 V (Attention! The rated voltage is lower.), RS 232 |
| Statement of conformity | | |
| Group, category, type of protection, temperature class | | ⊕ II 3G Ex nA II T4 [device in zone 2] |
| Electrical isolation | | |
| Input/Other circuits | | safe electrical isolation acc. to IEC/EN 60079-11, voltage peak value 375 V |
| Directive conformity | | |
| Directive 94/9/EC | | EN 60079-0:2012 EN 60079-11:2012 EN 60079-15:2005 EN 60079-26:2007 EN 50303:2000 |
| International approvals | | |
| UL approval | | |
| Control drawing | | 116-0316 |
| CSA approval | | |
| Control drawing | | 366-024CS-12 (cCSAus) |
| IECEx approval | | |
| Approved for | | [Zone 0] [Ex ia] IIC, [Ex iaD], [Ex ia] I |
| General information | | |
| Supplementary information | | EC-Type Examination Certificate, Statement of Conformity, Declaration of Conformity, Attestation of Conformity and instructions have to be observed where applicable. For information see www.pepperl-fuchs.com . |

Accessories

Power feed module KFD2-EB2

The power feed module is used to supply the devices with 24 V DC via the Power Rail. The fuse-protected power feed module can supply up to 150 individual devices depending on the power consumption of the devices. A galvanically isolated mechanical contact uses the Power Rail to transmit collective error messages.

Power Rail UPR-03

The Power Rail UPR-03 is a complete unit consisting of the electrical inset and an aluminium profile rail 35 mm x 15 mm. To make electrical contact, the devices are simply engaged.

Profile Rail K-DUCT with Power Rail

The profile rail K-DUCT is an aluminum profile rail with Power Rail insert and two integral cable ducts for system and field cables. Due to this assembly no additional cable guides are necessary.



Power Rail and Profile Rail must not be fed via the device terminals of the individual devices!

K-CJC-**

This removable terminal block with integrated temperature measurement sensor is needed for internal cold junction compensation for thermocouples. One K-CJC-** is needed for each channel.

PACTware™

Device-specific drivers (DTM)

Adapter K-ADP-USB

Programming adapter for parameterisation via the serial USB interface of a PC/Notebook

Reading Office

Cutbush Park, Danehill, Lower Earley,
Reading, Berkshire. RG6 4UT. UK.
Tel: +44 (0)118 9311188
Email: info@able.co.uk

Aberdeen Office

Unit 6 Airside Business Park, Kirkhill Industrial Estate,
Dyce, Aberdeen. AB21 0GT. UK.
Tel: +44 (0)1224 725999
Email: ab@able.co.uk

Internet: www.able.co.uk
e-procurement: www.247able.com
Registered in England No: 01851002
VAT No: GB 417 2481 61

