

Installation & Maintenance Instructions

BA304G & BA324G

Intrinsically Safe Loop-Powered Field Mounting Indicators



Supplied by

247able.com

Call us on +44 (0)118 916 9420 | Email info@247able.com

BA304G & BA324G
intrinsically safe
loop-powered
field mounting indicators
Issue 1

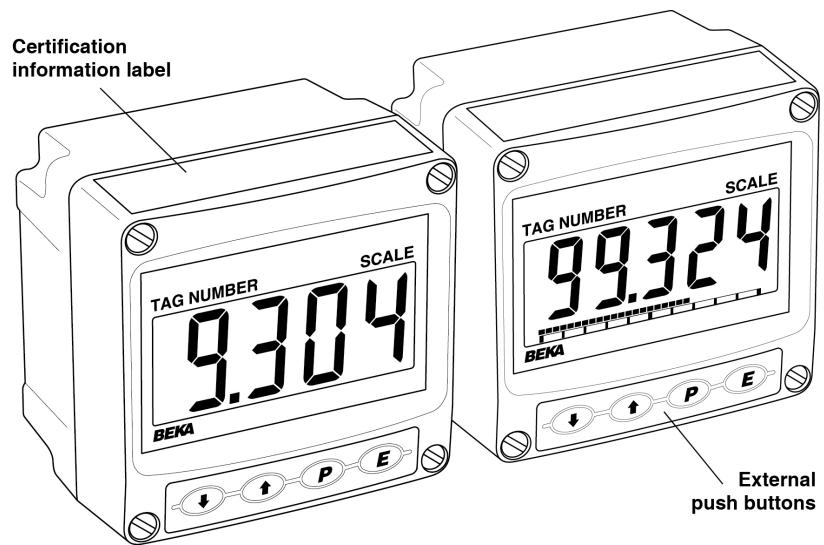

CONTENTS

- | | |
|---|--|
| <p>1. Description</p> <p>2. Operation</p> <p>2.1 Controls</p> <p>3. Intrinsic safety certification</p> <p>3.1 ATEX gas certification</p> <p>3.2 Zones, gas groups & T rating</p> <p>3.3 4/20mA input</p> <p>3.4 Certification label information</p> <p>4. System Design for Gas Hazardous Areas</p> <p>4.1 Transmitter loops</p> <p>4.2 Remote indication</p> <p>5. Installation</p> <p>5.1 Location</p> <p>5.2 Installation procedure</p> <p>5.3 EMC</p> <p>5.4 Units of measurement and tag marking on scale card.</p> <p>6. Configuration and Calibration</p> <p>6.1 Summary of configuration functions</p> <p>6.2 Indicator function: F_{un}</p> <p>6.3 Resolution: $rE5n$</p> <p>6.4 Position of the decimal point: dP</p> <p>6.5 Calibration using an external current source: CR_L</p> <p>6.6 Calibration using internal reference: $5Et$</p> <p>6.7 Bargraph format and calibration: bRr</p> <p>6.8 Function of the \square push-button: $[- - P$</p> <p>6.9 Tare function: $tRrE$</p> <p>6.10 Security code: $[odE$</p> <p>6.11 Reset to factory defaults: $r5Et$</p> <p>6.12 Under and over-range</p> <p>7. Lineariser</p> <p>7.1 Lineariser calibration using an external current source.</p> <p>7.1.1 Example, Adding break-points indicator</p> <p>7.2 Lineariser calibration using internal reference.</p> <p>7.2.1 Example, Adding break-points to a new indicator</p> <p>7.3 Under and over-range</p> | <p>8. Maintenance</p> <p>8.1 Fault finding during commissioning</p> <p>8.2 Fault finding after commissioning</p> <p>8.3 Servicing</p> <p>8.4 Routine maintenance</p> <p>8.5 Guarantee</p> <p>8.6 Customer comments</p> <p>9. Accessories</p> <p>9.1 Units of measurement and instrument identification.</p> <p>9.2 Display backlight</p> <p>9.2.1 Loop powering the backlight</p> <p>9.2.2 Separately powering the backlight</p> <p>9.3 Alarms</p> <p>9.3.1 Solid state output</p> <p>9.3.2 Intrinsic safety</p> <p>9.3.3 Configuration and adjustment.</p> <p>9.3.4 Alarm enable: $EnbL$</p> <p>9.3.5 Setpoint adjustment: $5P1$ and $5P2$.</p> <p>9.3.6 Alarm function: $H.La$</p> <p>9.3.7 Alarm output status: $no.n$</p> <p>9.3.8 Hysteresis: $H5tr$</p> <p>9.3.9 Alarm delay: $dELR$</p> <p>9.3.10 Alarm silence time: $5iL$</p> <p>9.3.11 Flash display when alarm occurs: $FL5H$</p> <p>9.3.12 Access setpoint in display mode: $RE5P$.</p> <p>9.3.13 Adjusting alarm setpoints from the display mode.</p> <p>9.3.14 Display setpoints on BA324G bargraph.</p> <p>9.4 Pipe mounting kit</p> <p>9.5 Back-box terminal assembly</p> <p>Appendix 1 ATEX dust certification</p> <p>Appendix 2 IECEx gas and dust certification</p> |
|---|--|

1. DESCRIPTION

These field mounting, intrinsically safe digital indicators display the current flowing in a 4/20mA loop in engineering units. They are loop powered but only introduce a 1.2V drop, which allows them to be installed into almost any 4/20mA current loop. No additional power supply or battery is required.

The two models are electrically similar, but have different size displays.

Model	Display
BA304G	4 digits 34mm high
BA324G	5 digits 29mm high and 31 segment bargraph.

This instruction manual supplements the instruction sheet supplied with each instrument.

The main application of both models is to display a measured variable or control signal in a hazardous process area. The zero and span of the display are independently adjustable so that the indicator can be calibrated to display any variable represented by the 4/20mA current, e.g. temperature, flow, pressure or level.

Both models have been certified intrinsically safe for use in gas and dust hazardous areas by Notified Body Intertek Testing and Certification Ltd and comply with the European ATEX Directive 94/9/EC. The EC-Type Examination certificate specifies that under fault conditions the output voltage, current and power at the 4/20mA input terminals will not exceed those specified for *simple apparatus* in Clause 5.7 of EN 60079-11, which simplifies installation and documentation.

For international applications both models have IECEx certification which is described in Appendix 2.

2. OPERATION

Fig 1 shows a simplified block diagram of both models. The 4/20mA input current flows through resistor R1 and forward biased diode D1. The voltage developed across D1, which is relatively constant, is multiplied by a switch mode power supply and used to power the instrument. The voltage developed across R1, which is proportional to the 4/20mA input current, provides the input signal for the analogue to digital converter.

Each time a 4/20mA current is applied to the instrument, initialisation is performed during which all segments of the display are activated, after five seconds the instrument displays the input current using the calibration information stored in the instrument memory. If the loop current is too low to power the instrument the indicator will display the error message L.P.L.O.

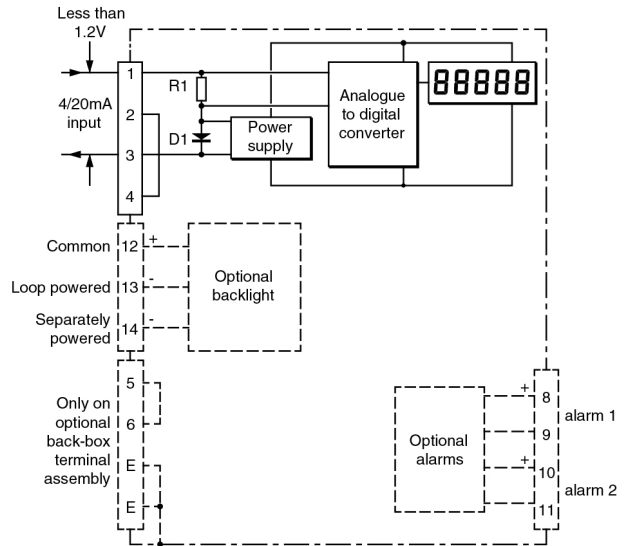

Fig 1 Indicator block diagram

2.1 Controls

Both models are controlled and calibrated via four front panel push buttons. In the display mode i.e. when the indicator is displaying a process variable, these push buttons have the following functions:

- P While this button is pushed the indicator will display the input current in mA, or as a percentage of the instrument span depending upon how the indicator has been configured. When the button is released the normal display in engineering units will return. The function of this push button is modified when optional alarms are fitted to the indicator.
- ▼ While this button is pushed the indicator will display the numerical value and analogue bargraph* the indicator has been calibrated to display with a 4mA^φ input. When released the normal display in engineering units will return.
- ▲ While this button is pushed the indicator will display the numerical value and analogue bargraph* the indicator has been calibrated to display with a 20mA^φ input. When released the normal display in engineering units will return.
- E No function in the display mode unless the tare function is being used.
- P + ▼ Indicator displays firmware number followed by version.
- P + ▲ Provides direct access to the alarm setpoints when the indicator is fitted with optional alarms and the *RESP* access setpoints function has been enabled.
- P + E Provides access to the configuration menu via optional security code.

Note:

- * BA324G only
- φ If the indicator has been calibrated using the CAL function, calibration points may not be 4 and 20mA.

3. INTRINSIC SAFETY CERTIFICATION

Both models have ATEX and IECEx gas and dust certification. This section of the instruction manual describes ATEX gas certification. ATEX dust and IECEx approvals are described in Appendixes 1 and 2.

3.1 ATEX gas certification

Notified Body Intertek Testing and Certification Ltd have issued both models with a common EC-Type Examination Certificate number ITS11ATEX27253X. This confirms compliance with harmonised European standards and it has been used to confirm compliance with the European ATEX Directive for Group II, Category 1G equipment, Ex ia IIC T5 Ga Ta = -40 to +70°C. The indicators carry the community mark and, subject to local codes of practice, may be installed in any of the European Economic Area (EEA) member countries. ATEX certificates are also acceptable for installations in Switzerland.

This section of the instruction manual describes ATEX installations in explosive gas atmospheres conforming with EN60079-14 *Electrical installations design, selection and erection*. When designing systems for installation outside the UK the local Code of Practice should be consulted.

3.2 Zones, gas groups and T rating

Both indicators have been certified Ex ia IIC T5. When connected to a suitable system they may be installed in:

Zone 0	explosive gas air mixture continuously present.
Zone 1	explosive gas air mixture likely to occur in normal operation.
Zone 2	explosive gas air mixture not likely to occur, and if it does will only exist for a short time.

Be used with gases in groups:

Group A	propane
Group B	ethylene
Group C	hydrogen

In gases that may be used with equipment having a temperature classification of:

T1	450°C
T2	300°C
T3	200°C
T4	135°C
T5	100°C

At ambient temperatures between -40 and +70°C.

WARNING installation in Zone 0

When installed in a Zone 0 potentially explosive atmosphere requiring EPL Ga apparatus, the instrument shall be installed such that even in the event of rare incidents, an ignition source due to impact or friction between the aluminium label and iron/steel is excluded.

No special conditions apply when the indicator is installed in Zone 1 or in Zone 2.

This allows both models to be installed in all gas Zones and to be used with most common industrial gases except carbon disulphide and ethyl nitrite which have an ignition temperature of 95°C.

3.3 4/20mA input

The input safety parameters for the 4/20mA input, terminals 1 and 3 are:

U_i	=	30V dc
I_i	=	200mA
P_i	=	0.84W

The maximum equivalent capacitance and inductance between the two 4/20mA input terminals 1 and 3 is:

C_i	=	5.4nF
L_i	=	0.016mH (0.02mH)

The maximum permitted loop cable parameters can be calculated by adding these figures to C_i and L_i of other instruments in the loop and subtracting the totals from the maximum cable capacitance C_o and cable inductance L_o permitted for the Zener barrier or galvanic isolator powering the loop.

Although the indicators do not themselves comply with the requirements for *simple apparatus*, the EC-Type Examination Certificate states that for intrinsic safety considerations, under fault conditions the output voltage, current and power at terminals 1 & 3 will not exceed those specified by clause 5.7 of EN 60079-11 for *simple apparatus*. This simplifies the application and intrinsic safety documentation for a loop into which an indicator is connected.

3.4 Certification label information

The certification information label is fitted on the top surface of the instrument assembly. It shows the ATEX and IECEx certification information and BEKA associates name and location. Non European certification information may also be shown. The instrument serial number and date of manufacturer are recorded on a separate label inside the instrument enclosure.

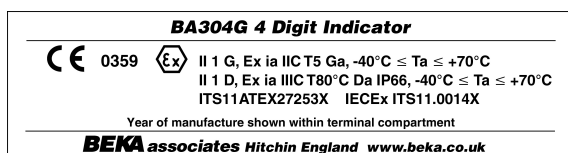

BA304G certification label

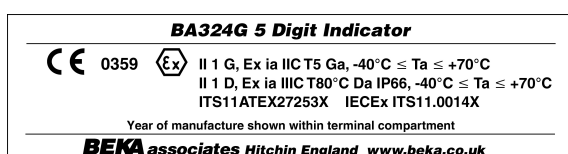

BA324G certification label

4. SYSTEM DESIGN FOR GAS HAZARDOUS AREAS.

4.1 Transmitter loops

Both models may be connected in series with almost any intrinsically safe 4/20mA current loop and calibrated to display the measured variable or control signal in engineering units. There are three basic design requirements:

1. The intrinsic safety output parameters of the 4/20mA loop, which are defined by the Zener barrier or galvanic isolator powering the loop, must be equal to or less than:

U_o	=	30V dc
I_o	=	200mA
P_o	=	0.84W

2. The maximum permitted cable capacitance of the loop, defined by the Zener barrier or galvanic isolator powering the loop, must be reduced by 5.4nF and the maximum permitted cable inductance by 0.02mH.
3. The loop must be able to tolerate the additional 1.2V required to operate the indicator. When fitted with an optional backlight this increases to 5.0V if the backlight is loop powered. See 9.2.1

Figs 2a and 2b illustrate typical applications in which an indicator is connected in series with a 2-wire transmitter powered by a Zener barrier and alternatively by a galvanic isolator.

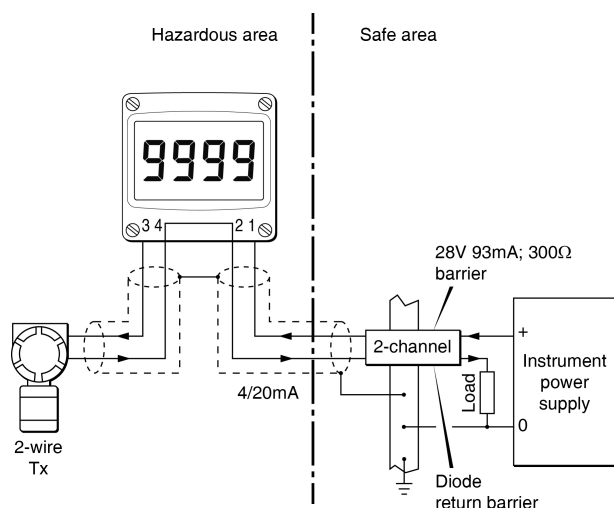

Fig 2a Loop powered by a Zener barrier

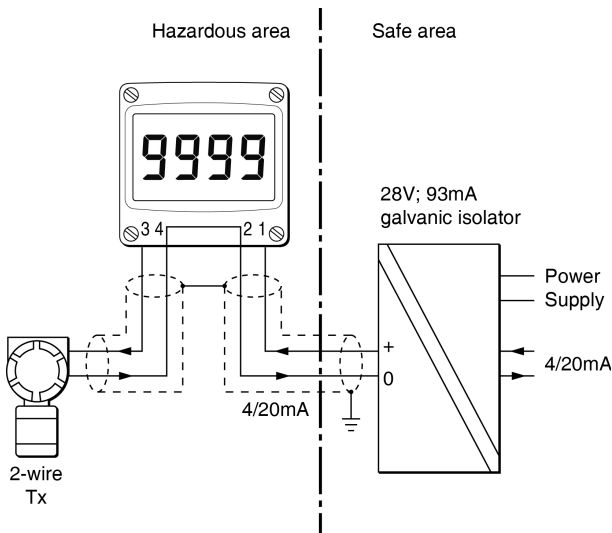

Fig 2b Loop powered by a galvanic isolator

4.2 Remote indication

Both indicators may be driven via an intrinsically safe interface from a 4/20mA safe area signal to provide a remote display within a hazardous area. The type of intrinsically safe interface is not critical, either a Zener barrier or a galvanic isolator may be used, providing that U_i , I_i and P_i of the indicator are not exceeded and the voltage capability of the 4/20mA signal is sufficient to drive the indicator plus the interface.

When a high integrity earth connection is already available, a Zener barrier is usually the least expensive option. If an earth connection is not available or isolation is required, a galvanic isolator is the correct choice.

If one side of the 4/20mA current loop may be earthed, a single channel Zener barrier provides the lowest cost protection. If the 4/20mA signal is not isolated, then two Zener barriers, a two channel Zener barrier or a galvanic isolator must be used.

Fig 3 shows the alternative circuits which may be used.

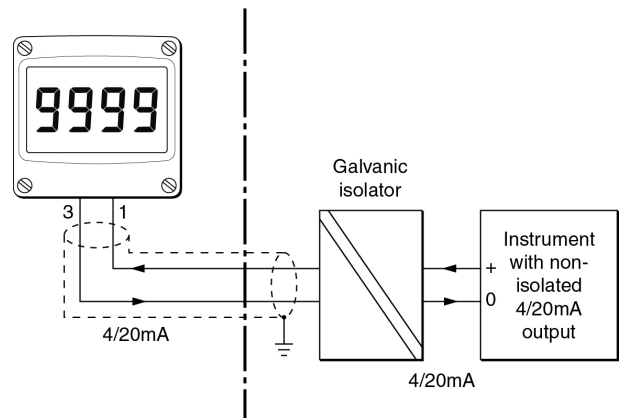
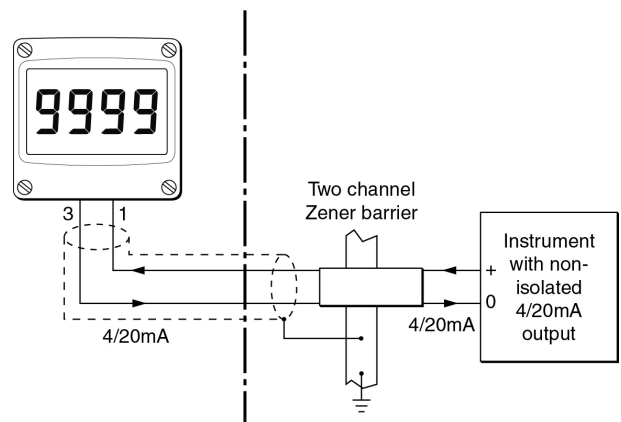
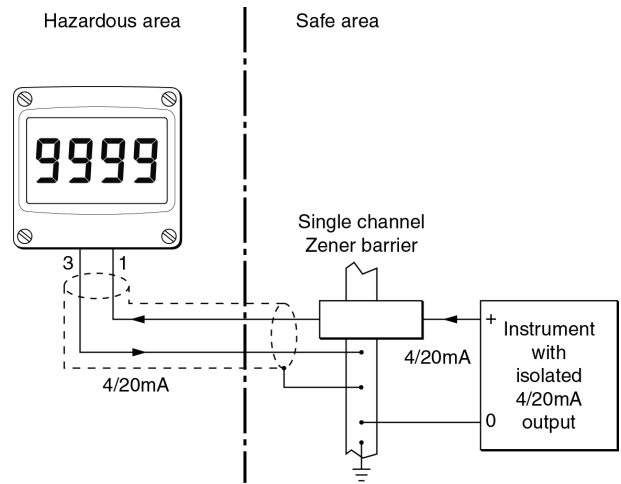

Fig 3 Alternative circuits for remote indication in a hazardous area

5. INSTALLATION

5.1 Location

The BA304G and BA324G indicators are housed in robust IP66 glass reinforced polyester (GRP) enclosures incorporating an armoured glass window and stainless steel fittings making them suitable for exterior mounting in most industrial on-shore and off-shore installations. The indicators should be positioned where the display is not in continuous direct sunlight. Special conditions apply for Zone 0 installations, see section 3.2.

Field wiring terminals are located on the rear of the indicator assembly as shown in Fig 5. If the field wiring is to be terminated prior to the installation of the indicator assembly, a back-box terminal assembly, which includes a 4/20mA continuity diode and additional terminals for linking cable screens is available as an option. See section 9.5 of this manual.

Indicator terminals 2 and 4 are internally joined and may be used for linking the return 4/20mA wire - see Fig 2.

The enclosures are fitted with a bonding plate to ensure electrical continuity between the two conduit or cable entries which includes an M4 earth stud and may be mounted on the inside or outside of the enclosure. If the carbon loaded GRP enclosure is not bolted to an earthed post or structure, this earth stud should be connected to the plant potential equalising conductor.

Both indicators are surface mounting, but may be pipe mounted using one of the accessory kit described in section 9.4 of this manual.

5.2 Installation Procedure

Fig 4 illustrates the instrument installation procedure.

- A. Remove the indicator assembly by unscrewing the four captive 'A' screws.
- B. Mount the enclosure back-box on a flat surface and secure with screws or bolts through the four 'B' holes. Alternatively use one of the pipe mounting kits described in section 9.4.
- C. Remove the temporary hole plug and install an appropriate IP and temperature rated cable gland or conduit fitting. If two entries are required, the IP66 stopping plug should be replaced with an appropriate IP and temperature rated cable gland or conduit fitting.
- D. Connect the field wiring to the terminals as shown in Fig 5. Replace the instrument assembly on the back-box and evenly tighten the four 'A' screws.

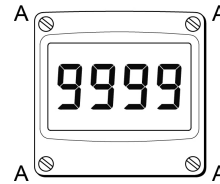

Step A

Unscrew the four captive 'A' screws and separate the indicator assembly and the back-box.

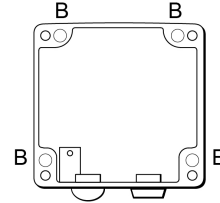

Step B

Secure the enclosure back-box to a flat surface with M6 screws through the four 'B' holes. Alternatively use a pipe mounting kit.

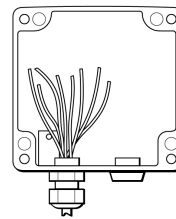

Step C

Remove the temporary hole plug and install an appropriate IP rated cable gland or conduit fitting. Feed the field wiring through the cable entry.

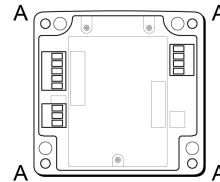

Step D

Terminate field wiring on the indicator assembly. Replace the indicator assembly on the enclosure back-box and tighten the four 'A' screws.

Fig 4 BA304G & BA324G installation procedure

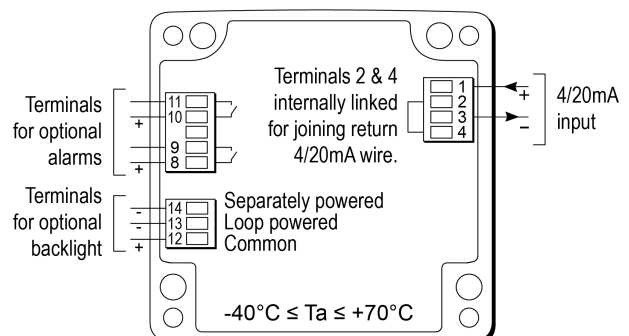
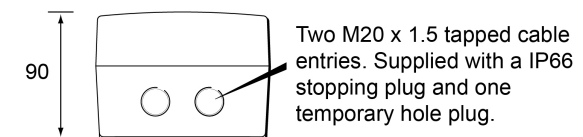
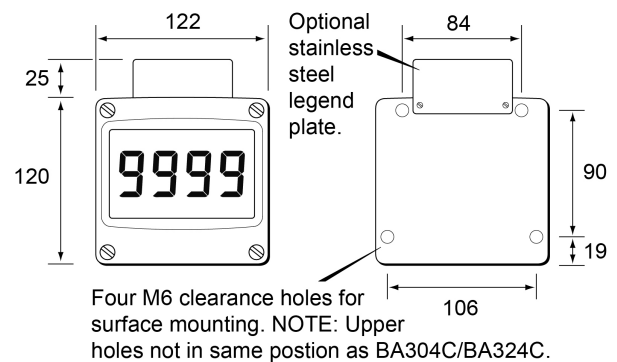

Fig 5 Dimensions and terminal connections

5.3 EMC

Both instruments comply with the requirements of the European EMC Directive 2004/108/EC. For specified immunity all wiring should be in screened twisted pairs, with the screens earthed at one point in the safe area.

The optional back-box terminal assembly, which is described in section 9.5, includes a pair of isolated linked terminals 5 and 6 for joining cable screens.

5.4 Units of measurement and tag marking on scale card.

The indicator's units of measurement and tag information are shown on a scale card which slides into the indicator.

New indicators are supplied with a printed scale card showing the requested units of measurement and tag information. If this information is not supplied when the indicator is ordered, a blank scale card will be fitted which can easily be marked on-site with a dry transfer or a permanent marker. Custom printed scale cards are available from BEKA associates as an accessory.

To remove the scale card from an indicator carefully pull the transparent tab at the rear of the indicator assembly away from the indicator as shown in Fig 6a.

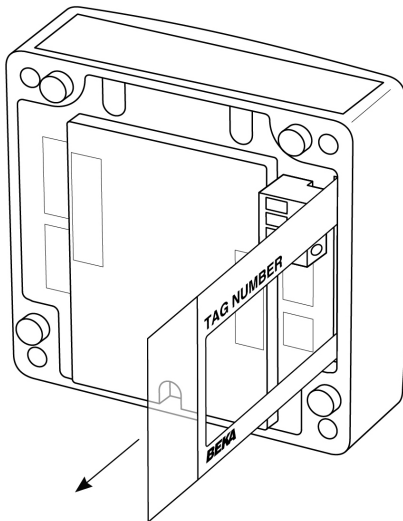

Fig 6a Removing scale card

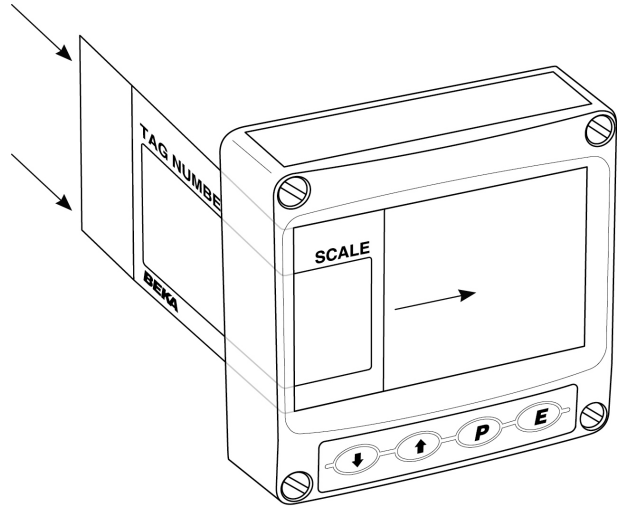

Fig 6b Inserting scale card into the instrument assembly.

To replace the scale card carefully insert it into the slot on the right hand side of the input terminals as shown in Fig 6b. Force should be applied evenly to both sides of the scale card to prevent it twisting. The card should be inserted until about 2mm of the transparent tab remains protruding.

6. CONFIGURATION AND CALIBRATION

Both indicators are configured and calibrated via the four front panel push buttons. All the configuration functions are contained in an easy to use intuitive menu that is shown diagrammatically in Fig 7.

Each menu function is summarised in section 6.1 and includes a reference to more detailed information. When the indicator is fitted with alarms additional functions are added to the menu which are described in section 9.3

Throughout this manual push buttons are shown as **P**, **E**, **▼** or **▲**, and legends displayed by the indicator are shown within inverted commas e.g. `LR1` and `RLr2`.

Access to the configuration menu is obtained by operating the **P** and **E** push buttons simultaneously. If the indicator security code is set to the default `0000` the first parameter `Func` will be displayed. If a security code other than the default code `0000` has already been entered, the indicator will display `Code`. Pressing the **P** button will clear this prompt allowing each digit of the code to be entered using the **▼** and **▲** push buttons and the **P** button to move control to the next digit. When the correct four digit code has been entered pressing **E** will cause the first parameter `Func` to be displayed. If the code is incorrect, or a button is not pressed within twenty seconds, the indicator will automatically return to the display mode.

Once within the configuration menu the required parameter can be reached by scrolling through the menu using the **▼** and **▲** push buttons as shown in Fig 7. When returning to the display mode following recalibration or a change to any function, the indicator will display `ERR` followed by `SAVE` while the new information is stored in permanent memory.

All new indicators are supplied calibrated as requested at the time of ordering. If calibration is not requested, indicators will be supplied with the following default configuration:

Default Configuration

	BA304G	BA324G
Access code <code>Code</code>	0000	0000
Function <code>Func</code>	Linear	Linear
Display at 4mA <code>Zero</code>	0.0	0.00
Display at 20mA <code>Span</code>	100.0	100.00
Resolution <code>Res</code>	1 digit	1 digit
Bargraph start <code>BarLo</code>	----	0.00
Bargraph finish <code>BarHi</code>	----	100.00
P button in display mode <code>LR1</code>	%	%
Tare <code>RLrE</code>	Off	Off

6.1 Summary of configuration functions

This section summarises each of the main configuration functions and includes a cross reference to a more detailed description. Fig 7 illustrates the location of each function within the configuration menu. The lineariser and the optional factory fitted alarms are described separately in sections 7 and 9.3 of this manual.

Display	Summary of function
---------	---------------------

`Func` Indicator function

Defines the relationship between the 4/20mA input current and the indicator display. May be set to:

- `Std` Standard linear relationship
- `Root` Square root extraction
- `Lin` 16 segment adjustable lineariser – see section 7.

See section 6.2

`Res` Display resolution

Defines the resolution of the least significant display digit. May be set to 1, 2, 5 or 10 digits.

See section 6.3

`dP` Decimal point

Positions a dummy decimal point between any of the digits or turns it off.

See section 6.4

`LR1` Calibration of the digital display using an external current source.

Enables the zero and span of the indicator to be adjusted using an external current source such as a calibrator. When used with an accurate traceable current source this is the preferred method of calibration.

See section 6.5

`SE1` Calibration of display using internal references.

Enables the zero and span of the indicator to be adjusted without the need for an accurate input current or disconnection from the 4/20mA loop. See section 6.6

`Bar` Bargraph format and calibration

Only the BA324G has a bargraph

The bargraph may be conditioned to start from left, right or centre of the display, or it may be disabled. When optional alarms are fitted it can also display both alarm setpoints and the measured value. The bargraph may be calibrated to start and finish at any value within the indicator's calibrated digital display.

See section 6.7

Display	Summary of function
---------	---------------------

[-][P] **Function of [P] push button**

The indicator may be configured to display the input current in milliamps, or the input current as a percentage of the 4/20mA input when the [P] push button is operated in the display mode.

See section 6.8

[R][E] **Tare function**

When enabled the tare function sets the indicator display to zero when the [E] push button is operated in the display mode.

See section 6.9

[od] **Security code**

Defines a four digit numeric code that must be entered to gain access to the configuration menu. Default code 0000 disables this security function and allows unrestricted access to all conditioning functions.

See section 6.10

[5E] **Reset**

Contains two sub-functions, [on]F which returns the indicator to the default conditions shown in section 6.0 and [LR]b which returns the lineariser to the default conditions shown in section 7.3. To prevent accidental use both resets must be confirmed by entering 5urE before they will be executed.

See section 6.11

6.2 Indicator function: FunC

This configuration function defines the relationship between the indicator's 4/20mA input current and the indicator's display. Three alternatives are available:

5Ed	Standard linear relationship
root	Square root extraction
Lin	16 segment adjustable lineariser

To reveal the existing indicator function select FunC from the configuration menu and press [P]. If the function is set as required, press [E] to return to the menu, or press the [v] or [^] button to change the setting, followed by the [E] button to return to the configuration menu.

5Ed **Linear**

Provides a linear relationship between the 4/20mA indicator input current and the indicator display.

root **Square root extraction**

Primarily intended to linearise the square law 4/20mA output from differential flowmeters.

For reference, the following table shows the output current from a non-linearised differential flowmeter.

% of full flow	Current output mA
2.5	4.01
10.0	4.16
25.0	5.00
50.0	8.00
75.0	13.00
100.0	20.00

When the root function is selected the indicator will display flow in linear units.

Lin **16 segment adjustable lineariser**

Enables non-linear variables to be displayed by the indicator in linear engineering units. Use of the lineariser is described in section 7 of this instruction manual.

6.3 Resolution: rE5n

This function defines the resolution of the least significant display digit. Decreasing the display resolution can improve the readability of a noisy signal. Select rE5n from the menu and press [P] which will reveal the current display resolution. To change the resolution press the [v] or [^] button to select 1, 2, 5 or 10 digits, followed by the [E] button to enter the selection and return to the configuration menu.

6.4 Position of the decimal point: dP

A dummy decimal point can be positioned between any of the digits or it may be absent. To position the decimal point select dP from the menu and press \mathbf{P} . The decimal point can be moved by pressing the \blacktriangledown or \blacktriangle push button. If a decimal point is not required it should be positioned beyond the most or least significant digit. When positioned as required press the \mathbf{E} button to enter the selection and return to the configuration menu.

6.5 Calibration using an external current source: $[RL]$

This function enables the zero and span of the indicator to be adjusted using an external calibrated current source. When used with an accurate traceable current source this is the preferred method of calibration.

Zero is the indicator display with 4mA input
Span is the indicator display with 20mA input

To calibrate the indicator select $[RL]$ from the configuration menu and press \mathbf{P} . The indicator will display $ZEro$ which is a request for a 4mA input current. Adjust the external current calibrator to 4.000mA and again press \mathbf{P} which will reveal the current zero display. The flashing digit of the indicator display can be changed by pressing the \blacktriangledown or \blacktriangle buttons, when set as required pressing \mathbf{P} will transfer control to the next digit. When all the digits have been adjusted, press \mathbf{E} to enter the new zero and return to the $ZEro$ prompt.

Pressing the \blacktriangle button will cause the indicator to display $5PRn$ which is a request for a 20mA input current. Adjust the external current calibrator to 20.000mA and again press \mathbf{P} which will reveal the existing span display. The flashing digit of the indicator display can be changed by pressing the \blacktriangledown or \blacktriangle buttons, when set as required pressing \mathbf{P} will transfer control to the next digit. When all the digits have been adjusted press \mathbf{E} to enter the new span and return to the $5PRn$ prompt. Finally press \mathbf{E} again to return to the configuration menu.

Notes:

- The indicator input current must be adjusted to the required value before the zero and span functions are entered by pressing the \mathbf{P} button.
- Indicators may be calibrated at currents other than 4 and 20mA, within the range 3.8 to 21.0mA providing the difference between the two currents is greater than 4mA. If these conditions are not complied with, the indicator displays FR, L and aborts the calibration.
- If the zero current is greater than the span current the instrument will be reverse acting i.e. an increasing input current will cause the display to decrease.

6.6 Calibration using internal reference: $5Et$

Using the $5Et$ function the indicator can be calibrated without the need to know the value of the 4/20mA input current, or to disconnect the indicator from the 4/20mA loop.

When using the $5Et$ function the indicator's internal reference is used to simulate a 4mA and 20mA input current.

Zero is the display with a simulated 4mA input
Span is the display with a simulated 20mA input

To calibrate the indicator display select $5Et$ from the configuration menu and press \mathbf{P} . The indicator will display $ZEro$, pressing \mathbf{P} again will reveal the current display at 4mA. The flashing digit can be adjusted by pressing the \blacktriangledown or \blacktriangle buttons, when the flashing digit is correct pressing \mathbf{P} will transfer control to the next digit. When all the digits have been adjusted, press \mathbf{E} to return to the $ZEro$ prompt.

To adjust the display at 20mA, press the \blacktriangle button which will cause the indicator to display $5PRn$, pressing \mathbf{P} will then reveal the indicator's existing display at 20mA. The flashing digit can be adjusted by pressing the \blacktriangledown or \blacktriangle buttons, when the flashing digit is correct pressing \mathbf{P} will transfer control to the next digit. When all the digits have been adjusted press \mathbf{E} to return to the $5PRn$ prompt followed by \mathbf{E} to return to the $5Et$ prompt in the configuration menu.

6.7 Bargraph format and calibration: bRr

Only the BA324G has a bargraph

In addition to a five digit numerical display the BA324G has a 31 segment analogue bargraph which may be configured to start and finish anywhere within the indicator's numerical display range.

To configure the bargraph select bRr from the configuration menu and press \mathbf{P} . The indicator will display $LYPE$, pressing \mathbf{P} again will reveal the existing bargraph justification which can be changed to one of the following four or five options using the \blacktriangledown or \blacktriangle button:

Bargraph justification starts from	
$LEFE$	Left end of display
$CEnter$	Centre of display
ri, rHE	Right end of display
$RLr5P$	Only with alarms - see section 9.3
oFF	Bargraph disabled

When set as required press \mathbf{E} to return to the $LYPE$ sub-function prompt.

The indicator's digital display at which the bargraph starts is defined by the `bRRLo` sub-function which is selected by pressing the \blacktriangle button followed by the P button which will reveal the current indicator display at which the bargraph starts. The flashing digit can be adjusted by pressing the \blacktriangledown or \blacktriangle buttons, when set as required pressing P will transfer control to the next digit. When all the digits have been adjusted, press E to return to the `bRRLo` prompt from which `bRRH`, which defines the finishing point of the bargraph can be selected by pressing the \blacktriangle button. `bRRH` is adjusted in the same way as `bRRLo`. When set as required, pressing E twice will return the display to the `bRR` prompt in the configuration menu.

Note: `bRRLo` must be set lower than `bRRH`, incorrect setting is indicated by the bargraph scale flashing with a single bargraph segment activated.

6.8 Function of the P push-button: `[-P]`

When the indicator is in the display mode, operating the P push button will display the input current in milliamps, or the displayed value as a percentage of the difference between the displayed values at 4mA and 20mA inputs.

To check or change the function of the P push button select `[-P]` from the configuration menu and press P to reveal the current setting. Pressing the \blacktriangledown or \blacktriangle button will toggle the setting between `4-20` the current display in milliamps and `P%` the percentage display. When set as required press E to return to the `[-P]` prompt in the configuration menu.

6.9 Tare function: `LR-E`

The tare function is primarily intended for use with weighing system. When the indicator is in the display mode and the tare function is activated, pressing the E button for more than three seconds will zero the indicator's digital display and activate the tare annunciator. On the BA324G the bargraph remains linked to the digital display when the tare function is activated. Subsequent operation of the E push button for less than 3 seconds will return the indicator to the gross display and deactivate the tare annunciator.

To check or change the tare function select `LR-E` from the configuration menu and press P to reveal the current setting. Pressing the \blacktriangledown or \blacktriangle button will toggle the setting between `on` and `off`. When set as required press E to return to the `LR-E` prompt in the configuration menu.

6.10 Security code: `LoE`

Access to the instrument configuration menu may be protected by a four digit security code which

must be entered to gain access. New instruments are configured with the default security code `0000` which allows unrestricted access to all configuration functions.

To enter a new security code select `LoE` from the configuration menu and press P which will cause the indicator to display the existing security code with one digit flashing. The flashing digit can be adjusted using the \blacktriangledown or \blacktriangle push buttons, when set as required operating the P button will transfer control to the next digit. When all the digits have been adjusted press E to return to the `LoE` prompt in the configuration menu. The revised security code will be activated when the indicator is returned to the display mode. Please contact BEKA associates sales department if the security code is lost.

6.11 Reset to factory defaults: `r5Et`

This function enables the indicator and the lineariser to be quickly returned to the factory default configurations shown in sections 6.0 and 7.3

To reset the indicator or lineariser select `r5Et` from the configuration menu and press P , the indicator will display one of the reset options `LoF` or `LtRb`.

<code>LoF</code>	Resets the indicator to defaults
<code>LtRb</code>	Resets the lineariser to defaults

Using the \blacktriangledown or \blacktriangle push button select the required sub-function and press P . To prevent accidental resetting the request must be confirmed by entering `5urE`. Using the \blacktriangle button set the first flashing digit to 5 and press P to transfer control to the second digit which should be set to `u`. When `5urE` has been entered pressing the E button will reset the selected configuration menus and return the display to the `r5Et` function in the configuration menu.

6.12 Under and over-range

If the numerical display range of the indicator is exceeded, all the decimal points will flash as shown below:

	BA304G	BA324G
Underrange	-9.9.9.9	-9.9.9.9.9
Overrange	9.9.9.9	9.9.9.9.9

Although not guaranteed, most indicators will continue to function normally with an input current between 1.8mA and 4mA, at lower currents the instrument will display `LPLo` before it stops functioning.

Under or overrange of the BA324G bargraph is indicated by an activated arrow at the appropriate end of the bargraph and a flashing bargraph scale.

7. LINEARISER

A sixteen segment, seventeen break-point (0 to 16) lineariser may be selected in the $F_{un}E$ section of the configuration menu. The position of each break-point is fully adjustable so that the slope of the straight line between break-points can be set to compensate for input non-linearity, thus allowing the indicator to display a non-linear process variables in linear engineering units. Each break-point must occur at a current greater than the preceding break-point and less than the following break-point, in the range 3.8 to 21.0mA. If this requirement is not observed when configuring the lineariser the indicator will display FR, L and the configuration adjustment which produced the error message will be ignored. Fig 8 shows a typical linearised indicator characteristic.

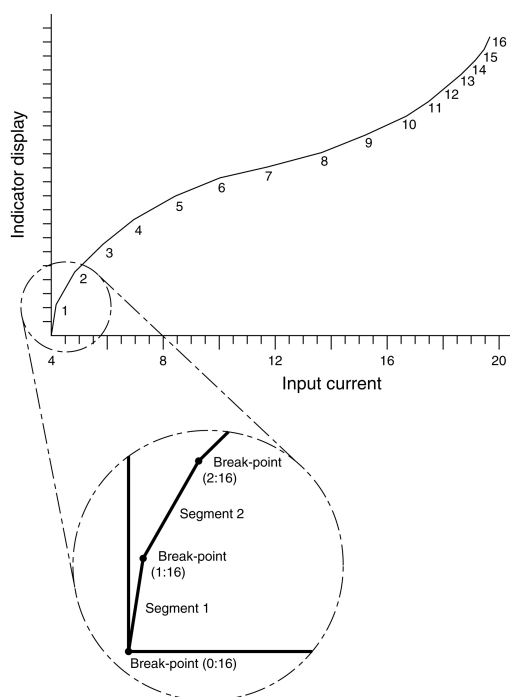

Fig 8 shows a typical linearising characteristic

Selecting L_{in} in the $F_{un}E$ section of the configuration menu activates the lineariser, this does not change the configuration menu shown in Fig 7, but the E_{RL} and $S_{E}E$ functions are extended as shown in Fig 9. As with a linear indicator, calibration of the lineariser may be performed with an external current source using the E_{RL} function, or with the internal reference using the $S_{E}E$ function.

The lineariser calibration is retained irrespective of how the indicator function $F_{un}E$ is subsequently changed. It is therefore possible to select and deselect the lineariser without having to reconfigure it each time.

The lineariser calibration may be reset to the factory default settings without changing the indicator configure using the $L_{E}Rb$ function described in section 6.11.

7.1 Lineariser calibration using an external current source.

This method allows direct calibration of the lineariser with an external current source and is the preferred method when traceability is required. If the exact system non-linearity is unknown, this method also allows direct calibration from the variable to be displayed. e.g. the output from a level sensor in an irregular tank may be displayed in linear volumetric units by filling the tank with known incremental volumes and calibrating the indicator to display the sum of the increments at each break-point.

The number of break-point required should first be entered using the R_{dd} and $d_{E}L$ functions. In both these sub-functions the indicator initially displays the current break-point and the total number of break-points being used as shown below.

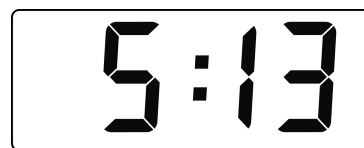

current total number
breakpoint of breakpoints

Display	Summary of function
R_{dd}	Add a break-point Adds a new break-point before the displayed break-point. The calibration of existing break-points is not changed, but the identification number of all subsequent break-points is increased by one.
$d_{E}L$	Remove a break-point Removes the displayed break-point and joins the preceding break-point to the following break-point with a straight line. The identification number of all subsequent break-points is decreased by one.

To add a break-point use the \blacktriangledown or \blacktriangle button to select E_{RL} from the configuration menu and press P which will result in the R_{dd} sub-function prompt being displayed. To enter the sub-function press P which will reveal the current break-point and the total number of break-points which have already been entered. When adding a break-point the insertion position can be selected using the \blacktriangledown and \blacktriangle push buttons followed by P push button to insert the additional break-point. In previously uncalibrated linearisers each new break-point should be added in front of the highest existing break-point, if this sequence is not followed a FR, L message will occur in the $P_{E}S$ function. See example in section 7.1.1.

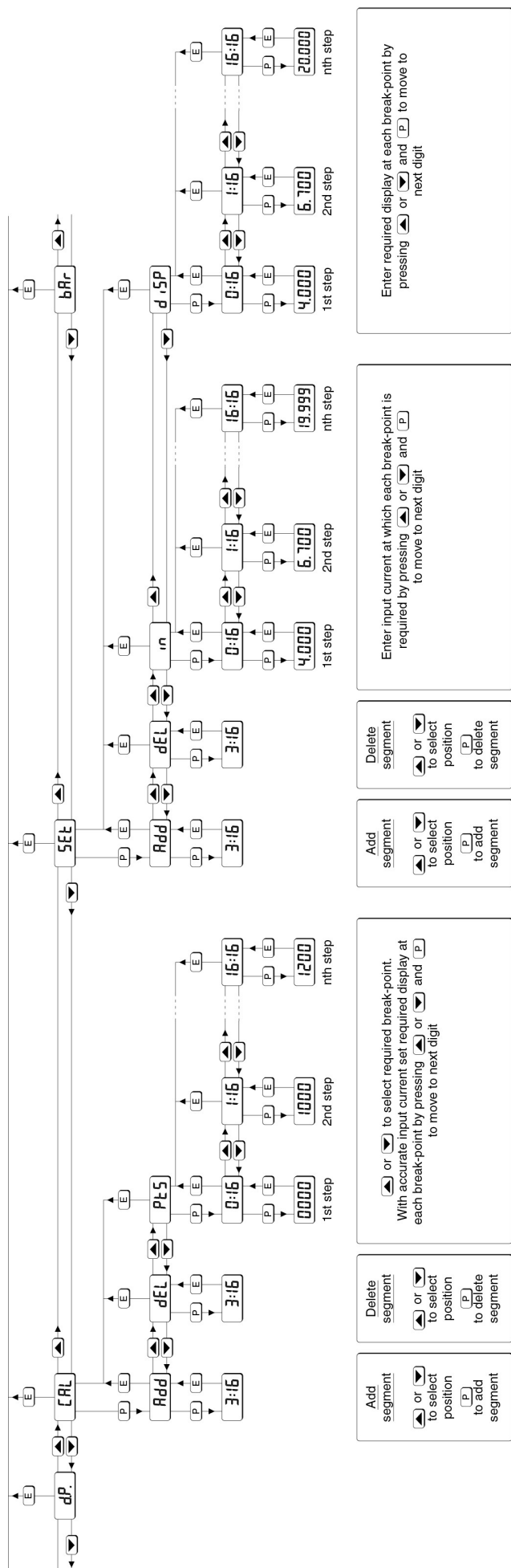

Calibration using external current source

Calibration using internal reference without the need for an external current source

Each break-point must occur at an input current greater than the preceding break-point and less than the following break-point, in the range 3.8 to 21.0 mA

Fig 9 Extension of CAL and SEt functions for lineariser configuration

The delete break-point sub-function dEL operates in exactly the same way as the Rdd sub-function described above. Once within the dEL sub-function each time the \square button is pressed a break-point is removed. When deleting a break-point from a calibrated indicator, the break-point to be deleted can be selected using the \blacktriangledown and \blacktriangle push buttons. The minimum number of break-points is 2, break-points $0:1$ and $1:1$.

When the required number of linearising break-points has been entered, return to the linearisation sub-menu by pressing \square . The indicator will display the Rdd or dEL prompt depending upon the last function used. Using the $PL5$ sub-function the input current at which each break-point occurs and the corresponding indicator display may now be defined.

Using the \blacktriangledown or \blacktriangle button select the $PL5$ function in the sub-menu and press \square to enter the function which will display the first break-point $0:n$, where n is the total number of linearising break-points entered - see Fig 9. The selected linearising break-point can be changed using the \blacktriangledown and \blacktriangle buttons. When the required linearising break-point has been selected set the indicator input current to the exact value at which the break-point is required and press \square^* . Using the \blacktriangledown and \blacktriangle buttons and the \square button to move between digits, enter the required indicator display at this break-point. When set as required, press the \square push button to enter the required indicator display and return to the sub-menu from which the next break-point can be selected.

When all the break-points have been calibrated pressing \square twice will return the indicator to the 'CAL' function in the configuration menu.

Note: * The indicator input current must be adjusted to the required value before the \square button is operated to enter the required indicator display.

Error message

If during calibration the indicator displays a FR, L error message the current at which the selected break-point is being set is not above the preceding break-point or is not below the following break-point.

7.1.1 Example

Adding break-points to a new indicator

When adding break-points to a new indicator, or to a lineariser following resetting to the factory defaults using the $LtRb$ function described in section 6.11, each additional break-point should be added before the highest existing breakpoint. The first additional break-point should be added before the default break-point $1:1$ which will result in a display of $1:2$. If more new break-points are

required, using the \blacktriangle button select the new highest break-point $2:2$ and add the second additional break-point by operating the \square push button which will result in a display of $2:3$. Repeat the sequence until the required number of break-points has been entered.

The input current and at which each break-point occurs and the corresponding indicator display may now be entered as described above.

7.2 Lineariser calibration using the internal reference.

The $5Et$ function enables the lineariser to be calibrated without the need for an accurate external current source. Throughout the calibration the indicator input current may be any value between 4 and 20mA.

The $5Et$ functions contains four sub-functions.

Display	Summary of function
Rdd	Add a break-point Adds a new break-point before the displayed break-point. The calibration of existing break-points is not changed, but the identification number of all subsequent break-point is increased by one.
dEL	Remove a break-point Removes the displayed break-point and joins the preceding segment to the following segment with a straight line. The identification number of all subsequent break-points is decreased by one.
$1:n$	Defines the current at which break-point occurs. Enables the required current at each break-point to be defined without having to input an accurate input current to the indicator.
$d, 5P$	Defines indicator display at break-point. Enables the indicator display at each break-point to be defined.

The number of break-point required should first be entered using the Rdd and dEL sub-functions. In both these sub-functions the indicator initially displays the current break-point and the total number of break-point being used as shown below.

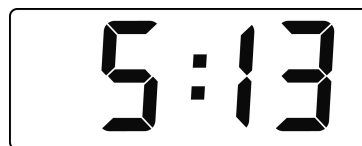

current total number
breakpoint of breakpoints

To add a break-point using the \blacktriangledown or \blacktriangle button select 5E \bar{L} from the configuration menu and press P which will result in the Rdd sub-function prompt being displayed. To enter the sub-function press P which will reveal the current break-point and the total number of break-points which have already been entered. When adding a break-point the insertion position can be selected using the \blacktriangledown and \blacktriangle push buttons followed by P push button to insert the additional break-point. In previously uncalibrated linearisers each new break-point should be added in front of the highest existing break-point, if this sequence is not followed a FR, L message will occur when the breakpoints are calibrated. See example in section 7.2.1.

The delete break-point, sub-function dEL operates in exactly the same way as the Rdd sub-function described above. Once within the dEL function each time the P button is pressed a break-point is removed. When deleting a break-point from a calibrated indicator, the break-point to be deleted can be selected using the \blacktriangledown and \blacktriangle push buttons. The minimum number of break-point is 2, break-points $\bar{L}:\bar{L}$ and $\bar{L}:\bar{L}$.

When the required number of linearising break-point has been entered, return to the linearisation sub-menu by pressing E . The indicator will display the Rdd or dEL prompt depending upon the last sub-function used. The indicator input current and corresponding indicator display at each break-point, which is the segment finishing point as shown in Fig 9, can now be entered using the $\bar{L}:\bar{L}$ and $\bar{L}:\bar{L}$ sub-functions.

Using the \blacktriangledown or \blacktriangle button select $\bar{L}:\bar{L}$ from the sub-menu and press P which will reveal the starting point for the first segment $\bar{L}:\bar{L}$, where \bar{L} is the total number of break-point entered. Press P and use the \blacktriangledown and \blacktriangle buttons and the P button to move between digits, to enter the input current in milliamps at which the first break-point is required, usually 4.000mA. When set as required, press E to return to the $\bar{L}:\bar{L}$ prompt from which the next break-point can be selected using the \blacktriangledown and \blacktriangle buttons. When the required break-point has been selected press P and enter the indicator input current at which this break-point is required using the \blacktriangledown and \blacktriangle buttons and the P button to move between digits. Repeat this procedure until the indicator input current at all the break-points has been defined and then return to the $\bar{L}:\bar{L}$ sub-function by pressing the E button.

The corresponding indicator display at each of the break-points can now be defined using the $\bar{L}:\bar{L}$ sub-function. Using the \blacktriangledown and \blacktriangle buttons select the $\bar{L}:\bar{L}$ sub-function and press P which will reveal the starting point for the first break-point $\bar{L}:\bar{L}$, where \bar{L} is the total number of break-points entered.

Press P and use the \blacktriangledown and \blacktriangle buttons and the P button to move between digits, to enter the required indicator display at the first break-point. When set as required, press E to return to the $\bar{L}:\bar{L}$ prompt from which the next break-point can be selected using the \blacktriangledown or \blacktriangle buttons. When the required break-point has been selected press P and set the required indicator display at this break-point.

Repeat this procedure until the indicator display at all the break-points has been defined and then return to the 5E \bar{L} function in the configuration menu by pressing the E button twice.

Error message

If during calibration the indicator displays a FR, L error message the current at which the selected break-point is being set is not above the proceeding break-point or is not below the following break-point.

7.2.1 Example

Adding break-points to a new indicator

When adding break-points to a new indicator, or to a lineariser following resetting to the factory defaults using the L \bar{L} Rb function described in section 6.11, each additional break-point should be added before the highest existing breakpoint. The first additional break-point should be added before the default break-point $\bar{L}:\bar{L}$ which will result in a display of $\bar{L}:\bar{L}$. If more new break-points are required, using the \blacktriangle button select the new highest break-point $\bar{L}:\bar{L}$ and add the second additional break-point by operating the P push button which will result in a display of $\bar{L}:\bar{L}$. Repeat the sequence until the required number of break-points has been entered.

7.3 Under and over-range

The lineariser does not change the under and over-range indication described in section 6.12. At input currents below that specified for the first break-point $\bar{L}:\bar{L}$, the indicator will continue to use the specified slope of the first segment.

At input currents above that specified for the last break-point $\bar{L}:\bar{L}$, the indicator will continue to use the slope specified for the last lineariser segment.

7.4 Lineariser default configuration

When the lineariser is reset to the factory defaults using the L \bar{L} Rb function described in section 6.11, the defaults conditions are:

	Indicator display			
	BA304G	BA324G		
First break-point	$\bar{L}:\bar{L}$	4mA	0.0	0.00
Second break-point	$\bar{L}:\bar{L}$	20mA	100.0	100.00

8. MAINTENANCE

8.1 Fault finding during commissioning

If an indicator fails to function during commissioning the following procedure should be followed:

Symptom	Cause	Solution
No display	Incorrect wiring	Check wiring There should be 0.6 to 1.2V between terminals 1 & 3 with terminal 1 positive. With an optional backlight loop powered, there should be 3.4 to 5V between terminals 3 & 12 with terminal 12 positive.
No display 0V between terminals 1 & 3.	Incorrect wiring or no power supply	Check supply voltage and voltage drop caused by all the instruments in the loop.
All decimal points flashing.	Overrange or underrange if -ve sign is displayed.	Recalibrate the numerical display.
Unstable display	4/20mA input is noisy.	Eliminate ripple on 4/20mA power supply and/or decrease indicator resolution.
Unable to enter configuration menu.	Incorrect security code entered.	Enter correct security code, or contact BEKA if the code has been lost.

8.2 Fault finding after commissioning

ENSURE PLANT SAFETY BEFORE STARTING MAINTENANCE

Live maintenance is permitted on intrinsically safe equipment installed in a gas hazardous area, but only certified test equipment should be used unless a gas clearance certificate is available.

If an indicator fails after it has been functioning correctly, follow the procedure shown in section 8.1. If this does not reveal the cause of the fault, it is recommended that the instrument is replaced. This can be done without disconnecting power, but while the indicator is disconnected the 4/20mA loop will be open circuit.

8.3 Servicing

All BA304G and BA324G loop powered indicators are interchangeable if the required optional backlight and alarms are fitted. A single spare instrument may quickly be recalibrated to replace any instrument that is damaged or fails. No attempt should be made to repair instruments at component level.

We recommend that faulty instruments are returned to BEKA associates or to your local BEKA agent for repair.

8.4 Routine maintenance

The mechanical condition of the instrument and electrical calibration should be regularly checked. The interval between inspections depends upon environmental conditions. We recommend that initially instrument calibration should be checked annually.

8.5 Guarantee

Indicators which fail within the guarantee period should be returned to BEKA associates or our local agent. It is helpful if a brief description of the fault symptoms is provided.

8.6 Customer comments

BEKA associates is always pleased to receive comments from customers about our products and services. All communications are acknowledged and whenever possible, suggestions are implemented.

9. ACCESSORIES

9.1 Units measurement & instrument identification.

New BA304G and BA324G indicators are supplied with a printed scale card showing the units of measurement and tag information specified when the instrument was ordered. If this information was not supplied a blank scale card will be supplied which can easily be marked with a dry transfer or a permanent marker.

Custom printed scale cards are available as accessories and may be easily fitted as shown in section 5.4 of this manual.

Both indicators can also be supplied with a blank or custom laser engraved stainless steel legend plate - see Fig 5. The plate, which after installation is visible from the front of the instrument, is supplied loose with two fixing screws for securing it to the rear of the instrument's back-box. This plate can typically accommodate:

- 1 row of 5 alphanumeric characters 10mm high
- or 1 row of 6 alphanumeric characters 7mm high
- or 2 rows of 10 alphanumeric characters 5mm high

9.2 Display backlight

The BA304G and BA324G loop powered indicators can be supplied with a factory fitted backlight that may be loop or separately powered.

When loop powered the backlight produces green background illumination enabling the display to be read at night or in poor lighting conditions. No additional power supply, intrinsic safety interface or field wiring are required, but the indicator voltage drop is increased. When separately powered the backlight is brighter, but an additional intrinsic safety interface and field wiring are required.

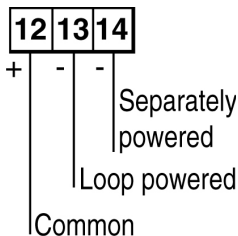

Fig 10 Terminals for optional backlight

9.2.1 Loop powering the backlight

The backlight is loop powered by connecting it in series with the indicator's 4/20mA input as shown in Fig 11, which increases the maximum indicator voltage drop from 1.2 to 5V.

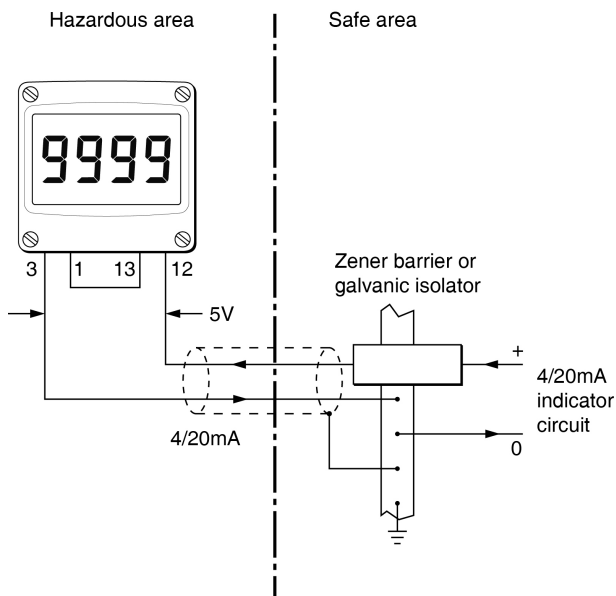

Fig 11 Backlight loop powered

The input intrinsic safety parameters of the combined indicator and backlight are the same as for the indicator alone. The EC-Type Examination Certificate states that for intrinsic safety considerations, under fault conditions the output voltage, current and power of the combined indicator and backlight terminals 12 & 3 will not exceed those specified by clause 5.7 of EN 60079-11 for *simple apparatus*, which simplifies system design and documentation.

Providing the increased voltage drop can be tolerated the intrinsic safety and system design described in sections 3 and 4 of this manual remain valid with the backlight loop powered.

9.2.2 Separately powering the backlight

The optional backlight may also be powered from a separate safe area power supply via an intrinsically safe interface as shown in Fig 12.

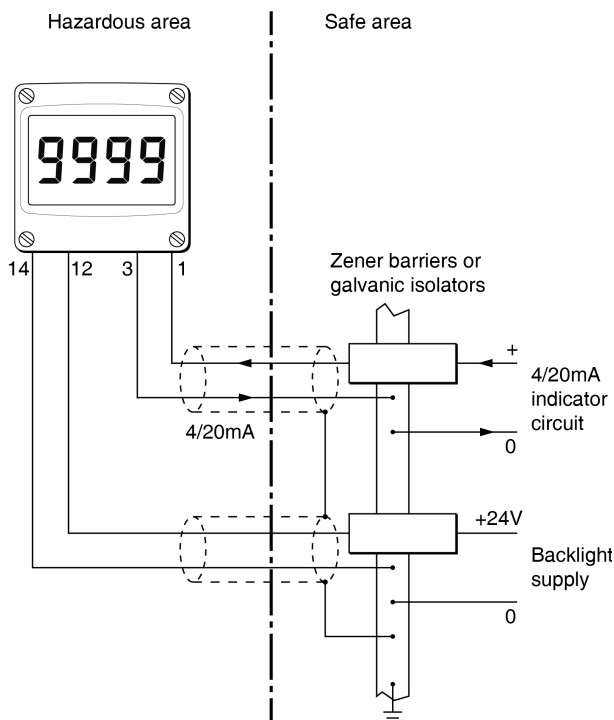

Fig 12 Backlight separately powered

When separately powered the backlight draws a constant current providing the supply is equal to or greater the minimum specified voltage. Below this supply voltage the backlight continues to function but with reduced brilliance.

	Current	Minimum voltage
BA304G & BA324G	34.7mA	11V

Any certified Zener barrier or galvanic isolator may be used, providing the output parameters do not exceed:

$$\begin{aligned}
 U_o &= 30V \text{ dc} \\
 I_o &= 200mA \\
 P_o &= 0.84W
 \end{aligned}$$

The internal capacitance C_i between terminals 12 & 14 should be subtracted from C_o of the intrinsically safe interface powering the backlight to determine the maximum permissible cable capacitance.

$$\begin{aligned}
 C_i &= 3.3nF \\
 I_i &= 0.008mH (0.01mH)
 \end{aligned}$$

9.3 Alarms

CAUTION

These alarms outputs should not be used for critical safety applications such as an emergency shut down system.

Both models can be supplied with factory fitted dual solid state, single pole alarm outputs. Each alarm output may be independently conditioned as a high or low alarm with a normally open or normally closed output in the non-alarm condition.

When the 4/20mA current powering the indicator is removed both alarm outputs will open irrespective of configuration. The open circuit condition should therefore be chosen as the alarm condition when designing an alarm system. Fig 13 illustrates the conditions available and shows which are fail safe.

When an alarm occurs an alarm annunciator on the indicator front panel is activated and if required the numerical display can alternate between the measured value and the alarm channel identification $RLr1$ or $RLr2$.

CAUTION

The alarms are activated by the indicator's numerical display. Use of the Tare Function $LRrE$ will change the numerical display, the alarms will continue to function at the original displayed value, but this will correspond to a different input current.

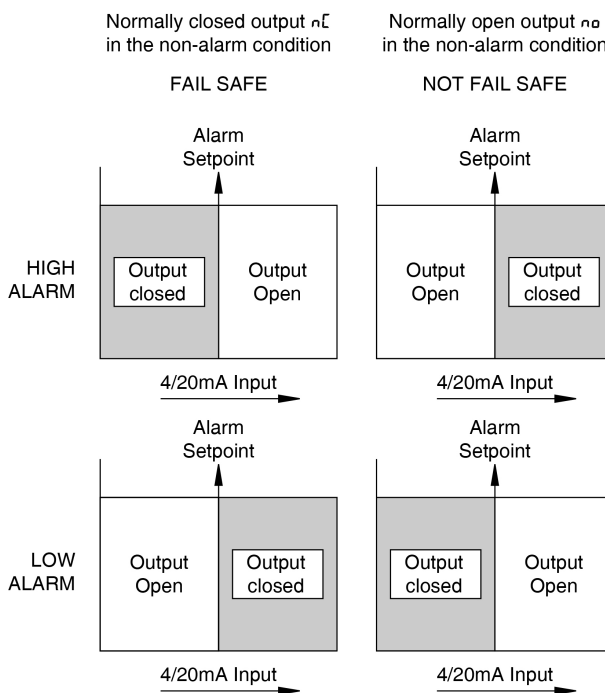

Fig 13 Alarm outputs

Configurable functions for each alarm include adjustable setpoint, hysteresis, alarm delay and alarm accept.

9.3.1 Solid state output

Each alarm has a galvanically isolated single pole solid state switch output which as shown in Fig 14. The output is polarised and current will only flow in one direction.

$$\begin{aligned} R_{on} &= \text{less than } 5\Omega + 0.7V \\ R_{off} &= \text{greater than } 1M\Omega \end{aligned}$$

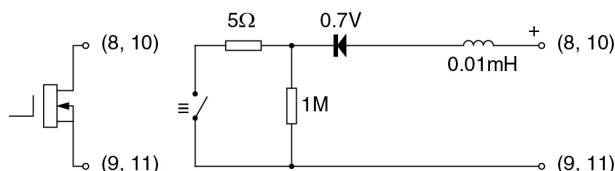

Fig 14 Equivalent circuit of each alarm output

9.3.2 Intrinsic safety

Each alarm output is a separate galvanically isolated intrinsically safe circuit. The EC-Type Examination Certificate states that for intrinsic safety considerations, under fault conditions the output voltage, current and power at terminals 8 & 9 and 10 & 11 will not exceed those specified by clause 5.7 of EN 60079-11 for *simple apparatus*. This simplifies system documentation and allows the alarm output terminals 8 & 9 and 10 & 11 to be connected to almost any intrinsically safe circuit protected by a Zener barrier or galvanic isolator providing the output parameters of the circuit do not exceed:

$$\begin{aligned} U_o &= 30V \\ I_o &= 200mA \\ P_o &= 0.84W \end{aligned}$$

The maximum equivalent capacitance and inductance between each set of alarm terminals is:

$$\begin{aligned} C_i &= 0 \\ L_i &= 0.008mH (0.01mH) \end{aligned}$$

The maximum allowable cable capacitance will be the same as that permitted by the certificate for the device powering the alarm circuit, such as the solenoid driver or switch transfer galvanic isolators shown in Fig 15. The maximum permitted cable inductance will be that specified for the device powering the alarm circuit less 0.01mH.

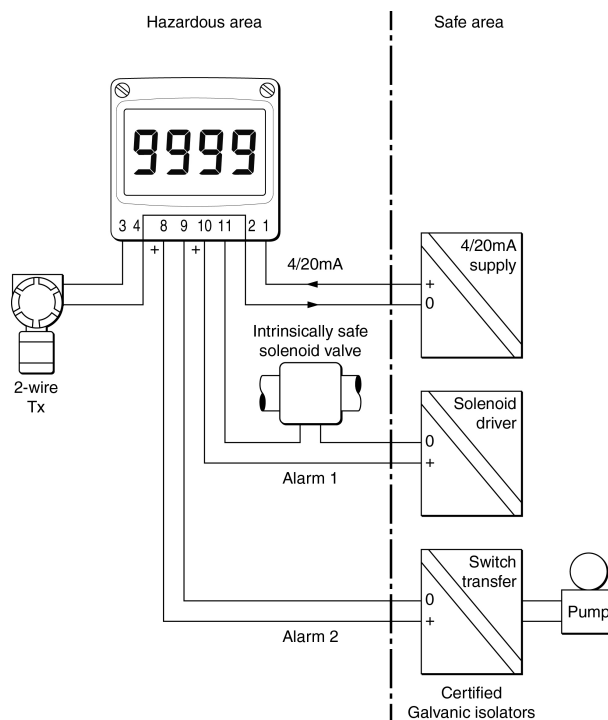

Fig 15 Typical alarm application
(Shown without recommended screened cables)

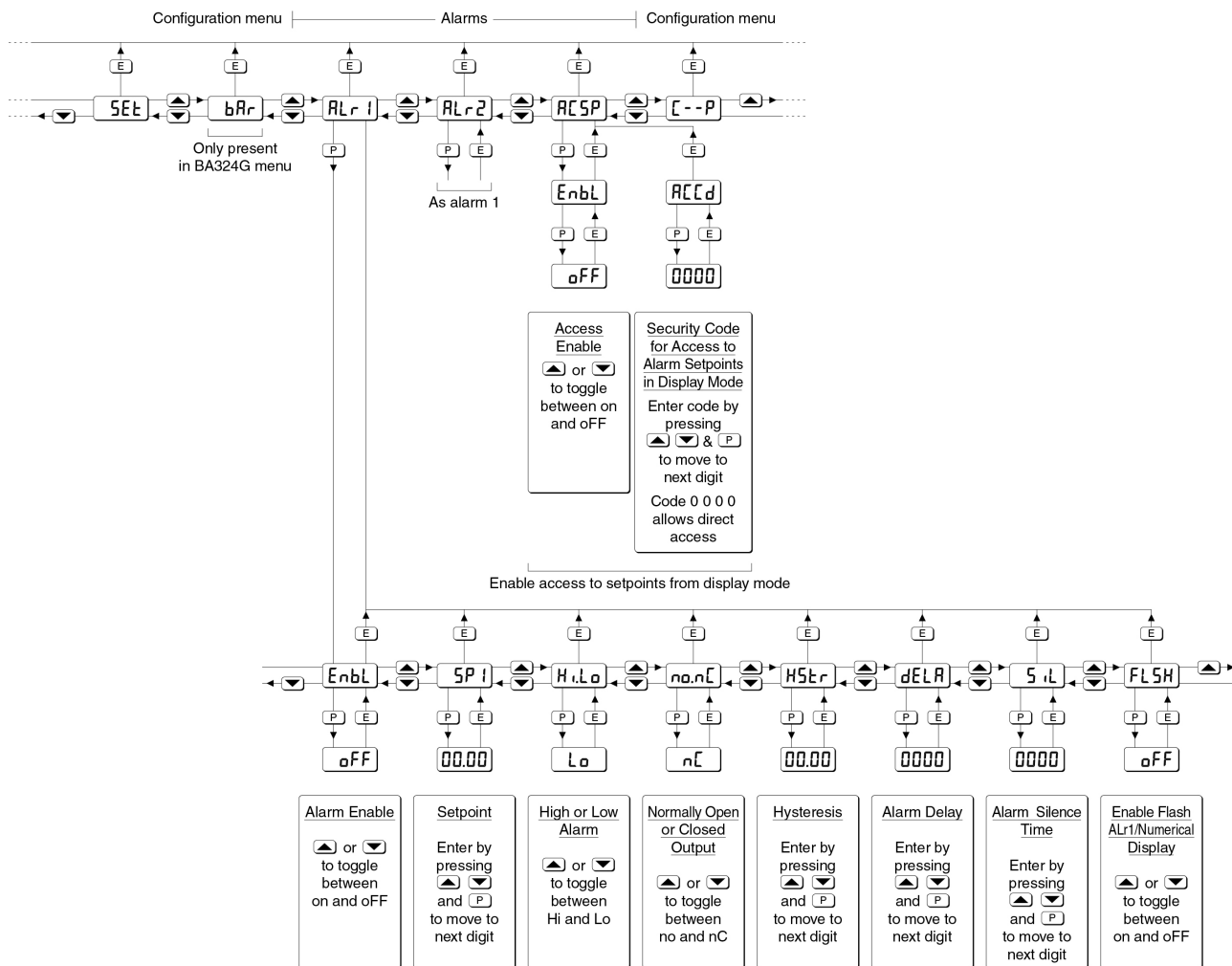

Fig 16 Alarm Configuration Functions in Configuration Menu

9.3.3 Configuration and adjustment

When optional alarms are fitted to a loop powered indicator the configuration menu is extended as shown in Fig 16. The additional functions appear between the SEt and the $[-P]$ functions for the BA304G and between bRr and $[-P]$ for the BA324G indicator. For simplicity, Fig 16 only shows the additional functions for alarm 1, but alarm 2 has identical functions.

The following table summaries each of the alarm configuration functions and includes a cross reference to more detailed information. Again only the functions on Alarm 1 are listed, but alarm 2 has identical facilities.

Summary of alarm configuration functions

Display	Summary of function
EnbL	Alarm enable Enables or disables the alarm without changing the alarm parameters. See section 9.3.4
SP 1	Alarm setpoint 1 Adjusts the alarm setpoint. The alarm is activated when the indicator display equals the setpoint. See section 9.3.5
H.Lo	Alarm function Defines the alarm function as High or Low. See section 9.3.6
no.nC	Normally open or normally closed output Sets the alarm output open or closed in the non-alarm condition. See section 9.3.7
HSEr	Hysteresis Adjusts the alarm hysteresis. See section 9.3.8
dELR	Alarm delay time Introduces adjustable delay between the display equalling the setpoint and the alarm output being activated. See section 9.3.9
S.L	Alarm silence time Defines the time that the alarm output remains in the non-alarm condition following acceptance of an alarm. See section 9.3.10
FLSH	Flash display when alarm occurs When enabled, alternates the numerical display between process value and alarm reference, R_{Lr1} or R_{Lr2} , when an alarm output is activated. See section 9.3.11
RCSP	Access setpoint Sub-menu which enables direct access to the alarm setpoints from the indicator display mode, and defines a separate security code. See section 9.3.12

9.3.4 Alarm enable: E_{nbl}

This function allows each alarm to be enabled or disabled without altering any of the alarm parameters. To enable or disable the alarm select E_{nbl} from the alarm menu and press P which will reveal the current setting on or off . The function can be changed by pressing the \blacktriangledown or \blacktriangle button followed by the E button to return to the alarm menu.

9.3.5 Setpoint adjustment: $SP1$ and $SP2$

The setpoint of each alarm may be positioned anywhere in the numerical display of the indicator providing that this corresponds to an input current between 3.8 and 20.2mA. e.g. If the indicator has been calibrated to display 0 with 4mA input and 10000 with 20mA input, the two alarm setpoints may be positioned anywhere between -125 and 10125.

To adjust the setpoint select $SP1$ or $SP2$ from the alarm configuration menu and press P which will reveal the existing alarm setpoint. The flashing digit of the setpoint can be adjusted using the \blacktriangledown and \blacktriangle push-buttons, and the P button to move control to the next digit. When the required setpoint has been entered press E to return to the alarm configuration menu.

The alarm setpoints may also be adjusted when the indicator is in the display mode, see section 9.3.12.

9.3.6 Alarm function: $H.La$

Each alarm can be independently conditioned as a high alarm or as a low alarm. To check or change the alarm function select $H.La$ from the alarm menu and press P to reveal the current setting. The function can be changed by pressing the \blacktriangledown or \blacktriangle button followed by the E button to return to the alarm menu.

9.3.7 Alarm output status: no,nc

Configures the solid state alarm output to be open 'no' or to be closed nc in the non-alarm condition. When deciding which is required, care should be taken to ensure that the alarm output is fail safe as illustrated in Fig 13.

no Alarm output open in non-alarm condition

nc Alarm output closed in non-alarm condition

CAUTION

When the 4/20mA supply is removed from the loop powered indicator, both alarm outputs will open irrespective of conditioning. Therefore for fail safe operation both alarm outputs should be conditioned to be open in the alarm condition nc .

To check or change the alarm output status, select no,nc from the alarm configuration menu and press P to reveal the setting. The function may be changed by pressing the \blacktriangledown or \blacktriangle button followed by the E button to return to the alarm configuration menu.

9.3.8 Hysteresis: $H5Lr$

Hysteresis is shown in the units that the indicator has been calibrated to display.

To adjust the hysteresis select $H5Lr$ from the alarm menu and press P which will reveal the existing figure. The flashing digit can be adjusted using the \blacktriangledown and \blacktriangle push-buttons, and the P button will move control to the next digit. When the required hysteresis has been entered press E to return to the alarm configuration menu.

e.g. An indicator calibrated to display 0 to 10000, with a high alarm set at 9000 and hysteresis of 200 will perform as follows:

The high alarm will be activated when increasing indicator display equals 9000, but will not reset until the indicator display falls below 8800.

9.3.9 Alarm delay: $dELR$

This function delays activation of the alarm output for an adjustable time following the alarm condition occurring. The delay can be set in 1 second increments between 0 and 3600 seconds. If a delay is not required zero should be entered. To adjust the delay select $dELR$ from the alarm configuration menu and press P which will reveal the existing delay. The flashing digit of the delay can be adjusted using the \blacktriangledown and \blacktriangle push buttons, and the P button to move control to the other digits. When the required delay has been entered press E to return to the alarm menu.

e.g. An indicator with a high alarm set at 9000 and an alarm delay of 30 seconds will perform as follows:

The alarm annunciator will start to flash when an increasing indicator display equals 9000, but the alarm output will not be activated until the alarm condition has existed continuously for 30 seconds. When the alarm output is activated, the alarm annunciator will stop flashing and be permanently activated.

If the $FL5H$ function, which flashes the indicator display when an alarm occurs, has been enabled, it will not start to function until the alarm output is activated.

See section 9.3.11

9.3.10 Alarm silence time: 5, L

This function is primarily intended for use in small installations where the alarm output directly operates an alarm annunciator such as a sounder or beacon. When the alarm silence time, which is adjustable between 0 and 3600 seconds in 1 second increments, is set to any figure other than zero, the **[P]** push button becomes an alarm accept button. After an alarm has occurred, operating the **[P]** button will cause the alarm output to revert to the non-alarm condition for the programmed alarm silence time. If the alarm condition still exists at the end of the silence time, the alarm output will be reactivated. During the silence time the indicator alarm annunciator will flash until the silence time expires or the alarm is cleared.

If the *FLASH* function, which flashes the indicator display when an alarm occurs has been enabled, it will only function when the alarm output is activated, not during the silence time. See section 9.3.11

To adjust the alarm silence time select 5, L from the alarm configuration menu and press **[P]** which will reveal the existing silence time. The flashing digit of the silence time can be adjusted using the **[▼]** and **[▲]** push buttons, and the **[P]** button to move control to the other digits. When the required silence time has been entered press **[E]** to return to the alarm menu.

9.3.11 Flash display when alarm occurs: FLASH

In addition to the two alarm annunciators on the top left hand corner of the indicator display which show the status of both alarms, this function provides an even more conspicuous indication that an alarm condition has occurred.

When enabled, the function alternates the indicator display between the numerical value and the alarm reference, *RLR1* or *RLR2*, when the alarm output is activated. If both alarm outputs are activated, the alarm references are displayed in sequence.

To enable or disable the function select *FLASH* from the alarm menu and press **[P]** which will reveal the current setting *on* or *off*. The function can be changed by pressing the **[▼]** or **[▲]** button followed by the **[E]** button to return to the alarm menu.

9.3.12 Access setpoint in display mode: R5P

This function enables a separate menu providing access to the alarm setpoints from the display mode by simultaneously operating the **[P]** and **[▲]** push buttons. An operator can therefore adjust the alarm setpoints without having access to the indicator configuration menu. Protection against accidental adjustment of the setpoints when the indicator is in the display mode is provided by a separate security code.

This direct setpoint access menu is enabled and the separate security code entered from the *R5P* function in the alarm configuration menu as shown in Fig 16. To change the menu parameters select *R5P* from the configuration menu and press **[P]** which will display the enable prompt *ENBL*. Press **[P]** again to reveal if the direct access menu is *on* or *off*. The **[▼]** or **[▲]** button will toggle the display between the two conditions.

If *off* is selected, the operator will not have access to the setpoints from the display mode. Return to the *R5P* prompt in the main menu by pressing **[E]** twice.

If *on* is selected, the operator will have direct access to the alarm setpoints from the display mode via a separate optional security code. To define this four digit security code press **[P]** to return to the *ENBL* prompt followed by the **[▼]** or **[▲]** button to select the access code prompt *RCd*. Pressing **[P]** will reveal the current security code. Each digit of the code may be changed by operating the **[▼]** and **[▲]** push buttons, and the **[P]** button to move control to the next digit. When the required code has been entered, press **[E]** twice to return to the *R5P* prompt in the configuration menu.

Default code 0000 will disable the security code allowing direct access to the setpoints in the display mode by pressing the **[P]** and **[▲]** buttons simultaneously. Unless otherwise requested new instruments with alarms are supplied with this function disabled and the security code set to 0000.

9.3.13 Adjusting alarm setpoints from the display mode.

Access to the alarm setpoints from the indicator display mode is obtained by operating the **[P]** and **[▲]** push buttons simultaneously as shown in Fig 17. If the setpoints are not protected by a security code the alarm setpoint prompt *SP1* will be displayed. If the setpoints are protected by a security code, *Code* will be displayed first. Pressing **[P]** again will enable the alarm security code to be entered digit by digit using the **[▼]** and **[▲]** buttons to change the flashing digit, and the **[P]** push button to move control to the next digit. If the correct code is entered pressing **[E]** will cause alarm setpoint prompt *SP1* to be displayed. Pressing the **[▼]** or **[▲]** button will toggle the display between the two alarm setpoint prompts *SP1* and *SP2*.

If an incorrect security code is entered, or a button is not pressed within twenty seconds, the indicator will automatically return to the display mode.

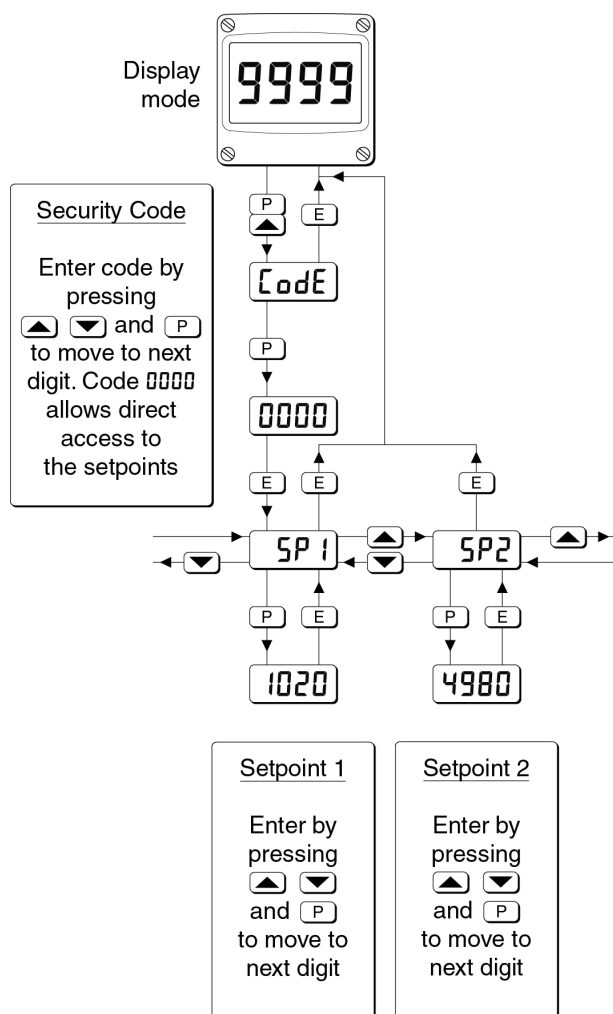

Fig 17 Setpoint adjustment from the display mode

To adjust an alarm setpoint select $SP1$ or $SP2$ and press **P** which will reveal the current setting. Each digit of the setpoint may be adjusted using the **▼** and **▲** push buttons, and the **P** button to move control to the next digit. When the required setpoint has been entered, pressing **E** will return the display to the $SP1$ or $SP2$ prompt from which the other setpoint may be selected, or the indicator may be returned to the display mode by pressing **E** again.

Note: With the indicator in the display mode, direct access to the alarm setpoints is only available when the ACSP menu is enabled - see section 9.3.12

9.3.14 Displaying setpoints on BA324G bargraph

One of the selectable bargraph formats $RLr5P$ allows a low or a high setpoint plus the displayed value to be represented, or a low and a high setpoint plus the displayed value to be represented by the bargraph as shown in Fig 18.

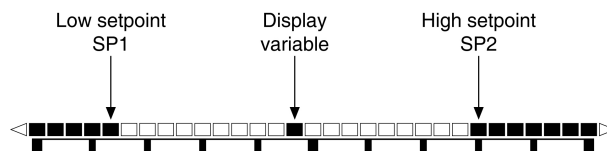

Fig 18 Displayed value and setpoints on bargraph

The bargraph area below the low alarm setpoint and the area above the high alarm setpoint are activated. The displayed variable is represented by an activated bar which moves between these low and high alarm setpoints.

When the activated bar representing the displayed variable is adjacent to the area representing the low or high alarm setpoints, the bar flashes. When a displayed variable equals the low or high alarm the complete bargraph representing the activated alarm flashes irrespective of whether the alarm output has been delayed or cleared.

For this function to operate $SP1$ must be conditioned as a low alarm and $SP2$ as a high alarm; $SP1$ must always be less than $SP2$. Incorrect configuration is shown by a flashing bargraph scale with no activated bars.

9.4 Pipe mounting kits

Two alternative stainless steel pipe mounting kits are available for securing an indicator to a horizontal or vertical pipe.

The BA392G Pipe Mounting Kit employs a single hose clip which is adequate for many applications. For use in severe environments where maximum rigidity is required, the BA393G Pipe Mounting Kit employs two stainless steel bolts.

Detailed assembly instructions are supplied with each pipe mounting kit.

9.5 Back-box terminal assembly

If it is necessary to terminate the field wiring prior to the installation of the indicator display, a back-box terminal assembly is available as a factory fitted option. This accessory includes terminals for the field wiring and diodes which maintain the continuity of the 4/20mA loop when the indicator display is unplugged.

When the indicator display is unplugged from the back-box, the voltage drop introduced into the 4/20mA loop by the instrument increases to 5V. If an optional backlight is fitted and connected for loop powering, the voltage drop increases to 11.5V when the indicator display is unplugged. This voltage drop can be reduced to 7.5V by connecting a 7.5V Zener diode with a minimum rating of 1.3W at 25°C (BZX85 or 1N5343) between terminals 3 (diode cathode) and 12.(diode anode).

The optional terminal assembly also includes additional terminals which may be used for linking cable screens and two terminals connected to the carbon loaded GRP enclosure. If the enclosure is not fixed to an earthed structure, one of these terminals or the earth terminal on the bonding plate should be connected to the plant's potential equalising conductor.

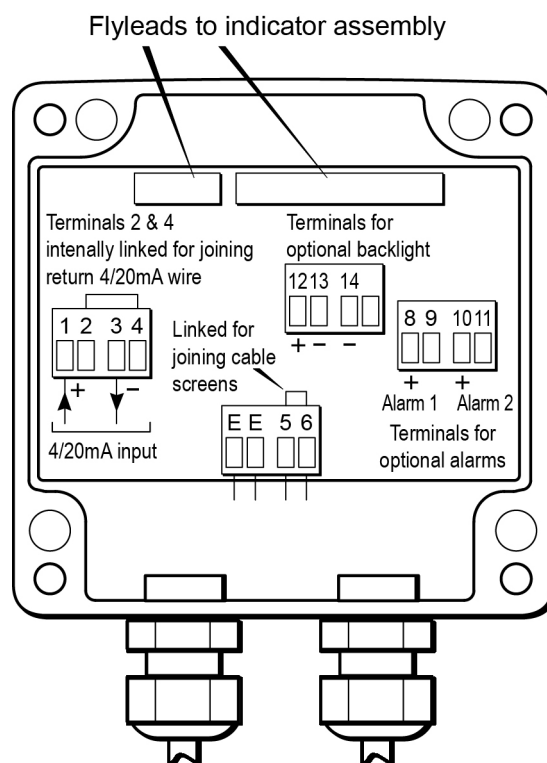

Fig 19 Optional back-box terminal assembly

APPENDIX 1

ATEX Dust Certification

A1.0 ATEX dust certification

In addition to ATEX certification permitting installation in explosive gas atmospheres which is described in the main section of this instruction manual, the BA304G and the BA324G also have ATEX dust certification.

A1.1 Zones, and Maximum Surface Temperature

Both indicators have been certified Ex ia IIIC T80°C Da IP66. When connected to a suitable system they may be installed in:

- Zone 20 explosive atmosphere in the form of a cloud of combustible dust in air is continuously present, or for long periods or frequently.
- Zone 21 explosive atmosphere in the form of a cloud of combustible dust in air is likely to occur occasionally in normal operation.
- Zone 22 explosive atmosphere in the form of a cloud of combustible dust in air is not likely to occur in normal operation, but if it does occur, will only persist for a short period.

Be used with dust in subdivisions:

- IIIA combustible flyings
- IIIB non-conductive dust
- IIIC conductive dust

Having a Minimum Ignition Temperature of:

- Dust cloud 120°C
- Dust layer on indicator up to 5mm thick 155°C
- Dust layer on indicator over 5mm thick. Refer to EN 60079-14

At an ambient temperature between -40 and +70°C

A1.2 Installation and maintenance

The installation requirement described in this manual for potentially gas explosive atmospheres also apply when the indicators are installed in a dust explosive atmosphere.

The instrument assembly should only be removed from the enclosure back-box when dust can not enter the instrument enclosure. Before replacing the instrument assembly the sealing gasket should be inspected to ensure that it is undamaged and free from foreign bodies.

It is good practice to prevent dust accumulating on the indicator enclosure. If this can not be avoided, care should be taken to ensure that the layer thickness does not exceed 5mm for dusts having a minimum ignition temperature of 155°C.

APPENDIX 2

IECEX certification

A2.0 The IECEX Certification Scheme

IECEX is a global certification scheme for explosion protected products which aims to harmonise international certification standards. For additional information about the IECEX certification scheme and to view the BEKA associate certificates, please visit www.iecex.com

A2.1 IECEX Certificate of Conformity

The BA304G and the BA324G loop powered indicators and the optional accessories have been issued with an IECEX Certificate of Conformity number IECEX ITS 11.0014X which specifies the following certification codes:

Ex ia IIC T5 Ga
Ex ia IIIC T80°C Da IP66
Ta = -40°C to 70°C

The specified IECEX gas and dust intrinsic safety parameters are identical to the ATEX safety parameters described in the main section and Appendix 1 of this manual.

The IECEX certificate may be downloaded from www.beka.co.uk, www.iecex.com or requested from the BEKA sales office.

A2.2 Installation

The IECEX and ATEX certificates specify identical safety parameters and installation requirements for both approvals as defined by IEC 60079-14. The ATEX installation requirements specified in the main section and Appendix 1 of this manual may therefore be used for IECEX installations, but the local code of practice should also be consulted.