

Data Sheet

# SCHISCHEK INBIN-P

Pressure switches 5 Pa ... 5.000 Pa



Supplied by

**247able.com**

Call us on +44 (0)118 916 9420 | Email [info@247able.com](mailto:info@247able.com)

# InBin-P Pressure switches 5 Pa ... 5.000 Pa

Electrical binary pressure/differential pressure switches  
5 Pa...100 Pa with adjustable switch activation delay  
24 VAC/DC supply voltage, output potential free switching contact

|                    |
|--------------------|
| InBin - P- ...     |
| InBin - P- ... - 2 |
| InBin - ... - CT   |
| InBin - ... - OCT  |
| InBin - ... - VA   |
| InBin - ... - OVA  |

Subject to change!

**Compact. Easy installation. Universal. Cost effective. Safe.**

| Type                | Switch   | Supply    | Range        | min. Setting | max. Pressure | Activation delay | Output switch          | Wiring diagram             |        |
|---------------------|--|-----------|--------------|--------------|---------------|------------------|------------------------|----------------------------|--------|
| InBin- P- 100       | Pressure   | 24 VAC/DC | 0... 100 Pa  | 5 Pa         | 5.000 Pa      | 0...240 s        | potential free contact | SB 1.0                     |        |
| InBin- P- 500       | Pressure   | 24 VAC/DC | 0... 500 Pa  | 25 Pa        | 5.000 Pa      | –                | potential free contact | SB 1.0                     |        |
| InBin- P-5000       | Pressure   | 24 VAC/DC | 0...5.000 Pa | 250 Pa       | 50.000 Pa     | –                | potential free contact | SB 1.0                     |        |
| InBin- P- ... - 2   | Types ...P-500 und ...P-5000 as above with additional switching output   |           |              |              |               |                  |                        | 2 × potential free contact | SB 1.0 |
| InBin- P- ... - CT  | Types as above with aluminium housing and seawater resistant coating (cable glands M16 brass nickel-plated, screws in stainless steel)   |           |              |              |               |                  |                        |                            |        |
| InBin- P- ... - OCT | Types as above, offshore version with aluminium housing and seawater resistant coating (stainless steel tubes for clamping ring connection, cable glands M20 brass nickel-plated, screws in stainless steel) |           |              |              |               |                  |                        |                            |        |
| InBin- P- ... - VA  | Types as above with stainless steel housing for aggressive ambient (cable glands M20 brass nickel-plated, screws in stainless steel)   |           |              |              |               |                  |                        |                            |        |
| InBin- P- ... - OVA | Types as above, offshore version with stainless steel housing for aggressive ambient (tubes for clamping ring connection and screws in stainless steel, cable glands M20 brass nickel-plated)                |           |              |              |               |                  |                        |                            |        |

**Product views and applications** Figures ...Bin-P-...-2



**Description**

The InBin-P-... pressure switch generation from 5...5000 Pa (acc. to type) is a revolution for differential pressure switches in HVAC systems, in chemical, pharmaceutical, industrial and offshore/onshore plants. IP66 protection, small dimensions, universal functions and technical data guarantee safe operation even under difficult environmental conditions. All pressure switches are programmable on site without any additional tools. The switching points are scalable within the maximum ranges. The integrated display is for parametrisation and an actual value indication at working mode (can be switched off as needed).  
...Bin-P-...-2 switches are equipped with an additional switching output (2-stage), which can be parametrised independently.  
...Bin-P-...-OCT and ...-OVA offshore versions are equipped with stainless steel tubing Ø 6 mm.

**Highlights**

- ▶ For industrial use
- ▶ Power supply 24 VAC/DC
- ▶ Potential free switching contact output
- ▶ Adjustable switching threshold, hysteresis and start-up bypass time
- ▶ Adjustable switch activation delay (acc. to type)
- ▶ Integrated terminal box
- ▶ Optional second switching output (acc. to type)
- ▶ Display with backlight, can be switched off
- ▶ Password locking
- ▶ Down to -20 °C ambient temperature applicable
- ▶ Compact design and small dimension
- ▶ Robust aluminium housing (optional with seawater resistant coating) or in stainless steel
- ▶ IP66 protection
- ▶ Offshore versions with pressure tube connection for clamping ring Ø 6 mm

| Technical data                       | ...-P-100  | ...-P-500                           | ...-P-5000                          |
|--------------------------------------|--|-------------------------------------|-------------------------------------|
| Supply voltage, frequency            | 24 VAC/DC $\pm$ 20 % (19,2...28,8 VAC/DC), 50/60 Hz  |                                     |                                     |
| Current, power consumption           | 150 mA, ~ 4 W, internal fuse 500 mA, without bracket, not removable  |                                     |                                     |
| Galvanic isolation                   | Supply for relay output min. 1,5 kV  |                                     |                                     |
| Electrical connection                | Terminals 0,14...2,5 mm <sup>2</sup> at integrated terminal box, stripping length 9 mm, torque 0,4...0,5 Nm, equipotential bonding 4 mm <sup>2</sup>   |                                     |                                     |
| Cable glands                         | 2 x M16 x 1,5 mm, for cable diameter ~ $\varnothing$ 5...9 mm  |                                     |                                     |
| Cable glands ...-CT                  | 2 x M16 x 1,5 mm, brass nickel-plated, for cable diameter ~ $\varnothing$ 6...10 mm  |                                     |                                     |
| ...-VA, ...-OCT, ...-OVA             | 2 x M20 x 1,5 mm, brass nickel-plated, for cable diameter ~ $\varnothing$ 6...13 mm  |                                     |                                     |
| Protection class                     | Class I (grounded)   |                                     |                                     |
| Display                              | LC-Display, backlit, for configuration, user guidance, parameter and actual value indication. Status indicator via LEDs  |                                     |                                     |
| Control elements                     | 3 buttons for configuration  |                                     |                                     |
| Housing material                     | Aluminium die-cast housing, coated. Optional with seawater resistant coating (...-CT/...-OCT) or stainless steel housing, № 1.4581 / UNS-J92900 / similar AISI 316Nb (...-VA/...-OVA)              |                                     |                                     |
| Dimensions (L x W x H)               | Aluminium housing ~ 180 x 107 x 66 mm, stainless steel housing ~ 195 x 127 x 70 mm (each without connectors)   |                                     |                                     |
| Weight                               | ~ 950 g aluminium housing, stainless steel version ~ 2,5 kg  |                                     |                                     |
| Ambient temperature                  | -20...+50 °C, storage temperature -35...+70 °C   |                                     |                                     |
| Ambient humidity                     | 0...95 % rH, non condensing  |                                     |                                     |
| Sensor circuit                       | Internal circuit   |                                     |                                     |
| Sensor                               | Piezo pressure transmitter   |                                     |                                     |
| Pressure connection                  | P+ / P- sleeves $\varnothing$ 4...6 mm. OCT versions have 2 stainless steel (316L) tube connections for clamp ring fittings $\varnothing$ 6 mm   |                                     |                                     |
| Measuring range                      | 0...100 Pa   | 0...500 Pa                          | 0...5000 Pa                         |
|                                      | Minimum measuring range is 5 % of full range (e.g. 25 Pa at ...500 Pa switch)  |                                     |                                     |
| Response time of sensor              | T90 / 5 s  |                                     |                                     |
| Accuracy of pressure                 | < $\pm$ 1 % typically, max. $\pm$ 5 % of end value $\pm$ 1 Pa  |                                     |                                     |
| Setting range hysteresis             | 0,1...10 Pa (factory setting 2 Pa)   | 0,5...50 Pa (factory setting 10 Pa) | 5...500 Pa (factory setting 100 Pa) |
| Start delay                          | 5 s  |                                     |                                     |
| Start-up bypass time (AUB)           | 3...240 s (factory setting 120 s)  |                                     |                                     |
| Switch activation delay              | 0...240 s (factory setting 0 s / Off)  | -                                   | -                                   |
| Setting zero point                   | Via menu. Short-circuit mechanically both tube connectors P+ / P- for the moment of zero point setting   |                                     |                                     |
| Output                               | Potential free switching contact – breaking/making contact, adjustable per menu<br>max. rating load: 0,5 A (30 VAC/DC) – 0,1 A (250 VAC) – 0,1 A (220 VDC); min. rating load: 10 mW / 0,1 V / 1 mA |                                     |                                     |
| Additional relay output (type ...-2) | -  | as above                            | as above                            |
| Duration of life Mechanical          | 10 x 10 <sup>6</sup>   |                                     |                                     |
| Electrical (rated load)              | 100 x 10 <sup>3</sup>  |                                     |                                     |
| Wiring diagram                       | SB 1.0   |                                     |                                     |
| Scope of delivery                    | Pressure switch, 3 self-tapping screws 4,2 x 13 mm resp. in stainless steel (with ...CT and ...VA versions), short circuit tube  |                                     |                                     |

### Approbations

|                      |                            |
|----------------------|----------------------------|
| CE identification    | CE                         |
| EMC directive        | 2014/30/EU                 |
| Enclosure protection | IP66 in acc. with EN 60529 |
| EAC                  | TC N RU Д-DE.AB45.B.58607  |

### Special solutions and accessories

|                 |  |
|-----------------|--|
| ...-CT          | Types in aluminium housing with seawater resistant coating, parts nickel-plated            |
| ...-OCT         | Offshore version in aluminium housing with seawater resistant coating, parts nickel-plated |
| ...-VA          | Types in stainless steel housing, parts nickel-plated                                      |
| ...-OVA         | Offshore version in stainless steel housing, parts nickel-plated                           |
| MKR             | Mounting bracket for round ducts up to $\varnothing$ 600 mm                                |
| Kit 2           | Flexible pressure tube, 2 m, inner $\varnothing$ 6 mm, 2 connection nipples                |
| Kit-S8-CBR      | 2 cable glands M16 x 1,5 mm, Ex-e, brass nickel-plated, for cable $\varnothing$ 5...10 mm  |
| Kit-Offs-GL-CBR | 2 cable glands M20 x 1,5 mm, Ex-d, Ms-Ni, for armoured cables                              |
| Kit-PTC-CBR     | 2 connecting tubes for tube fittings $\varnothing$ 6 mm, stainless steel 316 L             |

### Electrical connection

All pressure switches require a 24 VAC/DC power supply. The electrical wiring must be realized via the integrated terminal box.

**Attention:** Before opening the terminal box cover, the supply voltage must be shut off!

The supply has to be connected at terminals 1 (-/-) and 2 (+/+).

The start-up bypass delay (AUB) can be activated by bridging terminals 2–3. Activation is indicated by a flashing green LED.



At different relay and supply voltages (24 VAC/DC) the cable installation must be considered (see "Information for Installation")!



InBin-P...

SB 1.0

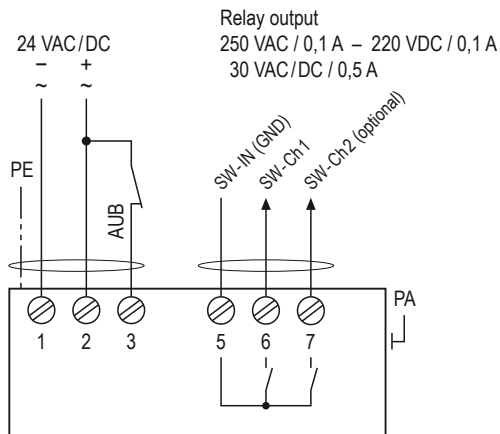

Switching function normally open or closed can be selected via menu only.

### Zero point compensation

...Bin-P-... pressure switches are equipped with a zero point compensation to adjust the module to the installation position. The pressure nipples P+ / P- must be connected with a short circuit tube and the zero point compensation performed by following the menu for parametrisation (menu 14).

Before starting the zero point compensation, the device should be connected to power supply for a minimum of 15 minutes to reach the uniform working temperature!

### Display, buttons and parameters

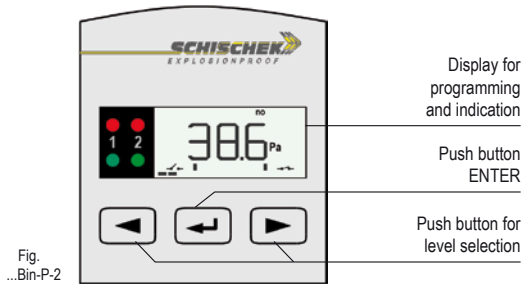



Fig. ...Bin-P-2

#### Change operation – parametrisation mode

To change from operation to parametrisation mode and vice versa, push  ENTER button for minimum of 3 seconds. Back to operation mode with menu "save".

#### Indication of data logging

A flashing unit symbol (star) in the display shows that data is received and the device is working.

#### Password input

The default/delivery setup is 0000. In this configuration the password input is not activated. To activate the password protection (menu 15) change the 4 digits into your chosen numbers (e.g. 1234) and press ENTER.

Please keep your password in mind for next parameter change! Due to a new parameter setup the password is requested.

### Important information for installation and operation

#### A. Installation, commissioning, maintenance

All national and international standards, rules and regulations must be complied with. Apparatus must be installed in accordance with manufacturer instructions.

If the equipment is used in a manner not specified by the manufacturer, the safety protection provided by the equipment may be impaired.



**Attention:** Apply all rules and regulation before opening the internal terminal box. Do not open cover when circuits are live!

Draw the wiring cables through the cable glands. For connection use the internal terminal box and connect equipotential bonding.

After connection install the cables in a fixed position and protect them against mechanical and thermal damage. Close all openings and ensure IP protection (min. IP66).

Avoid temperature transfer and ensure not to exceed max. ambient temperature! For outdoor installation a protective shield against sun, rain and snow should be applied.

After mounting and installation a zero point compensation must be done to ensure correct measurement results (see description).

Sensors are maintenance free. An annual inspection is recommended. Clean with damp cloth only.

Sensors must not be opened and repaired by the end user.

#### B. Long cabling

We recommend using shielded signal wires and to connect one end of the shield to the ...Bin-... terminal box.

#### C. Separate ground wires

For supply and signal wires use separate grounds.

#### D. Relay output

Wires for safety extra-low voltage must be installed separately from other circuits. At 24 VAC/DC only supply and signal wires are permitted in one cable, in all other cases use separate or double isolated cables. An over-current protection fuse < 10 A has to be provided by the installer.



**Dimensions [mm]**

**Aluminium housing**

...Bin-P...-OCT

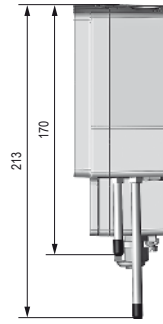
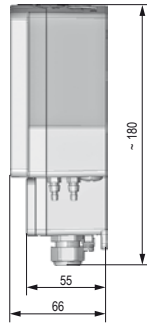
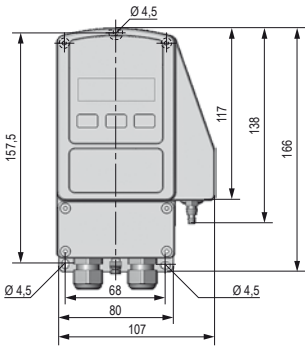

**Stainless steel housing**

...Bin-P...-OVA

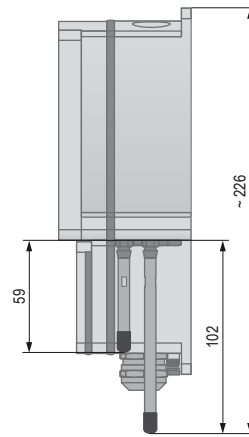
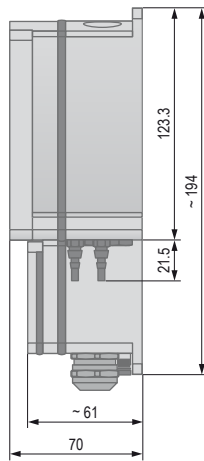
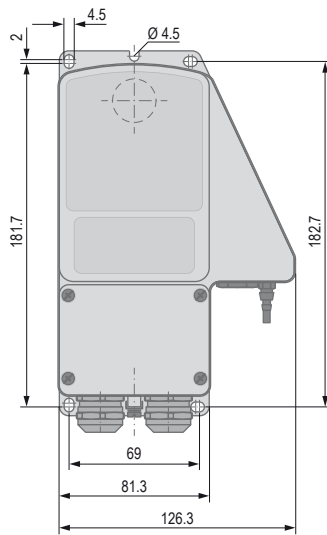

**Parametrisation and commissioning**

To change from operation to parametrisation mode push the "ENTER" button for minimum 3 seconds.  
If password protected: type password and push .  
Skip menu with , back to operation mode with menu "save".

Operation → Parametrisation  
push for min. 3 s



| Menu   | Function  | ENTER | Indication        | Select | ENTER | Next indication | Select                       | ENTER | Next menu |
|--------|---|-------|-------------------|--------|-------|-----------------|------------------------------|-------|-----------|
| Menu 1 | <b>Preset</b><br>Select application   |       | Menu 1<br>PRO     |        |       |                 |                              |       |           |
| Menu 2 | <b>Unit sensor</b><br>Select physical unit                                    |       | Menu 2<br>Pa      |        |       |                 | Pa, mbar, inH <sub>2</sub> O |       |           |
| Menu 3 | <b>set 1</b><br>Select switching point 1                                      |       | Menu 3<br>1000 Pa |        |       |                 | enter setpoint               |       |           |
| Menu 4 | <b>set 2 (optional)*</b><br>Select switching point 2                          |       | Menu 4<br>4000 Pa |        |       |                 | enter setpoint               |       |           |
| Menu 5 | <b>hysteresis**</b><br>Select hysteresis                                      |       | Menu 5<br>100 Pa  |        |       |                 | enter hysteresis             |       |           |
| Menu 6 | <b>mode**</b><br>Select switching properties<br>(break contact, make contact) |       | Menu 6<br>UP      |        |       | Menu 6<br>nc    |                              |       |           |
| Menu 7 | no function – menu skip   |       |                   |        |       |                 |                              |       |           |

Continue next page

InBin-P\_en  
V02 – 18-Oct-2016

Special options

...-CT

...-OCT

...-VA

...-OVA

Continue Parametrisation

| Menu    | Function   | ENTER              | Indication     | Select | ENTER | Next indication                       | Select | ENTER | Next menu                     |
|---------|--|--------------------|----------------|--------|-------|---------------------------------------|--------|-------|-------------------------------|
| Menu 8  | no function – menu skip  |                    |                |        |       |                                       |        |       |                               |
| Menu 9  | no function – menu skip  |                    |                |        |       |                                       |        |       |                               |
| Menu 10 | no function – menu skip  |                    |                |        |       |                                       |        |       |                               |
| Menu 11 | no function – menu skip  |                    |                |        |       |                                       |        |       |                               |
| Menu 12 | <b>time</b><br>Select bypass (AUB) time  | *Menu12+<br>E TIME | Menu12<br>100  | ←      | →     | enter seconds for AUB                 | ←      | →     | ▶                             |
| Menu 13 | <b>display setting</b><br>Select display   | *Menu13+<br>LAMP   | Menu13<br>ON   | ←      | →     | on, off                               | ←      | →     | ▶                             |
| Menu 14 | <b>Zero point compensation</b><br>Sensor's calibration for its installation position | *Menu14+<br>0-Pt   | Menu14<br>FUN  | ←      |       |                                       |        |       |                               |
| Menu 15 | <b>security</b><br>Select password protection  | *Menu15+<br>SECU   | Menu15<br>0000 | ←      | →     | enter password                        | ←      | →     | ▶                             |
| Menu 16 | <b>save</b><br>Select: save data, discard, back to menu, factory setting             | *Menu16+<br>SAVE   | Menu16<br>YES  | ←      | →     | Yes, no, menu, dset (default setting) | ←      | →     | (operation mode after "save") |

\* for ...Bin-P...-2 only (2-stage)

\*\* adjustable in professional mode only (menu 1)

Menu 1 "pset" – Preset

For some applications you can select presetting to ease parametrisation. Besides fan belt („FAN") and filter monitoring („FILT") the professional mode („PRO") is available for further applications.

Professional mode

Menu 1  
**PRO**

When this mode is selected the switching properties can be set at will per menu 5 ("hysteresis") and 6 ("mode") acc. to requirements.

Fan speed monitoring

Menu 1  
**FAN**

The preset "FAN" hides menu 5 ("hysteresis") and 6 ("mode") during parametrisation. The corresponding values are set automatically.

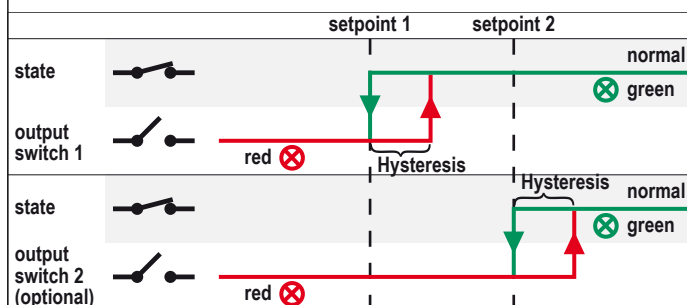
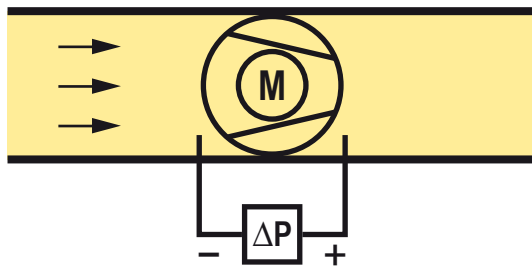

Filter monitoring

Menu 1  
**FILT**

The preset "FILT" hides menu 5 ("hysteresis") and 6 ("mode") during parametrisation. The corresponding values are set automatically.

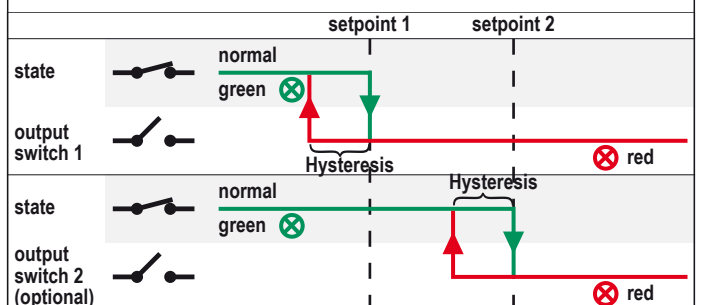
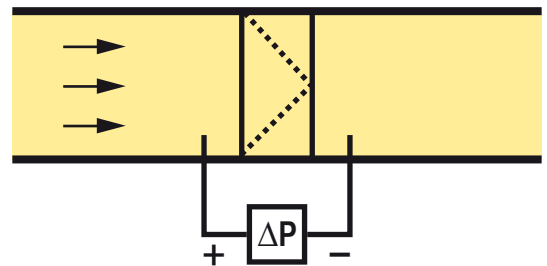

Menu 6 "mode" – Switching properties

1. Define the device's normal range first:

- The device should indicate (green LED) when the temperature/humidity is
  - above the setpoints – mode „up-range“ has to be selected.
  - under the setpoints – mode „down-range“ has to be selected.
  - between the setpoints – mode „mid-range“ has to be selected.
- This mode is available for 2-stage devices only (...Bin-P...-2).

2. Select the switching characteristic of the output relay:

- When the measured value is in normal range, the corresponding relays shall
  - close – select "normally closed" (nc)
  - open – select "normally open" (no)

