

Data Sheet

B METERS WDE-K50

Woltmann Type Water Meters



Supplied by

247able.com

Call us on +44 (0)118 916 9420 | Email info@247able.com



WDE-K50

Woltmann type pre-equipped
for inductive modules

The WDE-K50 is a horizontal Woltmann with a removable insert and sealed counter mechanism with a magnetic transmission.

Inductive pre-equipment for the installation of data communication modules M-BUS wired and wireless M-BUS, non-magnetic pulse output and LoRa.



TECHNICAL FEATURES

Size	DN	mm (in)	50 (2")	65 (2 1/2")	80 (3")	100 (4")	125 (5")	150 (6")	200 (8")
Overload flow rate	Q ₄	m ³ /h	50	78.75	125	200	200	312.5	500
Permanent flow rate	Q ₃	m ³ /h	40	63	100	160	160	250	400
Transitional flow rate	Q ₂	m ³ /h	0.64	1.008	1.60	2.56	2.56	4.00	6.40
Minimum flow rate	Q ₁	m ³ /h	0.40	0.63	1.00	1.60	1.60	2.5	4.0
Transitional flow rate	Q ₂	m ³ /h	0.40	0.63	1.00	1.60	1.60	2.50	4.00
Minimum flow rate	Q ₁	m ³ /h	0.25	0.394	0.625	1.00	1.00	1.563	2.50
Minimum reading		l	0.5	0.5	0.5	0.5	0.5	5	5
Maximum reading		m ³			9,999,999			9,999,999	
Maximum pressure loss at Q ₃		bar	0.25	0.40	0.25	0.40	0.40	0.16	0.40
Maximum admissible pressure MAP		bar	16	16	16	16	16	16	16

R=100H ↑

R=160H ↑

DIMENSIONS & WEIGHTS

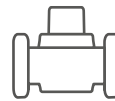
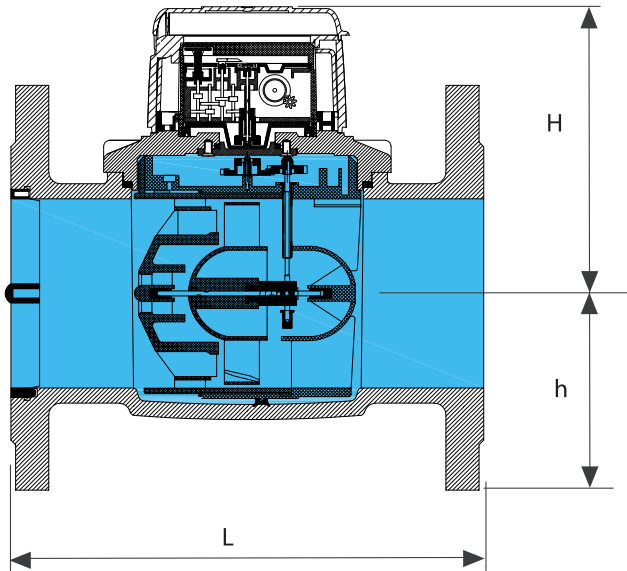

R 100H
R 160H
R 250H



R 100H
R 160H

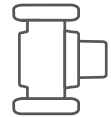

R 100V
R 160V

Size	mm (in)	50 (2")	65 (2" 1/2)	80 (3")	100 (4")	125 (5")	150 (6")	200 (8")
L	mm	200	200	225	250	250	300	350
H	mm	130	130	152	152	152	181	181
h	mm	78	86	95	104	117	133	162
Weight	Kg	8.5	9.5	13.5	15	18	30.5	43



DESIGNING, PRODUCING AND DISTRIBUTING SOLUTIONS FOR OVER 25 YEARS

B METERS is an Italian company that has been designing, producing and distributing instruments and solutions for measuring the consumption of water and thermal energy used for heating and cooling, for over 25 years.

The yearly production currently exceeds 2M units, putting B METERS in a leading position both at national and European level.

The product range includes turbine (velocity) type single and multi-jet water meters with mechanical or magnetic transmission, Woltmann meters, irrigation meters, flow meters, thermal energy meters and heat cost allocators with direct reading, or complete with integrated modules for the remote transmission of the consumption data.



EN 1434

EN 834

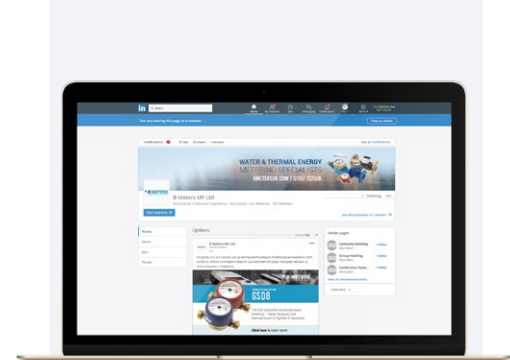

**FOLLOW BMETERS ON LINKEDIN,
KEEP UP-TO-DATE WITH ALL
LATEST NEWS AND PRODUCT
INFORMATION**

THE BMETERS RANGE



WATER METERS



THERMAL ENERGY METERS



READING SYSTEMS



M-BUS SOLUTIONS