

Installation & Maintenance Instructions

# UE ONE SERIES

Electronic Pressure, Differential Pressure  
and Temperature Switches



Supplied by

**247cable.com**

Call us on +44 (0)118 916 9420 | Email [info@247able.com](mailto:info@247able.com)



# One Series Electronic Pressure, Differential Pressure and Temperature Switches



UNITED ELECTRIC  
CONTROLS

**Discrete Input, Intrinsically Safe,  
Flameproof and Non-Incendive  
Models: 1XSWLL, 1XSWHL, and 1XSWHH**

## Installation and Maintenance Instructions

Please read all instructional literature carefully and thoroughly before starting. Refer to the final page for the listing of Recommended Practices, Liabilities and Warranties. All Warnings are translated to French and can be found on pages 21 and 22.

### GENERAL

 MISUSE OF THIS PRODUCT MAY CAUSE EXPLOSION AND PERSONAL INJURY. THESE INSTRUCTIONS MUST BE THOROUGHLY READ AND UNDERSTOOD BEFORE UNIT IS INSTALLED. SEE THE PRODUCT NAMEPLATE INFORMATION FOR SPECIFIC AGENCY CERTIFICATIONS APPLICABLE TO YOUR PRODUCT.

 SUBSTITUTION OF COMPONENTS MAY IMPAIR SUITABILITY FOR USE IN HAZARDOUS LOCATIONS. CABLE GLANDS USED MUST BE RATED FOR A MINIMUM OF IP66 IN ORDER TO MAINTAIN THE SAME IP RATING.

 FOR ZONE HAZARDOUS LOCATIONS, ALL CABLE ENTRY DEVICES SHALL BE CERTIFIED IN TYPE OF EXPLOSION PROTECTION FLAMEPROOF ENCLOSURE "d" WITH AN IP66 RATING, SUITABLE FOR THE CONDITIONS OF USE AND CORRECTLY INSTALLED. IF CABLES AND CABLE GLANDS ARE NOT USED, A STOPPING BOX SHALL BE PROVIDED WITHIN 2" OF THE ENCLOSURE. FLAMEPROOF JOINT AND GAP DETAILS ARE PROVIDED ON PAGE 2.

 INSTALL UNITS WHERE SHOCK, VIBRATION AND TEMPERATURE FLUCTUATIONS ARE MINIMAL. ORIENT UNIT TO PREVENT MOISTURE FROM ENTERING ENCLOSURE. USE PROPERLY RATED SEALING FITTINGS FOR ELECTRICAL WIRE ENTRY. DO NOT MOUNT UNIT IN AMBIENT TEMPERATURES EXCEEDING PUBLISHED LIMITS. THIS IS ESPECIALLY CRITICAL FOR LOCAL MOUNT TEMPERATURE UNITS. USE OF A SHROUD IS RECOMMENDED WHERE DIRECT SUNLIGHT AND RAIN MAY COME IN CONTACT WITH THE ENCLOSURE.

**DURING INSTALLATION, MARK THE BOX NEXT TO EACH PROTECTION METHOD ON THE NAMEPLATE THAT APPLIES TO YOUR APPLICATION.**

**THIS EQUIPMENT IS CERTIFIED IN ACCORDANCE WITH THE REQUIREMENTS OF THE FOLLOWING APPLICABLE STANDARDS (SEE TABLE 1) AND IS SUITABLE FOR USE IN NON-HAZARDOUS AND THE FOLLOWING HAZARDOUS LOCATIONS, AND IS ATEX AND IECX CERTIFIED SUITABLE FOR APPROPRIATE USE IN GAS AND DUST ZONE 1 APPLICATIONS.**

	N. America	Europe	International
Intrinsic Safety - Model 1XSWLL Only			
Cert number:	Report Reference: E226592-20150623	DEMKO 09 ATEX 0813748X	IECEx UL 08.0017X
Applicable Standards	UL 913, UL-60079-0, UL 60079-11, CSA C22.2 No. 157, CSA C22.2 No. 60079-0, CSA C22.2 No. 60079-11	EN 60079-0 EN 60079-11	IEC 60079-0 IEC 60069-11
Suitable for appropriate use in: EXIA Intrinsically Safe - Sécurité Intrinsèque	Class I, Div. 1, Groups A, B, C & D Class II, Div. 1 Groups E, F & G Class III Class I, Zone 0 AEx ia IIC T4 Ex ia IIC T4	II 1 G Ex ia IIC T4 Ga II 1 D Ex ia IIIC T135°C Da -40°C ≤ TAMB ≤ +85°C	Ex ia IIC T4 Ga Ex ia IIIC T135°C Da -40°C ≤ TAMB ≤ +85°C
Flameproof - Models 1XSWLL, 1XSWHL and 1XSWHH			
Cert Number:	UL File E226592	DEMKO 09 ATEX 0813748X	IECEx UL 08.0017X
Applicable Standards	UL 1203, UL 60079-0, UL 60079-1, UL 61010-1, UL 50, UL 50E, CSA C22.2 No. 25, CSA C22.2 No. 30, CSA C22.2 No. 60079-0, CSA C22.2 No. 60079-1, CSA C22.2 No. 61010-1, CSA C22.2 No. 94.01, CSA C22.2 No. 94.2	EN 60079-0 EN 60079-1 EN 60079-31	IEC 60079-0 IEC 60079-1 IEC 60079-31
Suitable for appropriate use in:	Class I, Div. 1, Groups A, B, C & D Class II, Div. 1 Groups E, F & G Class III Class I, Zone 1 AEx db IIC T5 (1XSWLL) Class I, Zone 1 Ex db IIC T5 Class I, Zone 1 AEx db IIC T3/T5 (1XSWHL & 1XSWHH)	II 2 G Ex db IIC T3/T5 Gb II 2 D Ex tb IIIC T90°C Db IP66 -40°C ≤ TAMB ≤ +85°C (1XSWLL) -40°C ≤ TAMB ≤ +80°C (1XSWHL & 1XSWHH)	Ex db IIC T3/T5 Gb Ex tb IIIC T90°C Db IP66 -40°C ≤ TAMB ≤ +85°C (1XSWLL) -40°C ≤ TAMB ≤ +80°C (1XSWHL & 1XSWHH)

To see standard revision/edition number, refer to actual certificate (e.g. DEMKO 09 ATEX 0813748X) on UE website: <https://www.ueonline.com/support/certifications/?product=one-series&region=International>

Non-Incendive - Model 1XSWLL, 1XSWHL and 1XSWHH			
	N. America	Europe	International
Cert number:	Report Reference: E226592-20150623	DEMKO 15 ATEX 1483	IECEX UL 08.0017X
Applicable Standards	UL-60079-0, UL 60079-15, ISA 12.12.01, CSA C22.2 No. 157, CSA C22.2 No. 213, CSA C22.2 No. 60079-0, CSA C22.2 No. 60079-15	EN 60079-0 EN 60079-15	IEC 60079-0 IEC 60079-15
Suitable for appropriate use in:	Class I, Div. 2, Groups A, B, C & D Class II, Div. 2 Groups F & G Class III Class I, Zone 2 AEx nA IIC T5 Ex nA IIC T5	II 3 G Ex nA IIC T4 Gc	Ex nA IIC T4 Gc

Table 1

For standard revision/edition number, refer to actual certificate (e.g. DEMKO 09 ATEX 0813748X) on UE website: <https://www.ueonline.com/support/certifications/?product=one-series&region=International>

## FLAMEPROOF - SPECIAL CONDITIONS FOR SAFE USE

- Field wiring must be rated 105°C minimum. For ambient temperatures below -10°C, use suitable field wiring.
- Blanking elements from factory have been tested for flameproof "d" and dust "tb" with the enclosure as an assembly and carry no markings.
- A suitable thermowell made from corrosion-resistant material and engaging 5 threads minimum (with thread sealant) is required for the local spring loaded temperature sensor to maintain IP66

### Flameproof joint and gap details

- Enclosure to cover threaded joint: 4" - 16 UN-2, 7 threads engaged minimum
- Glass to cover cemented joint: 0.753" (19.1 mm) rabbet/spigot minimum length
- Breather element threaded joint: M8-1.25 (6g/6H medium fit class), 11 threads engaged minimum
- Electrical conduit threaded joint: 3/4"-14 NPT, 5 threads engaged minimum
- Enclosure to sensor threaded joint:
  - Pressure models: 1"-20 UNEF-2, 10 threads engaged minimum
  - Temperature models: 1/2"-14 NPT, 5 threads engaged minimum
  - Remote and local spring loaded temperature sensor gap joints: 0.0045" (0.114 mm) maximum annular gap by 1.25" (31.8 mm) minimum length
- The Unit must be cleaned with a damp cloth to avoid static discharge.

### Dual Seal Adaptor (Option M041)

- Threaded Dual Seal Adaptor Option Enclosure to One Series Enclosure : 1"-20 UNEF-2, 10 threads engaged minimum
- Breather element threaded joint: 1/4"-20 UNC-2, 10 threads engaged minimum
- Secondary Seal Housing to union housing joint: 0.580" (14.73 mm) rabbet/spigot minimum length, maximum annular gap 0.003 in. (0.08 mm)
- Sensor to union housing joint: 0.580" (14.73 mm) rabbet/spigot minimum length, maximum gap 0.003 in. (0.08 mm)
- Threaded Dual Seal Adaptor option to Sensor 1"-20 UNEF-2, 10 threads engaged minimum or 1/2"-14 NPT 5 threads engaged minimum.

## INTRINSIC SAFETY - SPECIAL CONDITIONS FOR SAFE USE

- Enclosure and cover are made from Aluminum Alloy, do not strike with heavy object.
- Separation distances were assessed to Annex F.
- Device must be powered by a galvanically isolated intrinsic safety barrier.



CONTINUOUS OPERATION SHOULD NOT EXCEED THE DESIGNATED OVER RANGE PRESSURE OR WORKING PRESSURE RANGE STATED WITHIN THE LITERATURE AND ON DEVICE NAMEPLATE.

**Over Range Pressure:** The maximum pressure to which a pressure sensor may be continuously subjected without cause damage and maintaining set point repeatability.

**Max Working Pressure:** The maximum that can be applied to both process ports simultaneously without affecting sensor performance.

The One Series electronic switch product line is based on an all-solid-state electronic module that incorporates a microprocessor. The combination of features like no moving parts and IAW™ self-diagnostics provide a highly reliable, accurate and repeatable monitor for detecting pressure and temperature thresholds which once reached, can make intelligent switch decisions based upon retained settings and current conditions. The One Series monitors its own health and reports the status locally through the IAW™ (I Am Working) feature that provides a solution to the “blind device” issue common with mechanical switches. You will always know the health status of the One Series.

The One Series is also very rugged, featuring a Type 4X, weather-tight enclosure suitable for harsh environments and hazardous (Class I, Division 1) locations. The 0.5% accuracy rating is maintained over a very wide -40°C to +70°C operating range using active temperature compensation. Repeatability is 0.1% of full range while the switch set point and deadband (hysteresis) is fully programmable over the entire range of the sensor. Reaction time for the One Series to a process change is typically 100 mS or less.

## 2-WIRE SIMPLICITY (MODEL 1XSWLL AND 1XSWHL)

The One Series 2-Wire electronic switch is designed to operate on discrete input leakage current. The microprocessor-based One Series is the only switch to operate and switch over a single pair of wires, similar to a traditional mechanical switch. It combines the simplicity and low cost features of a switch and the reliability features found in a transmitter and without the need to provide additional wiring.

- Models 1XSWLL and 1XSWHL are designed to work with most Programmable Logic Controller (PLC) or Distributed Control System (DCS) discrete inputs and some interposing relays. When open, the switch draws 750 µA (max); when closed, the switch sinks or sources 0.1 A maximum.

## I Am Working (IAW™)

The One Series also contains UE’s patented IAW™ self-diagnostic software. On a continuous basis, the IAW™ algorithm checks for proper operation, and locally reports the status using messages or revolving arrows on the display. For remote reporting, a discrete IAW™ Output signal can be monitored by the control system and used to detect normal, tripped, and fault conditions. IAW™ self-monitors, searching for possible faults, both within the instrument and in the overall system (see Fault Codes, table 4, page 16). In the event of a detected fault, the One Series will attempt to display the fault details and provide remote electrical indication by opening (turning off) the IAW™ Output. In the case of certain micro-controller faults, the revolving arrow may freeze or go out; indicating locally that a failure exists.

## DISPLAY FEATURES AND DIAGNOSTICS

The One Series features a large, easy to read LCD display (see Figure 1). It is used for three main purposes: process indication, programming of key features and switch status/troubleshooting.

In the Process Display mode, the display may be indicating the following:

- Current process value and units of measure: A value will be displayed as long as the reading is within 110% of the full scale range noted on the nameplate.
- I Am Working (IAW™) status: When the unit is working properly, a circular 4-segment arrow will be revolving around the letters “IAW” in the top center of the display.
- Offset/Span Adjustment: The word “offset” will appear above the process value, indicating that the factory offset and/or span calibration has been modified by the user.

In addition, the user can easily access information such as the set point, deadband and minimum/maximum process readings:

By pushing the right → button once, the display will scroll as follows:

SP1 XX.XX DB1 XX.XX

By pushing the left ↓ button once, the display will scroll the min/max process values recorded in memory:

MAX XX.XX MIN XX.XX

The display will automatically revert back to the Process Display mode after scrolling.

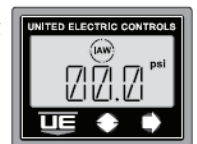

Figure 1

## ALARM CONDITION

When the process goes beyond the set point, the display will begin to flash, alternating between the process value and “SW1”. The display



will continue to flash until the process has returned to a value beyond the deadband, at which point the display will revert to normal operation and process value display. If the unit was programmed to have a latching output, a small "Latch" icon will light in the display when the set point is reached, indicating that the output is latched and needs to be manually reset.

## FAULT CONDITIONS

In the case of a fault condition, the display may indicate the following:

If the IAW™ software detects a fault outside of the micro-controller, and can still operate, it will display an error message.

If the fault is one which affects the micro-controller or the display, the revolving arrow around "IAW" will either freeze or go out.

If it is a failure of the power supply or the wiring, the display will go blank.

(See Fault Codes, page 16 for a complete description of fault diagnostics.)

Please refer to the product technical brochure for product specifications. Product technical brochure may be found at [www.ueonline.com](http://www.ueonline.com).

UE declarations and third party issued certifications are available for download at [www.ueonline.com/support/certifications/](http://www.ueonline.com/support/certifications/).

Date code format on nameplate is "YYWW" for year and week (see Figure 13, Page 17)

## PART I - MOUNTING

### FLAMEPROOF, NON-INCENDIVE, INTRINSIC SAFETY - MOUNTING

**Tools Required:** Screwdriver for mounting bolts; 4 mounting bolts (1/4" Max.)

**NOTE:** For optional surface and pipe mounting kit, order part no. 6361-704. See page 19.



BEFORE INSTALLING, CHECK THE SENSOR MODEL SELECTED FOR COMPATIBILITY TO THE PROCESS MEDIA IN CONTACT WITH THE SENSOR AND WETTED PARTS.



IN ALL APPLICATIONS, SECURE THE ENCLOSURE AS DETAILED BELOW. DO NOT MOUNT VIA THE PROCESS CONNECTION ONLY.

Mount the device using the four (4) 1/4" clearance holes in the enclosure base. Plumb sensor to the process port. See page 19 for dimensions.

The device may be mounted in any position except with the sensor connection facing up. Ensure the process connection is sealed to the process port to prevent leakage. Care should be taken to minimize effects of shock and vibration. The One Series should be protected from direct sunlight and rain in outdoor installations using a shroud (user supplied). **NOTE:** the optimal display viewing position is 6:00.



FOR PRESSURE AND LOCAL TEMPERATURE MODELS ALWAYS HOLD A WRENCH ON THE SENSOR HEX WHEN MOUNTING THE DEVICE. DO NOT TIGHTEN BY TURNING ENCLOSURE, THIS WILL DAMAGE THE CONNECTION BETWEEN THE SENSOR AND HOUSING.



FOR DIFFERENTIAL PRESSURE MODELS (ESPECIALLY LOW RANGE MODELS), MOUNT THE SENSOR LEVEL TO MINIMIZE ANY PRESSURE READING OFFSETS. THE OFFSET COMMAND MAY BE USED TO ZERO THE DISPLAY (SEE PAGE 12 FOR ADDITIONAL INFORMATION).

## PROCESS CONNECTIONS AND SENSOR FOR FLAMEPROOF, NON-INCENDIVE AND INTRINSIC SAFETY INSTALLATIONS



NEVER INSERT ANY OBJECT INTO THE PRESSURE SENSOR OPENING. DAMAGE TO THE SENSOR WILL RESULT, AFFECTING ACCURACY.

### Pressure and Differential Pressure Models

To pipe mount: Thread the pressure connection onto the pressure port, with thread sealant, making sure that the mating threads are clean and free of debris. Use a wrench on the pressure connection hex to tighten. Test for leaks. On Differential Pressure models, the Low (L) side pressure must NOT exceed the high (H) side pressure. Damage to the sensor may result.

## Local and Remote Temperature Models

For Local Ambient Sensing (model L): Mount using the mounting holes on the electronics housing. Mount the device to ensure

that the sensor housing will not be damaged and where the measured temperature is representative of the surrounding environment.

For Local Spring-Loaded (model T): A suitable thermowell, made from corrosion-resistant material, 5 threads engaged minimum, with thread sealant, is required to maintain enclosure type 4X/IP66.

For Remote Sensing: Route the extension wire to avoid contact with live components or close proximity to electrical noise sources. Avoid kinks, or excessive flexing. Tighten the ferrule fitting, if applicable.

For Surface Sensing: Secure the sensor housing to the pipe or vessel using an adhesive or strapping method suitable for the application.

For Immersion Sensing (models C, H, R & L): Use of a thermowell is highly recommended to aid in maintenance, testing and preservation of the system integrity. Insert the sensor housing (0.25" diameter) into the well ensuring that the sensor's sheath bottoms out and the well is completely immersed in the media (2.5" min.) Screw the sensor's nipple into the thermowell, with thread sealant, by placing a wrench on the union nut. Tighten the union connector.

For best temperature measurements, the sensor housing must be in full contact with the surface or media being measured. Heat transfer compound may be used to aid in fully transferring the media temperature to the sensor housing. Locate where the temperature is most representative of the system. Minimum insertion depth is 2-1/2". Sensor dimensional drawings are shown on page 20.

## PART II - WIRING

### Removing the One Series Enclosure Cover and Display Module



TO PREVENT ELECTROSTATIC DISCHARGE WIPE DOWN COVER AND ENCLOSURE OF ANY DUST BUILD-UP BEFORE REMOVING COVER.



DISCONNECT ALL SUPPLY CIRCUITS BEFORE WIRING DEVICE. WIRE DEVICE IN ACCORDANCE WITH LOCAL AND NATIONAL ELECTRICAL CODES. MAXIMUM RECOMMENDED WIRE SIZE AND TIGHTENING TORQUE FOR FIELD WIRING TERMINAL BLOCKS ARE SHOWN WITHIN TABLE 3(PAGE 8).



TO PREVENT SEIZURE OF ENCLOSURE COVER, DO NOT REMOVE LUBRICANT. THREADS SHOULD ALSO BE FREE OF DIRT AND OTHER CONTAMINANTS.

Remove the enclosure cover by turning it counter-clockwise for 7 revolutions (Figure 2). Carefully remove the display module by grasping the outer edge and pulling it away from the base enclosure (Figure 3), being careful not to strain any of the wired connections. Allow the display module to hang from the wired connections to access the base enclosure and terminal blocks for wiring. Do not remove the display module wire assemblies. Insert the field wiring through the conduit opening(s) of the base enclosure. Make the connections as shown within the wiring diagrams beginning (Figures 4-8, page 6-7). The primary chassis and equipment grounding terminal is provided inside the base enclosure.

Cleaning the display and keypad surface should be performed with a damp cloth only. Do not attempt to wash down the One Series with the cover removed.

### WIRING FOR FLAMEPROOF & NON-INCENDIVE INSTALLATIONS

**Tools Required:** Small flat-head screwdriver; wire strippers



TO PREVENT IGNITION, DISCONNECT POWER BEFORE REMOVING ENCLOSURE COVER. KEEP COVER TIGHT WHILE IN OPERATION. DO NOT DISCONNECT EQUIPMENT UNLESS POWER HAS BEEN SWITCHED OFF OR THE AREA IS KNOWN TO BE NON-HAZARDOUS.



DO NOT REPLACE COMPONENTS UNLESS POWER HAS BEEN SWITCHED OFF OR THE AREA IS KNOWN TO BE NON-HAZARDOUS.



THE DEVICES SHALL BE PROPERLY GROUNDED IN THE END USE APPLICATION USING THE GROUND SCREWS PROVIDED WITH THE ENCLOSURE.



FIELD WIRING MUST BE RATED 105°C MINIMUM. FOR AMBIENT TEMPERATURES BELOW -10°C, USE SUITABLE FIELD WIRING. USE COPPER WIRES ONLY - ALUMINUM WIRE NOT ALLOWED! INSTALL ALL CLASS 2 WIRING WITHIN FLEXIBLE TUBING TO MAINTAIN SEGREGATION BETWEEN CIRCUITS.



MODELS 1XSWLL AND 1XSWHL DERIVE THEIR POWER DIRECTLY FROM A PLC/DCS DISCRETE INPUT OR OTHER LOW-CURRENT DC LOADS (Figures 4-5, page 6). THE SWITCHED OUTPUT MAXIMUM LOAD RATING IS 0.1A. **THE DEVICE MUST NOT BE CONNECTED DIRECTLY TO A POWER SUPPLY WITHOUT AN APPROPRIATE CURRENT LIMITING LOAD SUCH AS THAT PROVIDED BY A PLC/DCS DISCRETE INPUT. OVERLOADING THE SWITCH MAY CAUSE FAILURE (SEE TABLE 2).**

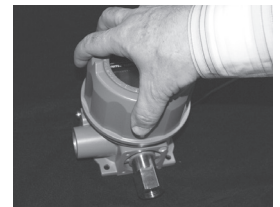

Figure 2



Figure 3

Maximum Switch Ratings – Flameproof and Non-Incendive			
Model	Signal Name	Voltage Rating	Current Rating
1XSWLL	SW	7.8 – 50.0 VDC	0.1 amperes <sup>1</sup>
	IAW	7.8 – 50.0 VDC	0.1 amperes <sup>1</sup>
1XSWHL	SW	70 – 240 VAC/VDC	0.1 amperes <sup>1</sup>
	IAW	7.8 – 50.0 VDC	0.1 amperes <sup>1</sup>
1XSWHH	SW	70 – 240 VAC	0.150 – 10 amperes <sup>2</sup>
	IAW	7.8 – 50.0 VDC	0.1 amperes <sup>1</sup>

<sup>1</sup>Derate at 0.001 amperes per °C above 25°C  
<sup>2</sup>Derate at 1 ampere per 5.5°C above 38°C ambient

Table 2

### WIRING DIAGRAMS - Models 1XSWLL and 1XSWHL

SW and IAW  
PLC Inputs Circuit

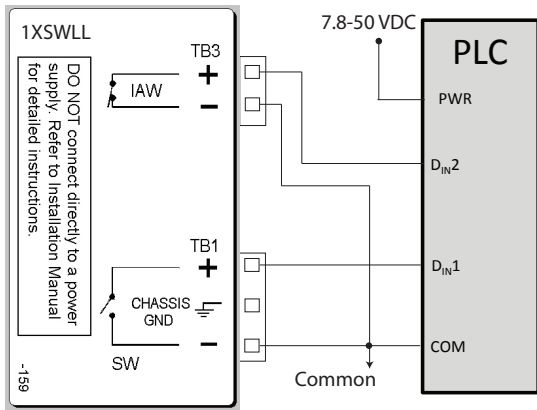

Figure 4

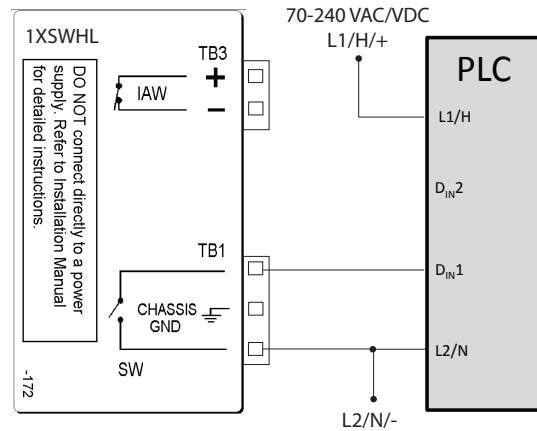

Figure 5

Interposing  
Relay with  
IAW Circuit

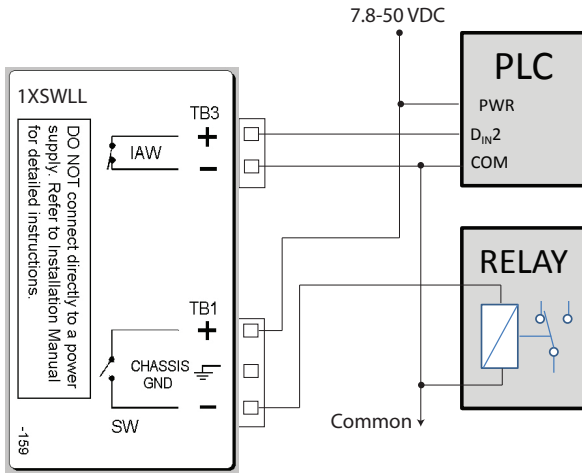

Figure 6

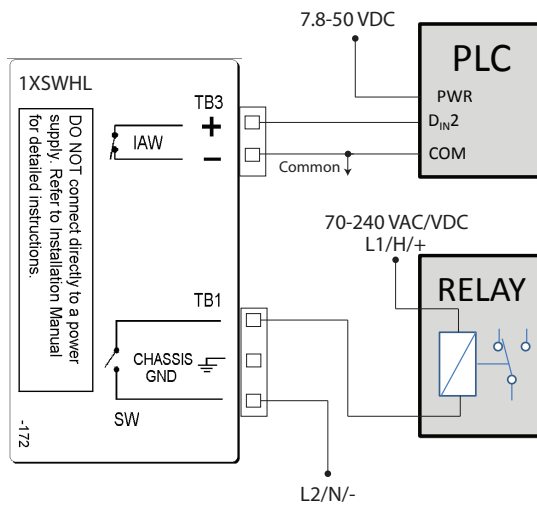

Figure 7

Models 1XSWLL and 1XSWHL can also be wired in series with the coil of certain interposing relays, as shown in figures 6-7. The relay coil specifications must not exceed the maximum switch ratings. (See Table 2, page 6).

**NOTE:** For bench testing model 1XSWLL, a circuit is required as shown in figure 8. These components are not included and must be provided by the user. **Do not connect model 1XSWLL directly to a power supply without a suitable load in series with the switch.** Do not exceed the maximum switch ratings or permanent damage may result (See table 2 on page 6).

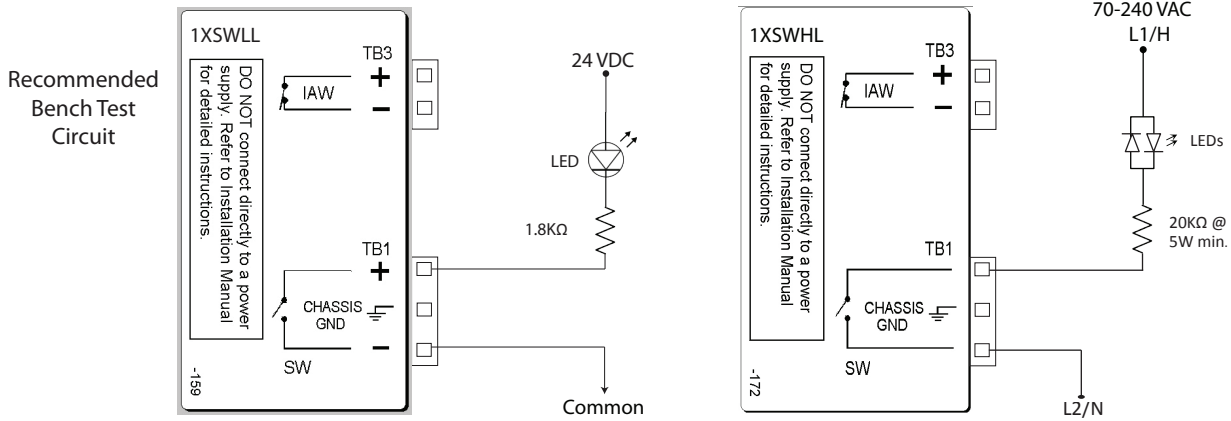

Figure 8

## WIRING DIAGRAMS - Model 1XSWHH

Model 1XSWHH requires 70 – 240 VAC @ 0.015 A external power supply for each device. Power for all One Series functions are provided by this power supply connection at TB2, terminals C (L1/H) and D (L2/N). Connections for the programmable solid state relay switch are made at TB2 terminals A and B. (refer to table 2, page 6 and table 3, page 8).

The wiring diagram below (Figure 9) provides a view inside the One Series base enclosure with the display module removed. TB2 is located there. All models include a separate IAW™ switched output located at TB3 on the back of the display module. This signal provides the health status of the One Series and is normally closed. When open, this signal provides an indication that IAW™ has detected a fault condition. Monitor this signal by connecting it to the discrete input of a PLC or DCS. The IAW™ wiring connection is not required if remote health status of the One Series is not used.

**NOTE:** The solid state relay switch in model 1XSWHH has a minimum load requirement of 0.150 A making it incompatible with control system inputs. Do not exceed the maximum switch ratings (see table 2, page 6) or permanent damage to the One Series may result.

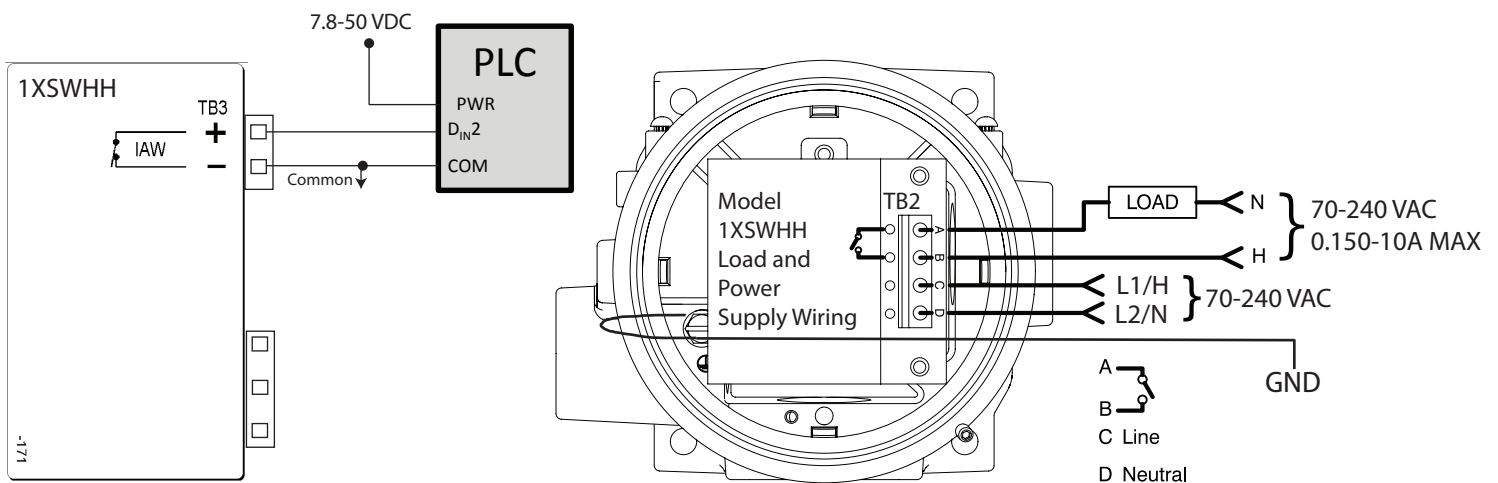

Base Enclosure

Figure 9



## Terminal Block and Torque Details for Flameproof, Non-Incendive and Intrinsic Safety Installations

Terminal	Description	Max. Wire Gauge	Min. Wire Gauge	Recommended Tightening Torque
TB1	3-Position	14 AWG	22 AWG	7 in-lbs.
TB2	4-Position	10 AWG	20 AWG	4.4 in-lbs.
TB3	2-Position	14 AWG	22 AWG	7 in-lbs.

Table 3

### INTRINSIC SAFETY WIRING DIAGRAMS - MODEL 1XSWLL (Use Class 2 or SELV Power Supply Only)

**Model 1XSWLL** is intended for direct connection to a PLC or DCS discrete input, or other suitable load (see graph 1, page 15). Power is obtained and the discrete switch signal is provided by the same two-wire connection. Polarity must be observed. (refer to Table 2, page 6) for switch ratings.



**DO NOT CONNECT MODEL 1XSWLL DIRECTLY TO A POWER SUPPLY WITHOUT A SUITABLE LOAD IN SERIES WITH THE SWITCH.**

For 1XSWLL models, only one conduit opening is required. The unused conduit opening must include an explosion-proof/flameproof plug, made from a corrosion-resistant material, suitable for all gas and dust groups as listed on the nameplate. Blanking elements from factory have been tested with the enclosure as an assembly and carry no markings.

#### SELECTING AN INTRINSIC SAFETY BARRIER (Model 1XSWLL)

For Intrinsically-Safe (I.S.) installations, please reference the Control Drawing UE 62174–64 for Intrinsic Safety entity parameters and wiring information (<https://www.ueonline.com/support/product-drawings/>). Model 1XSWLL must be wired to an approved I.S. galvanically isolated barrier for Zone 0 EPL Ga and Class I, Division 1 classifications. The information provided is for reference only and is intended to act as a guide in the selection of a suitable I.S. Barrier.



**SUBSTITUTION OF COMPONENTS MAY IMPAIR INTRINSIC SAFETY.**

Installation of Intrinsically-Safe circuits must be performed in accordance with the requirements of the government and/or other local authority having jurisdiction. System components and installation methods must be approved by the appropriate recognized approval authority.

There are two general types of I.S. Barriers, shunt diode (passive) safety barriers and transformer isolated barriers. Shunt diode safety barriers are not recommended for use with model 1XSWLL.

#### Transformer Isolated Barriers:

Due to the unique method by which the model 1XSWLL operates, a specifically designed isolated barrier must be used. Any safety barrier that adheres to NAMUR standard EN 60947-5-6 for proximity and dry contact switches may be used to achieve intrinsic safety with the One Series model 1XSWLL.

#### Recommended NAMUR standard transformer isolated intrinsic safety barriers:

Pepperl+Fuchs models KCD2-SR-Ex1.LB and KFD2-SR2-Ex1.W.LB

Figure 4 (page 6) shows a typical wiring scheme depicting model 1XSWLL connected to a programmable logic controller (PLC), distributed control system (DCS) or other logic solver discrete input.

## Part III - PROGRAMMING

**Tools Required:** Programming Flowchart, page 18

Programming of the One Series is accomplished using the two buttons on the faceplate (labeled ↓ and → - See Figure 10). Stepping down through the main menu using the left ↓ button, you can access the various commands of the One Series software menu. The right button is then used to move into the command submenu for setting up or modifying the parameters.

**NOTE:** The flowchart on page 18 shows the entire programming commands menu structure. Before removing the enclosure cover, please read the instructions on page 5. The One Series programming menu is a single direction loop, with submenus embedded within, so there is no way to back up in the program. If you need to make a correction to a prior Main Menu step, you will need to continue forward, exit and then re-enter the program and step through to the appropriate feature. If you are in a Submenu, you will need to continue to the beginning of the menu item and re-enter the Submenu to make the correction.

### Entering the Programming Mode

**NOTE:** While in the Programming Mode, the One Series will remove itself from service (go offline). All outputs are set to the fail safe state and the One Series ignores process variable input from the process sensor. The IAW™ Output signal will open. The switch output failsafe state will be based on the programmed operating mode of the switch. For example, the failsafe state for “Open on” modes is open. The control system will interpret these signals as a detected fault and a process upset (set point reached) simultaneously.

**It is essential to alert the control system operators before entering the Programming Mode.**

Use the Flowchart on page 18 as a guide through the various commands in the Programming Mode.

- Press and release both buttons ↓→ simultaneously and then press the right button → to enter the password.
- Enter the 4-digit password. The factory default password is “0000”.
  - The left ↓ button increments the blinking digit.
  - The right → button sets the digit and moves to the next.
  - Once a valid password is entered, “OK” will appear on the display.
- Press and release the right → button.
  - CLR MAX/MIN (or MAN RSET if Latch is set) will appear on the display.

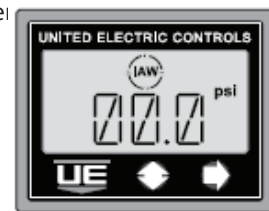

Figure 10

This is the first command prompt in the Programming Mode.

**NOTE:** The One Series will automatically exit the Programming Mode and resume monitoring the process (go back online) if two minutes elapse without a button being pressed. The One Series recalls all previously saved parameters from memory and any program changes that were made will be discarded. This two-minute timeout feature prevents the One Series from being left offline accidentally.

### Exiting the Programming Mode

When any of the program commands are displayed, it is possible to escape and exit the Programming Mode by pressing the left ↓ and right → button simultaneously. Doing this redirects the programmer to the Save Changes menu location, which is only possible at menu actions indicated by an asterisk (\*) on the Programming Flowchart, found on page 18.

**NOTE:** It is also possible to exit the Programming Mode by repeatedly pressing the left ↓ button from any program command until the Save Changes menu location is reached.

### Saving Programming Changes

When changes have been made to the program settings, a choice is provided to Save or Discard the changes. At any prompt:

- Press both left ↓ and right → buttons to display SAVE CHNG menu.

To Save changes, press the right → button. NO (the default) will be displayed.

- Press the left ↓ button to toggle and display YES.
- Then press both left ↓ and right → buttons to confirm, save the changes and return to the Process Display mode.

The One Series will resume process monitoring (go back online) using the new program parameters.

To Discard changes, press the right → button. NO will be displayed.

- Press both left ↓ and right → buttons to confirm, discard changes and return to the Process Display mode.

The One Series will resume monitoring the process (go back online) recalling all previously saved parameters from memory.

## BASIC FEATURES

### Setting the Units of Measure

The One Series allows the units of measure to be set in the field. The default units are pounds per square inch (PSI) for pressure models and degrees Fahrenheit (°F) for temperature models.

- To change the units of measure, enter the programming mode. Press the left ↓ button. The display will scroll SET UNITS.
- Press the right → button and the display will read the default units psi or °F.
- Repeatedly press and release the left ↓ button to select from the available choices. Stop at the desired choice.
- Press the right → button to make the selection. The display will return to “Set Units.”
- Press the left ↓ button to continue on in the menu or press both left ↓ and right → buttons to exit the Programming Mode and save changes.

**NOTE:** MAX/MIN memory is reset (changed to zero) whenever the units of measure have been changed. Set Point, Deadband, Offset, Span and Plug Port values are recalculated for the newly selected units of measure.

### Setting the Switch Mode, Set Point and Deadband

Please refer to the Programming Flowchart, page 18.

- Enter the programming mode (see page 9).
- Press and release the left ↓ button until SW1 appears on the display.
- Press the right → button. The previously selected mode will appear. OPEN RISE is the factory default.

The One Series has six available modes of operation

OPEN RISE - Switch opens on rising process values that exceed the set point.

OPEN FALL - Switch opens on falling process values that drop below the set point

OPEN WINDOW - Switch opens when process values go outside programmed limits specified by set point high and set point low.

CLOSE RISE - Switch closes on rising process values that exceed the set point.

CLOSE FALL - Switch closes on falling process values that drop below the set point.

CLOSE WINDOW - Switch closes when process values go outside programmed limits specified by set point high and set point low.

**Note:** “OPEN” Modes are recommended in safety applications where a DTT (De-energize to Trip) output is required. This ensures that the switch output will go to the fail safe state in the event of a power loss or line break. The IAW™ output always operates in DTT mode.

Please use the Switch Decision Logic (Figure 11, page 11) for help with setting the appropriate switch mode.

- Press and release the left ↓ button until the desired mode appears.
- Press the right → button to select the mode and move on to the set point. SP will appear.

**NOTE:** The set point is the process value at which the One Series opens or closes the switch. The Set Point is fully programmable throughout the operating range of the sensor as noted on the device nameplate.

- Press the right → button to select a positive or negative set point. POS is the default. Use the left ↓ button to change to NEG.
- Press the right → button to view and change the set point. Press the left ↓ button to increment the blinking digit. Press the right → button to enter and move to the next digit.
- Press the right → button to enter a new Deadband. DB will show on the display.

**NOTE:** The Deadband is the amount above or below the set point at which the One Series resets the switch, returning it to the normally closed or open state. Deadband is represented as a value which is added or subtracted from set point, depending on the control mode.

- Example 1: If the Control Mode is OPEN RISE and the set point is 100 and the deadband is 10, the Switch will open as pressure rises to 100 and close (reset) as the pressure falls to 90.
- Example 2: If the Control Mode is CLOSE RISE and the set point is 100 and the deadband is 10, the Switch will close as pressure rises to 100 and open (reset) as the pressure falls to 90.
- Example 3: If the Control Mode is OPEN FALL and the set point is 100 psi and the deadband is 10, the Switch will open as pressure falls to 100 psi and close (reset) as pressure rises to 110 psi.
- Example 4: If the Control Mode is CLOSE FALL and the set point is 100 psi and the deadband is 10, the Switch will close as pressure falls to 100 psi and open (reset) as pressure rises to 110 psi.

**NOTE:** Deadband should be set wide enough so that frequent or rapid switch cycling (chatter) does not occur but narrow enough to satisfy the process conditions. A Deadband value of zero is undefined and, therefore, not permitted.

- Press the right → button to view and change deadband. Press the left ↓ button to increment the blinking digit. Press the right → button to enter and move to the next digit.
- Press the right → button to enter a new Deadband. SW1 will show on the display.

### Switch Decision Logic

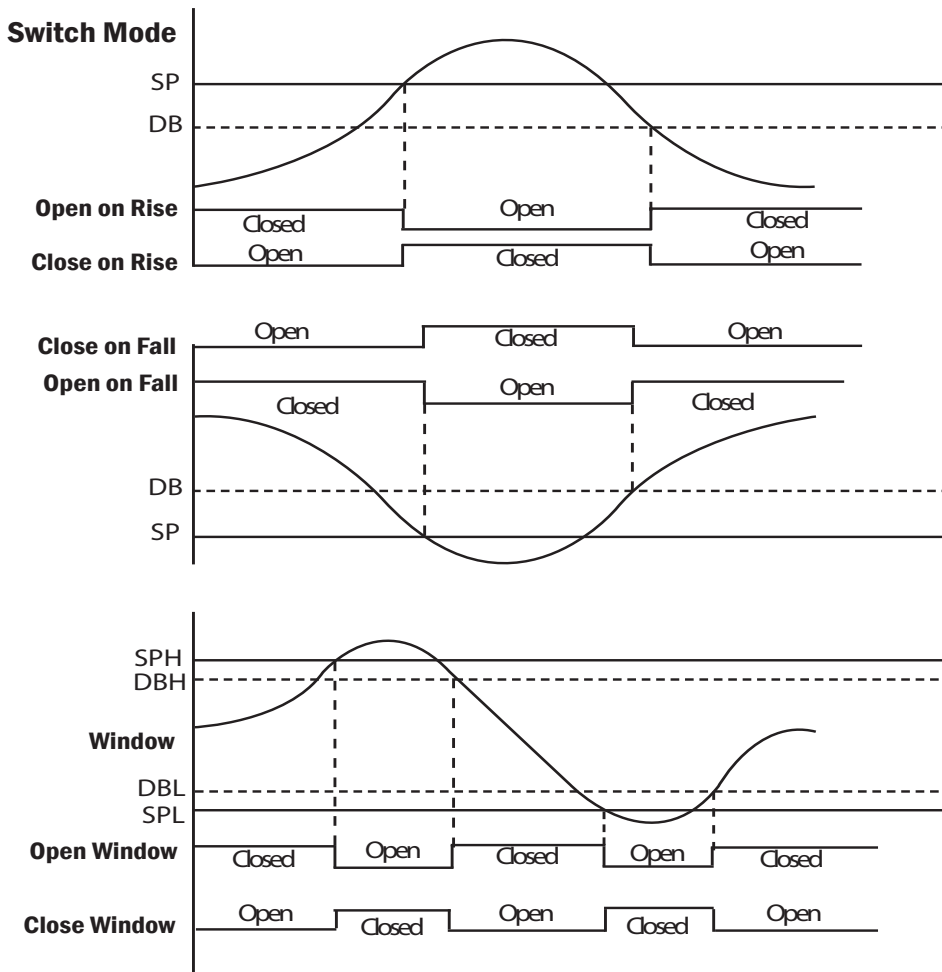

Figure 11

**NOTE:** The Set Point and Deadband settings are subject to the accuracy of the instrument. Actual switch points may vary up to  $\pm 0.5\%$  of the sensor's maximum range at room temperature. Example: The P15 sensor has a range of 0 to 300 psi. When setting a Set Point of 150, the actual switch point may occur between 148.5 and 151.5 due to the accuracy error of  $\pm 1.5$  ( $300 \times 0.5\%$ ).

### Resetting the Maximum & Minimum Values

The One Series continuously captures the readings from the sensor and stores one minimum and maximum value since the last time they were reset. The values can be viewed at any time by removing the enclosure cover and pushing the left ↓ button. The display will scroll the values and then return to the Process Display mode.

To reset the values, enter the Programming Mode (see page 9). Repeatedly press the left ↓ button to get to the CLR MAX/MIN command and then press the right → button two times. After exiting the Programming Mode and saving the changes (see page 9), the values will be reset to the current reading and begin recording again.

## ADVANCED FEATURES

**NOTE:** No initial programming of these features is required. The default for these advanced commands is zero or off.

### Adjusting Display Offset

The One Series is factory calibrated to 0.25% of the sensor's maximum range at room temperature. In some installations, it may be necessary to adjust the display's offset due to the range and position of the sensor. Chemical seals with long capillaries combined with low maximum range sensors are a common cause of offset error. The OFFSET command allows the user to enter a positive ("POS") or negative ("NEG") offset to the display readings. An offset adjustment of up to  $\pm 10\%$  of the sensor's maximum range is allowed.

**Example:** When the sensor has a zero pressure applied, but the display reads a value other than zero, entering the additive inverse (reversing the sign) of the displayed value for OFFSET will force the display to read zero.

**NOTE:** Any numerical value entered other than 0.00 will cause the display to indicate "Offset" just above the process reading in the process display.



USE OF THIS OPTION MAY CREATE A CONDITION WHERE THE DISPLAY MAY INDICATE "0.00" WHEN SIGNIFICANT PRESSURE OR TEMPERATURE (UP TO 10% OF MAXIMUM RANGE) EXISTS IN THE SYSTEM. INDEPENDENT VERIFICATION OF THE PROCESS VARIABLE SHOULD BE DONE PRIOR TO MAINTENANCE ON THE SYSTEM WHEN "OFFSET" APPEARS ON THE DISPLAY.

Refer to the Programming Flowchart on page 18.

- Enter the Programming Mode and use the left ↓ button to move to the OFST command.
- Press the right → button to select a positive or negative offset. POS is default. Use the left ↓ button to change to NEG.
- Press the right → button to view and change the offset. Zero is the factory setting. Press the left ↓ button to increment the blinking digit. Press the right → button to enter and move to the next digit. Press the right → button to enter the new offset and return to the main menu.

### Adjusting Span

SPAN provides an adjustment to shift the slope of the sensor's response curve to accommodate an offset value other than zero. To adjust SPAN, calculate and enter a new SPAN value.

To calculate the SPAN value, apply a reference source below maximum scale to the sensor. Record the value that shows on the One Series display and the reference source value. Divide the reference source value by the display value and then multiply the result by the sensor's upper range.

FORMULA:  $SPAN = \text{reference source} / \text{display value} \times \text{upper range value}$

- Pressure example: For a sensor range of 0 - 100 psi, choose a reference source (90) below the upper range limit (100) to prevent an over range condition. Divide the reference source value from the resulting display value (88). Multiply the result by the upper range limit.  $Span = 90 / 88 \times 100 = 102$  (rounded)
- Temperature example: For a sensor range of -40 to 450°F, choose a reference source (400) below the upper range limit (450) to prevent an over range condition. Divide the reference source value from the resulting display value (404). Multiply the result by the upper range limit.  $Span = 400 / 404 \times 450 = 446$  (rounded)

Refer to the Programming Flowchart on page 18.

- Enter the Programming Mode (see page 9) and use the left ↓ button to move to the SPAN command.
- Press the right → button to select a positive or negative span. POS is the default. Use the left ↓ button to change to NEG.
- Press the right → button to view and change the span. Zero is the factory setting. Press the left ↓ button to increment the blinking digit. Press the right → button to enter and move to the next digit.



- Press the right → button to enter the new span and return to the main menu.

**NOTE:** To return to factory calibration settings, enter all zeros for both SPAN and OFST.

### Setting the Latch Mode (Manual Reset)

The switch can be configured to latch when the set point is reached. Refer to the Programming Flowchart on page 18.

- LCH1: In the Programming Mode, press the right → button.
- If OFF is displayed, press the left ↓ button to set LCH1 to ON.
- Press the right → button to set the latch. When latch mode is on (set), the Switch changes state when the set point is crossed and remains latched until the Switch is manually reset by the user or the One Series is power cycled.

When latched, the display will read MAN RSET.

To Reset the Latch

- Enter the Programming Mode (see page 9). If the Latch is set, the display will read MAN RSET. To return to the Process Display without resetting the latch, press the right → button.
- To continue programming without resetting the latch, press the left ↓ button.
- Press both ↓→ buttons to reset the latch. The display now reads RSET DONE.
- Press the right → button to return to the Process Display.
- Press the left ↓ button to continue programming.

**NOTE:** Interrupting power to the One Series will also reset the latch.

### SETTING THE PLUGGED PORT FEATURE

The One Series IAW™ self-diagnostics have the ability to detect that the process port may be plugged. It does this by monitoring the sensor for changes over time. The amount of change and the time period are programmable. If the process variable does not change by the amount and selected time period, the display will indicate PLUG and the IAW™ Output will open, indicating a fault. Refer to the Programming Flowchart on page 18.

- Enter the Programming Mode and press the left ↓ button until PLUG PORT is scrolling on display. Press the right → button.
- There are four possible selections -
  - OFF - This disables the plugged port function and is the default setting. This should be done where sensor plugging is not a concern or where the system pressures may not change over time (example: a storage tank).
  - 1 minute
  - 1 Hour
  - 24 Hours

} Maximum time with no process variation before fault indication
- Using the left ↓ button, select a time.
- If OFF is selected, press the right → button to return to the PLUG PORT command and leave Plug Port deactivated.
- Press the right → button to enter a process value ≤ 10% of the sensor's maximum range. This number represents the minimum variation expected in the process value over the time period entered above under normal operating conditions. Each time the process value reaches this value, the Plug Port timer is reset.

**NOTE:** This value can be accurately determined by subtracting the minimum from the maximum process value as recorded by the MAX/MIN feature. See RESETTING MAXIMUM AND MINIMUM VALUES on page 11 for additional information.

## Resetting Trip Counter

Trip Count provides information that may be useful for troubleshooting a process. Each time the set point is reached, the trip count is incremented by 1, up to 9999, where it will automatically return to 1. Trip Count is always on and can be manually reset to zero at any time by following these steps.

Refer to the Programming Flowchart on page 18.

- Enter the Programming Mode (see page 9)
- Press and release the left ↓ button until RESET TRIP CNT appears on the display
- Press the right → button. The recorded value of times the set point was reached (the trip count) will appear on the display.
  - Press the right → button to clear (reset) the trip count to zero.
  - Press the left ↓ button to retain the trip count value without resetting.

## Setting the Filter

In some applications, it is desirable to “dampen” the switch response and prevent intermittent false trips due to pressure spikes or other transient/isolated events. The Filter feature provides a software digital filter with a programmable time constant for suppressing certain transient short-duration events.

Refer to the Programming Flowchart on page 18

- Enter the Programming Mode (see page 9) and move through the program until FILTER is scrolling on the display. Press the right → button.
- The available selections are as follows

Pressure Models:	OFF (Default)	Temperature Models:	1/2 second
	1/4 second		1 second
	1/2 second		2 seconds
	1 second		
	2 seconds		

- Using the left ↓ button, select a time constant.
- Press the right → button to enter the time constant and return to main menu.

**NOTE:** The One Series typically responds to a process value change in less than 100 milliseconds when the Filter is set to off. Using this feature can lengthen the overall response time of the One Series for certain types of process value changes (pressure spikes).

- A shorter delay setting provides a faster response but is less stable.
- A longer delay setting provides a slower response and is more stable.

## Setting the Trip Delay

The Trip Delay provides a programmable delay for the switch with a range of 0 – 999.9 seconds. Zero seconds is the factory default. When the set point is reached, the switch trip will be delayed by the number of seconds entered into the Trip Delay command using the following steps.

Refer to the Programming Flowchart on page 18.

- Enter the Programming Mode (see page 9).
- Press and release the left ↓ button until TRIP DELAY scrolls on the display.
- Press the right → button. OFF will appear on the display.
- Press the left ↓ button to select ON. The Trip Delay value in seconds (default = 000.0) will appear on the display with the left digit blinking.
  - Press the left ↓ button to increment the blinking digit.
  - Press the right → button to move to the next digit.
- Press the right → button to enter the new Trip Delay value.

# DISPLAY MODULE CALIBRATION

These serial numbers must match for proper operation.

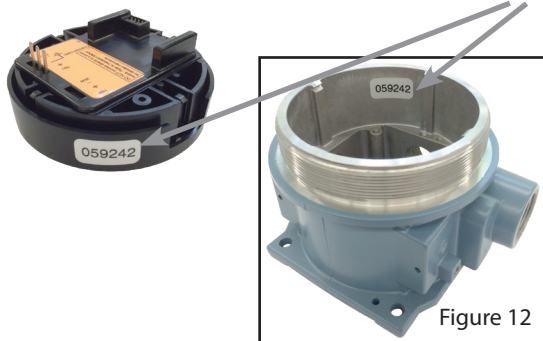

**NOTE:** Do not replace the One Series display module or pressure sensor. Swapping these amongst devices will cause a mis-match between the stored sensor calibration data and the pressure sensor. For proper operation, the display module serial number must always match the serial number inside the enclosure (See Figure 12).

Figure 12

## ACCEPTABLE SUPPLY VOLTAGES AND LOADS FOR 1XSWLL AND 1XSWHL

The graphs below provide a range of acceptable power supply voltages (in Volts) and series loads (in Ohms). This is useful when the One Series is connected to non-standard PLC and DCS inputs or is connected in series with a relay or solenoid coil.

**NOTE:** If you need assistance with determining the compatibility of the One Series with your PLC, DCS, or relay, we can help. Please have the manufacturer's model number ready when you call us. In rare cases, when the series resistor value is too large and falls out of the Acceptable Range, placing another resistor across the input will allow it to work. Please call +1 (617) 923-6977 (Inside Sales) for assistance.

### 1XSWLL Allowable Voltage / Load Characteristics

V <sub>supply</sub>	R <sub>load</sub> (Max)	R <sub>Load</sub> (Min)
8	1111	30
12	2593	70
16	4074	110
20	5556	150
24	7037	190
28	8519	230
32	10000	270
36	11481	310
40	12963	350
44	14444	390
48	15926	430

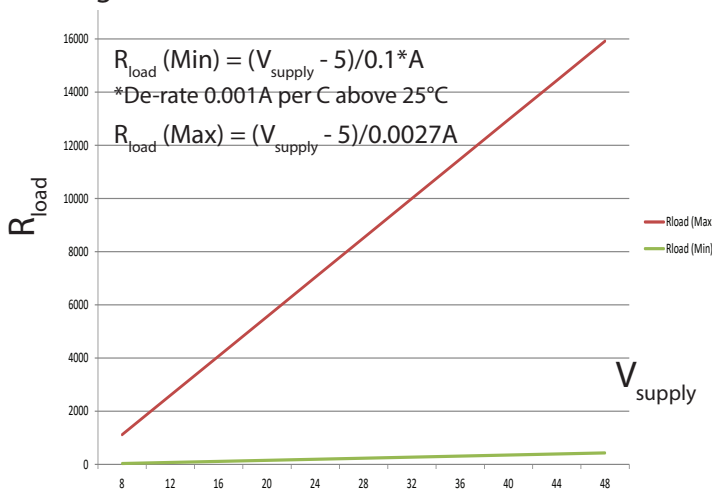

Graph 1

### 1XSWHL Allowable Voltage / Load Characteristics

V <sub>supply</sub>	R <sub>load</sub> (Max)	R <sub>Load</sub> (Min)
70	10000	600
90	13333	800
110	16667	1000
130	20000	1200
150	23333	1400
170	26667	1600
190	30000	1800
210	33333	2000
230	36667	2200
250	40000	2400

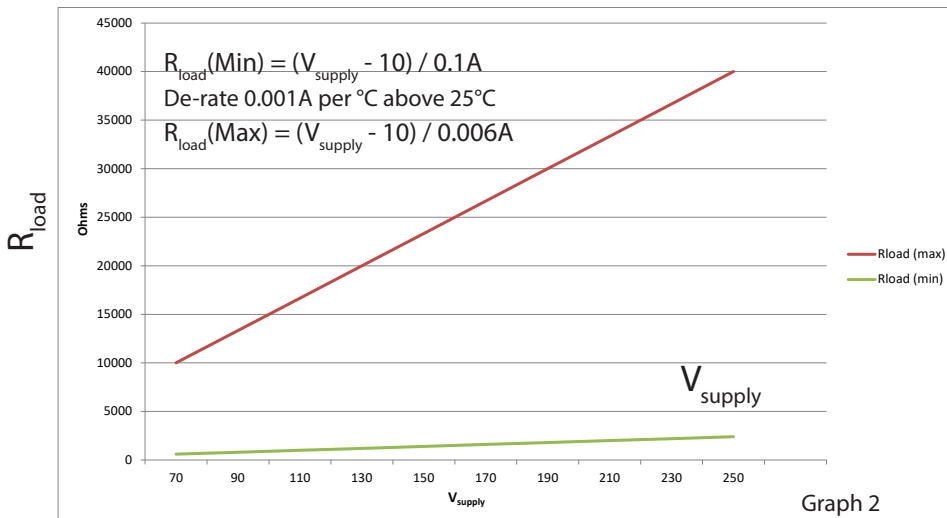

Graph 2

## ONE SERIES FAULT CODES

The One Series IAW™ diagnostics are capable of detecting many possible fault conditions. Some fault conditions will clear automatically when the parameter returns to normal; others require the device to be powered down and restarted; and some may require repair or replacement. A list of fault conditions is shown below:

If a fault message appears on the One Series display, a fault code can be obtained by pressing both keypad buttons ↕→ simultaneously. Please provide this code if calling UE Inside Sales for assistance.

Code		Probable Cause	Reason	Action
E-	04	Loop Current Fault	The current measured in the 4-20mA loop, by the fault monitoring circuitry, is incorrect.	Verify that the power supply voltage and load resistance on the 4-20mA loop are within allowable limits.
E-	15	Diagnostic Fault Sensor OPEN	An open circuit has been detected on the sensor drive pins 2 & 3.	Diagnostic Fault Sensor open, check all sensor connections.
E-	16	Diagnostic Fault Sensor SHORT	A short circuit has been detected on the sensor drive pins 2 & 3.	Diagnostic Fault Sensor Short, check all sensor connections.
E-	18	Diagnostic Fault Relay Monitor	The relay output fault monitor circuit has detected that the output state of the solid state relay is incorrect. This feature must be enabled in the menu.	Check the wiring connections or disable feature if not being used.
E-	65	Error -- switch output	The switch output fault monitor circuit has detected that the switch output state is incorrect.	Internal Hardware Fault, contact factory
E-	88	Error -- Process Variable Extreme Overrange	Extreme overrange, a pressure input has exceeded 150% of the operating range or a temperature input has exceeded 110% of range.	Warning: This fault may indicate damage to the sensor. Check that the process is within the operating limits of the device. Verify all sensor connections.

Table 4

**NOTE:** Power cycling the One Series will reset some faults. If the fault remains after power cycling, please contact UE Inside Sales at [Insidesales@ueonline.com](mailto:Insidesales@ueonline.com) or call +1 (617)-923-6977. Some fault codes not noted above indicate microprocessor faults.

## LOST PASSWORDS

Contact UE Inside Sales at +1-617-923-6977 or go online at [www.UEonline.com/UUC](http://www.UEonline.com/UUC) to obtain a unique unlock code. The Kanban number from the product nameplate is required (see Figure 13).

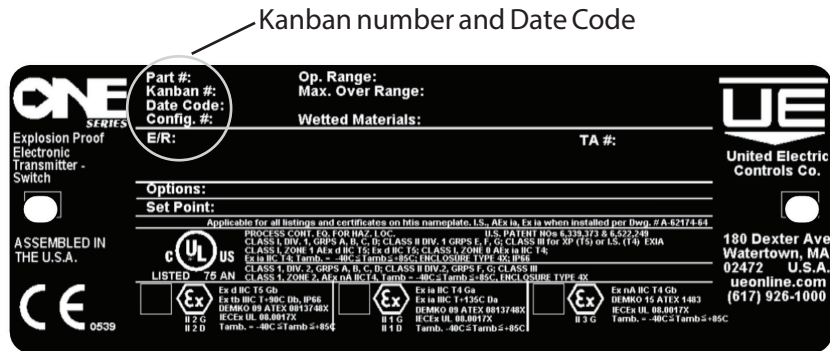

Figure 13

## TROUBLESHOOTING

The switches contained in the One Series are electronic. The on/off switch signal is produced by a transistor or a solid-state relay, depending on the One Series model. Electronic switches cannot be properly tested with an ohmmeter. Instead, measure the voltage drop across the switch connected to the intended load to determine if it is open or closed. A properly functioning One Series electronic switch will exhibit the following voltage levels (see Table 5):

Signal	Location	Voltage Open	Voltage Closed
Serpointswitch 1XSWLL	TB1	Supply voltage (up to 50 VDC)	4.7 VDC (nominal)
Setpointswitch 1XSWHL	TB1	Supply voltage (70-240 VAC, VDC)	13.5 VAC, VDC (nominal)
Setpointswitch 1XSWHH	TB2 A, B	Supply voltage (24-280 VAC, VDC)	0 VAC, VDC (nominal)
I/AWoutputswitch All models	TB3 +, -	Supply voltage (up to 50 VDC)	4.7 VDC (nominal)

Table 5



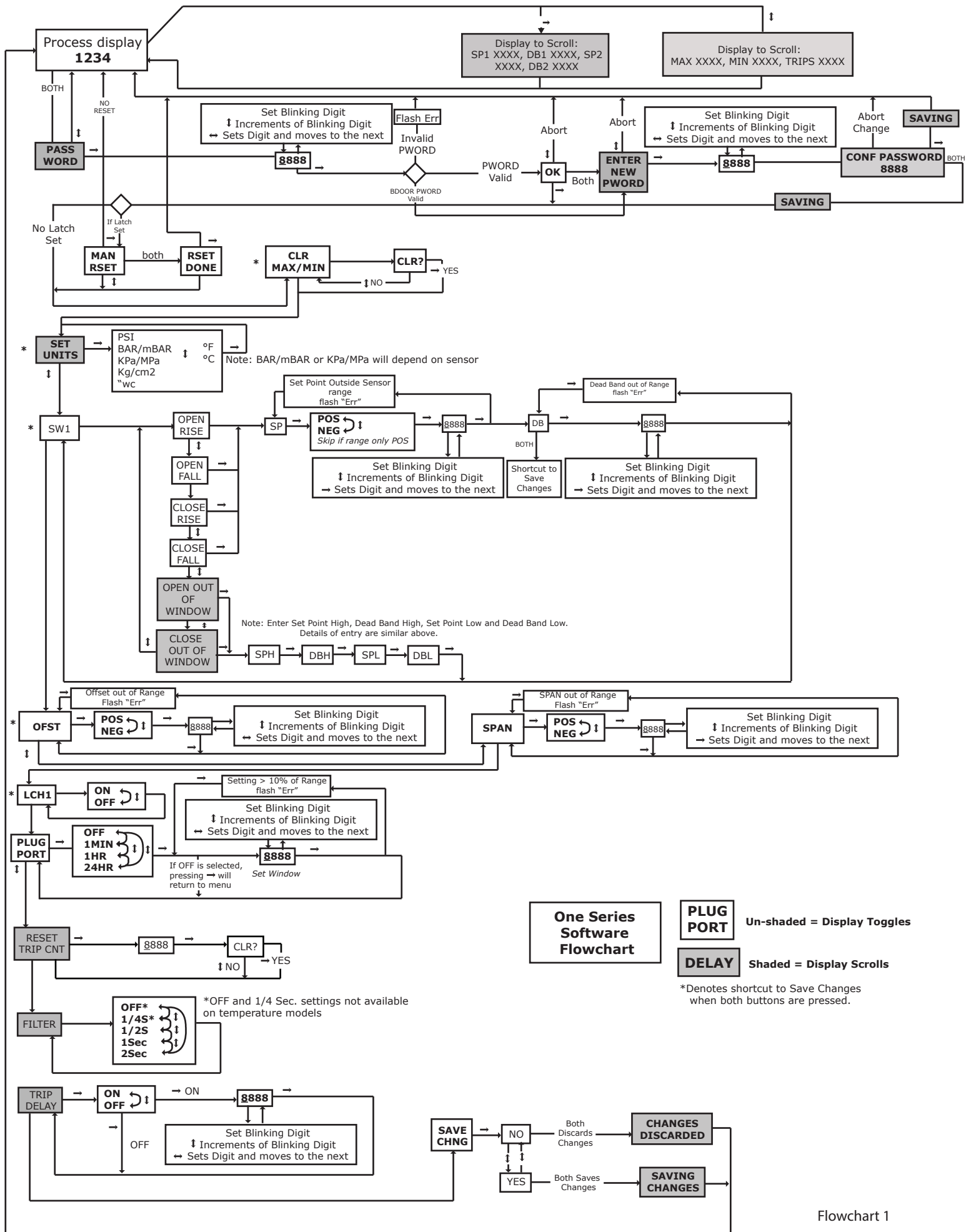

Flowchart 1

# DIMENSIONAL DRAWINGS

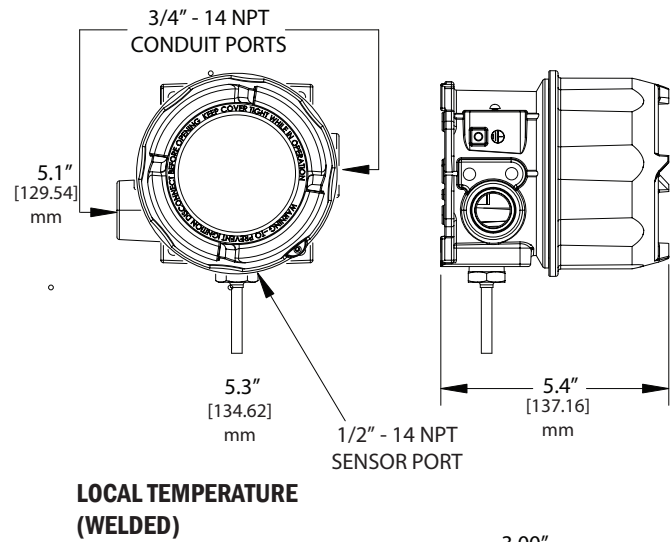
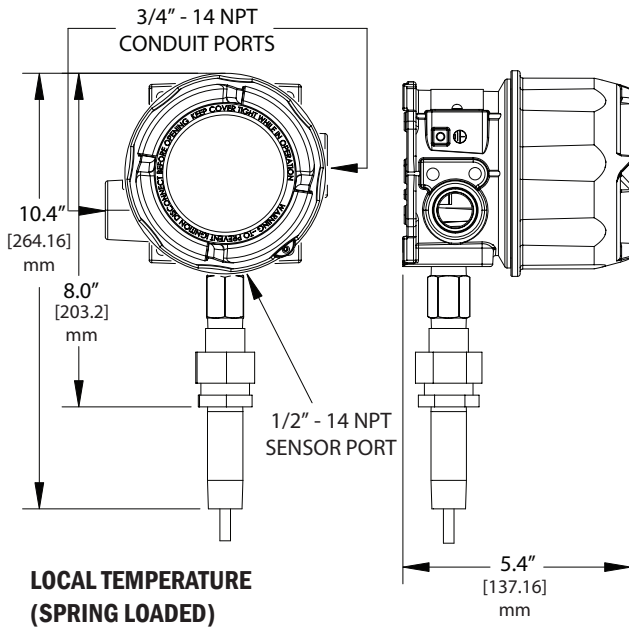
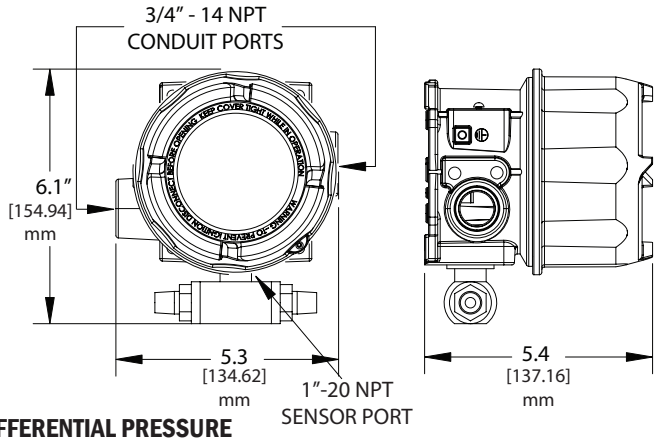
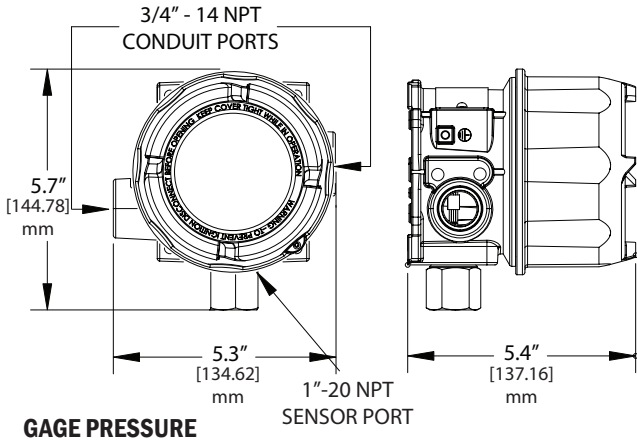

**CLEARANCE HOLE FOR 1/4" BOLT 4 PLCS**

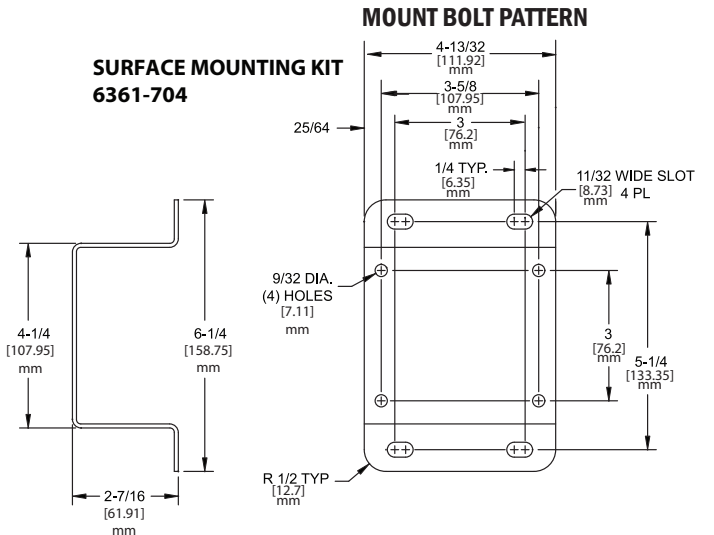
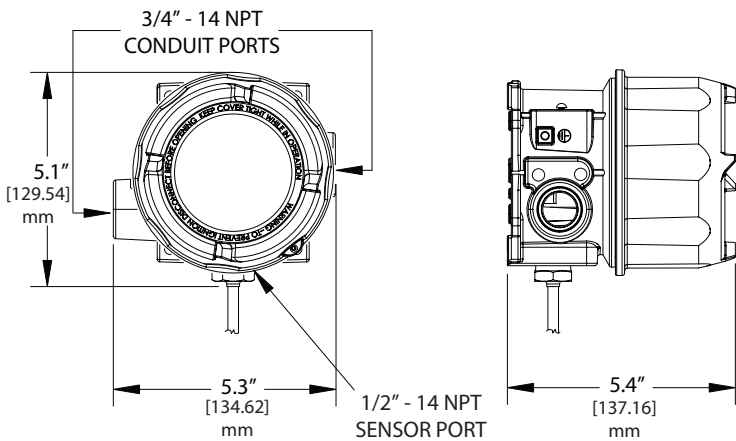
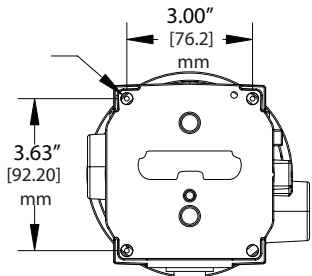

# SENSOR OPTIONS

## Pressure Sensors

### Gauge Pressure

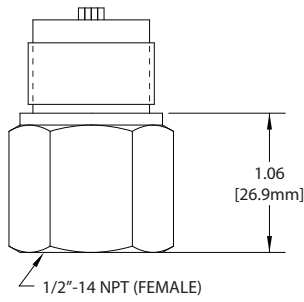

### Differential Pressure

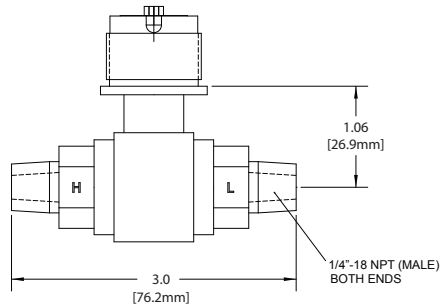

### Dual Seal with Gage Pressure Sensor (Option M041)

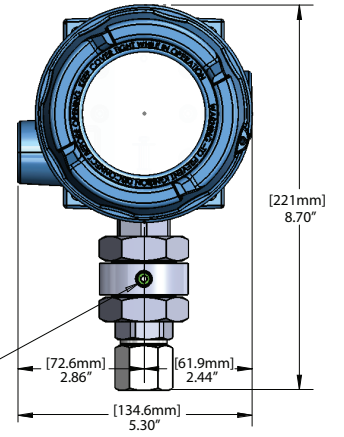

DUAL SEAL ENCLOSURE  
1/8" NPT ANNUNCIATION VENT CAN BE ROTATED UP TO 90° IN EITHER DIRECTION

## Temperature Sensors

### Fixed Local (TL1 - TL3)

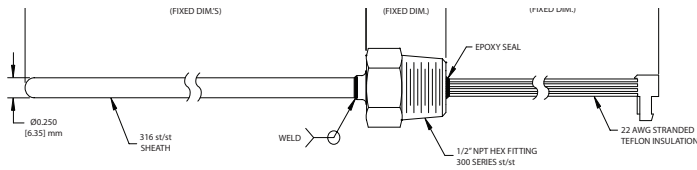

### Spring Loaded Local (TTC)

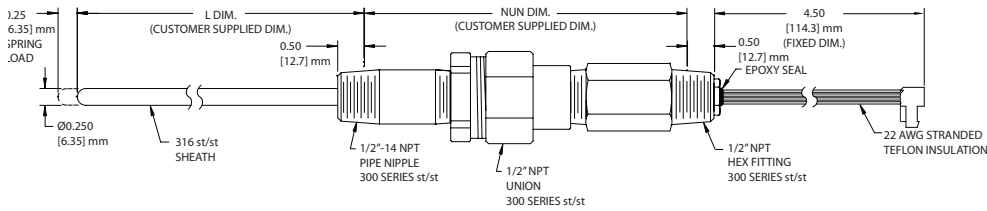

### Remote (TR1, TRC, TH1, THC, TC1, TCC)

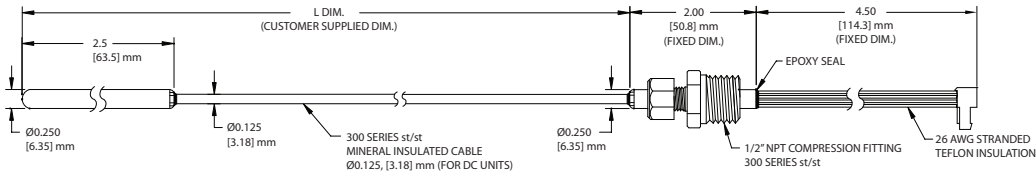

### Thermowell Adapter Kit Option W081 (UE Part #62169-44)

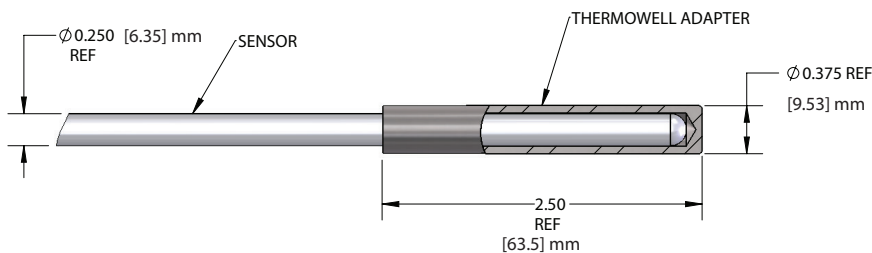

## FRENCH WARNING TRANSLATIONS

Page	Warning Text	Texte d'avertissement
1	Misuse of this product may cause explosion and personal injury. These instructions must be thoroughly read and understood before unit is installed. See the product nameplate information for specific agency certifications applicable to your product.	Utilisation abusive de ce produit peut causer une explosion et des blessures. Ces instructions doivent être soigneusement lues et comprises avant l'appareil est installé. Voir l'information sur la plaque signalétique du produit pour les certifications d'agence spécifiques applicables.
1	Substitution of components may impair suitability for use in hazardous locations. Cable glands used must be rated for a minimum of IP66 in order to maintain the same IP rating.	La substitution de composants peut nuire à l'aptitude à l'utilisation dans des endroits dangereux. Les presse-étoupes utilisés doivent avoir un indice de protection IP66 minimum afin de conserver le même indice de protection IP.
1	For zone hazardous locations, all cable entry devices shall be certified in type of explosion protection flameproof enclosure "d" with an IP66 rating suitable for the conditions of use and correctly installed. If cables and cable glands are not used, a stopping box shall be provided within 2" of the enclosure. Flameproof joint and gap details are provided on page 2.	Pour les zones explosives poussiéreuses, tous les dispositifs d'entrée de câble doivent être certifiés dans le type de protection de l'enceinte ignifuge "d" avec un indice de protection IP66, adapté aux conditions d'utilisation et correctement installés. Si les câbles et presse-étoupes ne sont pas utilisés, une boîte d'arrêt doit être fournie dans les 5 cm de l'enceinte. Plus de détails sont fournis à la page (2).
1	Install units where shock, vibration and temperature fluctuations are minimal. Orient unit to prevent moisture from entering enclosure. Use properly rated sealing fittings for electrical wire entry. Do not mount unit in ambient temperatures exceeding published limits. This is especially critical for local mount temperature units. Use of a shroud is recommended where direct sunlight and rain may come in contact with the enclosure.	Installez les unités où le choc, vibration et les fluctuations de température sont minimales. Orienter l'unité d'une manière à empêcher l'humidité de pénétrer dans l'enceinte. Utiliser des raccords d'étanchéité bien notés pour l'entrée de fil électrique. Ne pas monter l'unité à des températures ambiantes dépassant les limites publiées. Cela est particulièrement important pour les unités de température à montage locale. L'utilisation envelopper est recommandée lorsque le soleil et la pluie peuvent entrer en contact avec le boîtier.
3	Continuous operation should not exceed the designated over range pressure or working pressure range stated within the literature and on device nameplate.	Le fonctionnement continu ne doit pas dépasser la pression de dépassement ou la plage de pression de fonctionnement indiquée dans la documentation et sur la plaque signalétique de l'appareil.
4	Before installing, check the sensor model selected for compatibility to the process media in contact with the sensor and wetted parts.	Avant l'installation, vérifier le modèle de l'appareil sélectionné pour la compatibilité avec le fluide du procédé en contact avec le capteur et les parties mouillées.
4	In all applications, secure the enclosure as detailed below. Do not mount via the process connection only.	Dans toutes les applications, sécuriser l'enceinte comme détaillé ci-dessous. Ne pas installer par la connexion de processus seulement.
4	For pressure and local temperature models, always hold a wrench on the sensor housing hex when mounting the device. Do not tighten by turning the enclosure, as this will damage the connection between the sensor and housing.	Pour tous les modèles de température et pression locaux, toujours tenir une clé sur l'hexagone du capteur pendant le montage de l'unité. Ne pas serrer en tournant l'enceinte, cela pourrait endommager la connexion entre le capteur et l'enceinte.
4	For differential pressure models (especially low range units), mount the sensor level to minimize any pressure reading offsets. The offset command may be used to zero the display (see page xx for additional information).	Pour les modèles de pression différentielle (de pressions faibles), montez le niveau du capteur afin de minimiser tout décalage de lecture de pression. La commande décalée peut être utilisée pour mettre l'affichage à zéro (voir la page xx pour plus d'informations).
4	Never insert any object into the pressure sensor opening. Damage to the sensor will result, affecting accuracy.	Ne jamais insérer un objet dans l'orifice du capteur de pression. Les dommages à la membrane de capteur se traduira, à affecter la précision.

## FRENCH WARNING TRANSLATIONS CONT.

5	To prevent electrostatic discharge, wipe down cover and enclosure of any dust build-up before removing cover.	Pour éviter les décharges électrostatiques, nettoyez le capot et le boîtier de toute accumulation de poussière avant de retirer le capot.
5	Disconnect all supply circuits before wiring device. Wire device in accordance with local and national electrical codes. Maximum recommended wire size and recommended tightening torque for field wiring terminal blocks are shown within table 3 (page xx).	Débrancher tous les circuits d'alimentation avant de brancher l'appareil. Le câblage doit être effectuée selon les codes électriques nationaux et locaux. Tailles de fils recommandées maximales et couples de serrage pour le terrain câblage des borniers sont indiqués dans le tableau 3 (la page xx).
5	To prevent seizure of enclosure cover, do not remove lubricant. Threads should also be free of dirt and other contaminants.	Pour éviter le grippage du couvercle du boîtier, ne pas enlever le lubrifiant. Les fils doivent également être exempts de saleté et d'autres contaminants.
5	To prevent ignition, disconnect power before removing enclosure cover. Keep cover tight while in operation. Do not disconnect equipment unless power has been switched off or the area is known to non-hazardous.	Pour éviter l'inflammation, couper l'alimentation avant de retirer le couvercle du boîtier. Maintenir le couvercle fermé pendant le fonctionnement. Ne pas déconnecter l'équipement que lorsque l'alimentation est coupée ou que la zone est connue pour être non explosives.
5	Do not replace components unless power has been switched off or the area is known to be non-hazardous.	Ne remplacez pas les composants avant que le courant soit coupé ou que la zone est connue pour être non explosives.
5	The devices shall be properly grounded in the end use application using the ground screws provided with the enclosure.	Les appareils doivent être correctement mis à la terre en utilisant les vis de terre fournies avec l'enceinte.
5	Field wiring must be rated 105°C minimum. For ambient temperatures below -10°C, use suitable field wiring.	Câblage sur le terrain doit être évalué à 105°C minimum. Pour une température ambiante inférieure à -10°C, utiliser le câblage approprié.
5	Models 1XSWLL and 1XSWHL derive their power directly from a PLC/DCS discrete input or other low-current DC loads (see Figure 4-5, page xx). The switched output maximum load rating is 0.1A. The device must not be connected directly to a power supply without an appropriate current limiting load such as that provided by a PLC/DCS discrete input. Overloading the switch may cause failure (see Table 2).	Les modèles 1XSWLL et 1XSWHL sont directement alimentés par une entrée logique PLC / DCS ou par une autre charge continue à faible courant (voir la figure 4-5, page xx). La charge nominale maximale de la sortie commutée est de 0,1 A. L'appareil ne doit pas être connecté directement à une source d'alimentation sans une charge de limitation de courant appropriée telle que celle fournie par une entrée TOR PLC / DCS. Une surcharge du commutateur peut provoquer une panne (voir le tableau 2).
8	Do not connect model 1XSWLL directly to a power supply without a suitable load in series with the switch.	Ne connectez pas le modèle 1XSWLL directement à une source d'alimentation sans charge appropriée en série avec le commutateur.
8	Substitution of components may impair intrinsic safety.	La substitution de composants peut nuire à la sécurité intrinsèque.
12	Use of this option may create a condition where the display may indicate "0.00" when significant pressure or temperature (up to 10% of maximum range) exists in the system. Independent verification of the process variable should be done prior to maintenance on the system when "offset" appears on the display.	L'utilisation de cette option peut créer une condition dans laquelle l'écran peut indiquer «0,00» lorsqu'une pression ou une température significative (jusqu'à 10% de la plage maximale) existe dans le système. Une vérification indépendante de la variable de processus doit être effectuée avant la maintenance du système lorsque «offset» apparaît à l'écran.



## RECOMMENDED PRACTICES AND WARNINGS

United Electric Controls Company recommends careful consideration of the following factors when specifying and installing UE pressure and temperature units. Before installing a unit, the Installation and Maintenance instructions provided with unit must be read and understood.

- To avoid damaging unit, proof pressure and maximum temperature limits stated in literature and on nameplates must never be exceeded, even by surges in the system. Operation of the unit up to maximum pressure or temperature is acceptable on a limited basis (e.g., start-up, testing) but continuous operation must be restricted to the designated adjustable range. Excessive cycling at maximum pressure or temperature limits could reduce sensor life.
- A back-up unit is necessary for applications where damage to a primary unit could endanger life, limb or property. A high or low limit switch is necessary for applications where a dangerous runaway condition could result.
- The adjustable range must be selected so that incorrect, inadvertent or malicious setting at any range point cannot result in an unsafe system condition.
- Install unit where shock, vibration and ambient temperature fluctuations will not damage unit or affect operation. When applicable, orient unit so that moisture does not enter the enclosure via the electrical connection. When appropriate, this entry point should be sealed to prevent moisture entry.
- Unit must not be altered or modified after shipment. Consult UE if modification is necessary.
- Monitor operation to observe warning signs of possible damage to unit, such as drift in set point or faulty display. Check unit immediately.
- Preventative maintenance and periodic testing is necessary for critical applications where damage could endanger property or personnel.
- Electrical ratings stated in literature and on nameplate must not be exceeded. Overload on a switch can cause damage, even on the first cycle. Wire unit according to local and national electrical codes, using wire size recommended in installation sheet.
- Do not mount unit in ambient temp. exceeding published limits.

## LIMITED WARRANTY

Seller warrants that the product hereby purchased is, upon delivery, free from defects in material and workmanship and that any such product which is found to be defective in such workmanship or material will be repaired or replaced by Seller (Ex-works, Factory, Watertown, Massachusetts, INCOTERMS); provided, however, that this warranty applies only to equipment found to be so defective within a period of 24 months from the date of manufacture by the Seller (36 months for the Spectra 12 and One Series products; 18 months for Temperature Sensors). Seller shall not be obligated under this warranty for alleged defects which examination discloses are due to tampering, misuse, neglect, improper storage, and in any case where products are disassembled by anyone other than authorized Seller's representatives. EXCEPT FOR THE LIMITED WARRANTY OF REPAIR AND REPLACEMENT STATED ABOVE, SELLER DISCLAIMS ALL WARRANTIES WHATSOEVER WITH RESPECT TO THE PRODUCT, INCLUDING ALL IMPLIED WARRANTIES OF MERCHANTABILITY OR FITNESS FOR ANY PARTICULAR PURPOSE.

## LIMITATION OF SELLER'S LIABILITY

Seller's liability to Buyer for any loss or claim, including liability incurred in connection with (i) breach of any warranty whatsoever, expressed or implied, (ii) a breach of contract, (iii) a negligent act or acts (or negligent failure to act) committed by Seller, or (iv) an act for which strict liability will be imputed to seller, is limited to the "limited warranty" of repair and/or replacement as so stated in our warranty of product. In no event shall the Seller be liable for any special, indirect, consequential or other damages of a like general nature, including, without limitation, loss of profits or production, or loss or expenses of any nature incurred by the buyer or any third party.

UE specifications subject to change without notice.



UNITED ELECTRIC  
CONTROLS

180 Dexter Ave., Watertown, MA 02472-9143 USA

617 926-1000 Fax 617 926-2568

[www.ueonline.com](http://www.ueonline.com)

ECN #: 6476

CP08113000

Installation & Maintenance Instructions

# UE ONE SERIES

Electronic Pressure and Temperature HART Enabled  
Transmitter-Switch



Supplied by

**247able.com**

Call us on +44 (0)118 916 9420 | Email [info@247able.com](mailto:info@247able.com)



## One Series Electronic Pressure and Temperature HART Enabled Transmitter-Switch

Loop-Powered, Flameproof, and Non-Incendive Models: 1TXSW, 1TX00





UNITED ELECTRIC  
CONTROLS

## Installation and Maintenance Instructions

Please read all instructional literature carefully and thoroughly before starting. Refer to the final page for the listing of Recommended Practices, Liabilities and Warranties. All Warnings are translated to French and can be found of pages 24 and 25.

### GENERAL

 MISUSE OF THIS PRODUCT MAY CAUSE EXPLOSION AND PERSONAL INJURY. THESE INSTRUCTIONS MUST BE THOROUGHLY READ AND UNDERSTOOD BEFORE UNIT IS INSTALLED. SEE THE PRODUCT NAMEPLATE INFORMATION FOR SPECIFIC AGENCY CERTIFICATIONS APPLICABLE TO YOUR PRODUCT.

 SUBSTITUTION OF COMPONENTS MAY IMPAIR SUITABILITY FOR USE IN HAZARDOUS LOCATIONS. CABLE GLANDS USED MUST BE RATED FOR A MINIMUM OF IP66 IN ORDER TO MAINTAIN THE SAME IP RATING.

 FOR ZONE HAZARDOUS LOCATIONS, ALL CABLE ENTRY DEVICES SHALL BE CERTIFIED IN TYPE OF EXPLOSION PROTECTION FLAMEPROOF ENCLOSURE "d" WITH AN IP66 RATING, SUITABLE FOR THE CONDITIONS OF USE AND CORRECTLY INSTALLED. IF CABLES AND CABLE GLANDS ARE NOT USED, A STOPPING BOX SHALL BE PROVIDED WITHIN 2" OF THE ENCLOSURE. FLAMEPROOF JOINT AND GAP DETAILS ARE PROVIDED ON PAGE 2.

 INSTALL UNITS WHERE SHOCK, VIBRATION AND TEMPERATURE FLUCTUATIONS ARE MINIMAL. ORIENT UNIT TO PREVENT MOISTURE FROM ENTERING ENCLOSURE. USE PROPERLY RATED SEALING FITTINGS FOR ELECTRICAL WIRE ENTRY. DO NOT MOUNT UNIT IN AMBIENT TEMPERATURES EXCEEDING PUBLISHED LIMITS. THIS IS ESPECIALLY CRITICAL FOR LOCAL MOUNT TEMPERATURE UNITS. USE OF A SHROUD IS RECOMMENDED WHERE DIRECT SUNLIGHT AND RAIN MAY COME IN CONTACT WITH THE ENCLOSURE.

**DURING INSTALLATION, MARK THE BOX NEXT TO EACH PROTECTION METHOD ON THE NAMEPLATE THAT APPLIES TO YOUR APPLICATION.**

Table 1

**THIS EQUIPMENT IS CERTIFIED IN ACCORDANCE WITH THE REQUIREMENTS OF THE FOLLOWING APPLICABLE STANDARDS (SEE TABLE 1) AND IS SUITABLE FOR USE IN NON-HAZARDOUS AND THE FOLLOWING HAZARDOUS LOCATIONS, AND IS ATEX AND IECEx CERTIFIED SUITABLE FOR APPROPRIATE USE IN GAS AND DUST ZONE 1 APPLICATIONS.**

Model 1TXSW, 1TX00	N. America	Europe	International
Flameproof			
Cert Number:	Report Reference: #26592-20150623	DEMKO 09 ATEX 0813748X	IECEx UL 08.0017X
Applicable Standards	UL 1203, UL 60079-0, UL 60079-1, UL 61010-1, UL 50, UL 50E, CSA C22.2 No. 25, CSA C22.2 No. 60079-0, CSA C22.2 No. 60079-1, CSA C22.2 No. 61010-1, CSA C22.2 No. 94.1, CSA C22.2 No. 94.2, CSA C22.2 No. 30	EN 60079-0 EN 60079-1 EN 60079-31	IEC 60079-0 IEC 60079-1 IEC 60079-31
Suitable for appropriate use in:	Class I, Div. 1, Groups A, B, C & D Class II, Div. 1 Groups E, F & G Class III Class I, Zone 1 AEx db IIC T3/T5* Ex d IIC T3/T5*	II 2 G Ex db IIC T3/T5* Gb II 2 D Ex tb IIIC T90°C Db IP66 -40°C ≤ TAMB ≤ +80°C	Ex db IIC T3/T5* Gb Ex tb IIIC T90°C Db IP66 -40°C ≤ TAMB ≤ +80°C
Non-Incendive			
	N. America	Europe	International
Cert number:	Report Reference: #26592-20150623	DEMKO 15 ATEX 1483	IECEx UL 08.0017X
Applicable Standards	UL-60079-0, UL 60079-15, ISA 12.12.01, CSA C22.2 No. 213, CSA C22.2 No. 60079-0:11, CSA C22.2 No. 60079-15:12, CSA C22.2 No. 157-92	EN 60079-0 EN 60079-15	IEC 60079-0 IEC 60079-15

## FLAMEPROOF - SPECIAL CONDITIONS FOR SAFE USE

- Field wiring must be rated 105°C minimum. For ambient temperatures below -10°C, use suitable field wiring.
- Blanking elements from factory have been tested for flameproof “d” and dust “tb” with the enclosure as an assembly and carry no markings.
- A suitable thermowell made from corrosion-resistant material and engaging 5 threads minimum (with thread sealant) is required for the local spring loaded temperature sensor to maintain IP66

### Flameproof joint and gap details

- Enclosure to cover threaded joint: 4”-16 UN-2, 7 threads engaged minimum
- Glass to cover cemented joint: 0.753” (19.1 mm) rabbet/spigot minimum length
- Breather element threaded joint: M8-1.25 (6g/6H medium fit class), 11 threads engaged minimum
- Electrical conduit threaded joint: 3/4”-14 NPT, 5 threads engaged minimum
- Enclosure to sensor threaded joint:
  - Pressure models: 1”-20 UNEF-2, 10 threads engaged minimum
  - Temperature models: 1/2”-14 NPT, 5 threads engaged minimum
  - Remote and local spring loaded temperature sensor gap joints: 0.0045” (0.114 mm) maximum annular gap by 1.25” (31.8 mm) minimum length
- The device must be cleaned with a damp cloth to avoid static discharge.

### Dual Seal Adaptor (Option M041)

- Threaded Dual Seal Adaptor Option Enclosure to One Series Enclosure: 1”-20 UNEF-2, 10 threads engaged minimum
- Breather element threaded joint: 1/4”-20 UNC-2, 10 threads engaged minimum
- Secondary Seal Housing to union housing joint: 0.580” (14.73 mm) rabbet/spigot minimum length, maximum annular gap 0.003” (0.08 mm)
- Sensor to union housing joint: 0.580” (14.73 mm) rabbet/spigot minimum length, maximum gap 0.003” (0.08 mm)
- Threaded Dual Seal Adaptor option to Sensor: 1”-20 UNEF-2, 10 threads engaged minimum or 1/2”-14 NPT 5 threads engaged minimum.



CONTINUOUS OPERATION SHOULD NOT EXCEED THE DESIGNATED OVER RANGE PRESSURE OR MAXIMUM WORKING PRESSURE STATED WITHIN THE LITERATURE AND ON DEVICE NAMEPLATE.

Over Range Pressure: The maximum pressure to which a pressure sensor may be continuously subjected without cause damage and maintaining set point repeatability.

Max Working Pressure: The maximum that can be applied to both process ports simultaneously without affecting sensor performance.

The One Series transmitter-switch product line is based on an all-solid-state electronic module that incorporates a microprocessor. The combination of features like no moving parts and IAW® self-diagnostics provide a highly reliable, accurate and repeatable monitor for detecting pressure and temperature thresholds which once reached, can make intelligent switch decisions based upon retained settings and current conditions. The One Series monitors its own health and reports the status locally through the IAW® (I Am Working) feature that provides a solution to the “blind device” issue common with mechanical switches. You will always know the health status of the One Series.

The One Series 1XTXSW and 1XTX00 models include a standard 4-20 mA output with HART® version 7 protocol for control of all transmitter and switching functions. The IAW® self-diagnostics feature combined with the NAMUR NE 43 standard provides an additional method of remotely reporting detected faults. By monitoring the local display or either of the two fail-safe relays or the fail-safe-open IAW® OUTPUT or the 4-20 mA signal, the One Series offers several and redundant methods of fault reporting.



The One Series is also very rugged, featuring a Type 4X, weather-tight enclosure suitable for harsh environments and hazardous (Class I, Division 1) locations. The 0.5% accuracy rating is maintained over a very wide -40°C to +70°C operating range using active temperature compensation. Repeatability rivals that of a process transmitter, with a 0.1% of full range while the switches set point and deadband (hysteresis) are fully programmable over the entire range of the sensor. Reaction time for the One Series to a process change is typically 100 mS or less.

### I Am Working (IAW™)

The One Series also contains UE's patented IAW® self-diagnostic software. On a continuous basis, the IAW® algorithm checks for proper operation, and locally reports the status using messages or revolving arrows on the display. For remote reporting, a discrete IAW® output signal can be monitored by the control system and used to detect normal, tripped, and fault conditions. IAW® self-monitors, searching for possible faults, both within the instrument and in the overall system (a list of the various fault codes is outlined in table 4, page 19). In the event of a detected fault, the One Series will attempt to display the fault details and provide remote electrical indication by opening (turning off) the IAW® Output. In the case of certain micro-controller faults, the revolving arrow may freeze or go out; indicating locally that a failure exists.

## DISPLAY FEATURES AND DIAGNOSTICS

The One Series features a large, easy to read LCD display (See Figure 1). It is used for three main purposes: process indication, programming and switch status/troubleshooting.



Figure 1

In the Process Display mode, the display may be indicating the following:

- Current process value and units of measure: A value will be displayed as long as the reading is within 110% of the full scale range noted on the nameplate.
- I Am Working (IAW®) status: When the unit is working properly, a circular 4-segment arrow will be revolving around the letters "IAW" in the top center of the display.
- Offset/Span Adjustment: The word "offset" will appear above the process value, indicating that the factory offset and/or span calibration has been modified by the user.

In addition, the user can easily access information such as the set point, deadband and minimum/maximum process readings:

By pushing the right → button once, the display will scroll as follows:

SP1 XX.XX DB1 XX.XX SP2 XX.XX DB2 XX.XX

By pushing the left ↓ button once, the display will scroll the min/max process values recorded in memory:

MAX XX.XX MIN XX.XX

The display will automatically revert back to the Process Display mode after scrolling.

### ALARM CONDITION

When the process goes beyond the set point, the display will begin to flash, alternating between the process value and "SW1/SW2". The display will continue to flash until the process has returned to a value beyond the deadband, at which point the display will revert to normal operation and process value display. If the unit was programmed to have a latching output, a small "Latch" icon will light in the display when the set point is reached, indicating that the output is latched and needs to be manually reset.

### FAULT CONDITIONS

In the case of a fault condition, the display may indicate the following:

If the IAW® software detects a fault outside of the micro-controller, and can still operate, it will display an error message.

If it is a failure of the power supply or the wiring, the display will go blank.

(See Fault Codes Table 4, page 19 for a complete description of fault diagnostics.)

Please refer to the product technical brochure for product specifications. Product technical brochure may be found at [www.ueonline.com](http://www.ueonline.com).

UE declarations and third party issued certifications are available for download at [www.ueonline.com/support/certifications/](http://www.ueonline.com/support/certifications/).

Date code format on nameplate is "YYWW" for year and week (see Figure 16, Page 20)

## PART I - MOUNTING

## FLAMEPROOF AND NON-INCENDIVE - MOUNTING

**Tools Required:** Screwdriver for mounting bolts; 4 mounting bolts (1/4" Max.)

**NOTE:** For optional surface and pipe mounting kit, order part no. 6361-704. See page 22.



BEFORE INSTALLING, CHECK THE SENSOR MODEL SELECTED FOR COMPATIBILITY TO THE PROCESS MEDIA IN CONTACT WITH THE SENSOR AND WETTED PARTS.



IN ALL APPLICATIONS, SECURE THE ENCLOSURE AS DETAILED BELOW. DO NOT MOUNT VIA THE PROCESS CONNECTION ONLY.

Mount the device using the four (4) 1/4" clearance holes in the enclosure base. Plumb sensor to the process port. See page 23 for dimensions.

The device may be mounted in any position except with the sensor connection facing up. Ensure the process connection is sealed to the process port to prevent leakage. Care should be taken to minimize effects of shock and vibration. The One Series should be protected from direct sunlight and rain in outdoor installations using a shroud (user supplied).

**NOTE:** the optimal display viewing position is 6:00.



FOR PRESSURE AND LOCAL TEMPERATURE MODELS ALWAYS HOLD A WRENCH ON THE SENSOR HOUSING HEX WHEN MOUNTING DEVICE. DO NOT TIGHTEN BY TURNING ENCLOSURE, THIS WILL DAMAGE THE CONNECTION BETWEEN THE SENSOR AND HOUSING.



FOR DIFFERENTIAL PRESSURE MODELS (ESPECIALLY LOW RANGE MODELS), MOUNT THE SENSOR LEVEL TO MINIMIZE ANY PRESSURE READING OFFSETS. THE OFFSET COMMAND MAY BE USED TO ZERO THE DISPLAY, (SEE PAGE 13 FOR ADDITIONAL INFORMATION).

## PROCESS CONNECTIONS AND SENSOR FOR FLAMEPROOF AND NON-INCENDIVE INSTALLATIONS



NEVER INSERT ANY OBJECT INTO THE PRESSURE SENSOR OPENING. DAMAGE TO THE SENSOR WILL RESULT, AFFECTING ACCURACY.

### Pressure and Differential Pressure Models

To pipe mount: Thread the pressure connection onto the pressure port, with thread sealant, making sure that the mating threads are clean and free of debris. Use a wrench on the pressure connection hex to tighten. Test for leaks. On Differential Pressure models, the Low (L) side pressure must NOT exceed the high (H) side pressure. Damage to the sensor may result.

### Local and Remote Temperature Models

For Local Ambient Sensing (model L): Mount using the mounting holes on the electronics housing. Mount the device to ensure that the sensor housing will not be damaged and where the measured temperature is representative of the surrounding environment.

For Local Spring-Loaded (model T): A suitable thermowell, made from corrosion-resistant material, 5 threads engaged minimum, with thread sealant, is required to maintain enclosure type 4X/IP66.

For Remote Sensing: Route the extension wire to avoid contact with live components or close proximity to electrical noise sources. Avoid kinks, or excessive flexing. Tighten the ferrule fitting, if applicable.

For Surface Sensing: Secure the sensor housing to the pipe or vessel using an adhesive or strapping method suitable for the application.

For Immersion Sensing (models C, H, R & L): Use of a thermowell is highly recommended to aid in maintenance, testing and preservation of the system integrity. Insert the sensor housing (0.25" diameter) into the well ensuring that the sensor's sheath bottoms out and the well is completely immersed in the media (2.5" min.) Screw the sensor's nipple into the thermowell, with thread sealant, by placing a wrench on the union nut. Tighten the union connector.

For best temperature measurements, the sensor housing must be in full contact with the surface or media being measured. Heat transfer compound may be used to aid in fully transferring the media temperature to the sensor housing. Locate where the temperature is most representative of the system. Minimum insertion depth is 2-1/2". Sensor dimensional drawings are shown on page 23.



## PART II - WIRING

### Removing the One Series Enclosure Cover and Display Module



TO PREVENT ELECTROSTATIC DISCHARGE WIPE DOWN COVER AND ENCLOSURE OF ANY DUST BUILD-UP BEFORE REMOVING COVER.



DISCONNECT ALL SUPPLY CIRCUITS BEFORE WIRING DEVICE. WIRE DEVICE IN ACCORDANCE WITH LOCAL AND NATIONAL ELECTRICAL CODES. MAXIMUM RECOMMENDED WIRE SIZE AND RECOMMENDED TIGHTENING TORQUE FOR FIELD WIRING TERMINAL BLOCKS ARE SHOWN WITHIN TABLE 2 (PAGE 5).



TO PREVENT SEIZURE OF ENCLOSURE COVER, DO NOT REMOVE LUBRICANT. THREADS SHOULD ALSO BE FREE OF DIRT AND OTHER CONTAMINANTS.

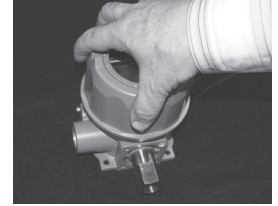

Figure 2

Remove the enclosure cover by turning it counter-clockwise for 7 revolutions (Figure 2). Carefully remove the display module by grasping the outer edge and pulling it away from the base enclosure (Figure 3), being careful not to strain any of the wired connections. Allow the display module to hang from the wired connections to access the base enclosure and terminal blocks for wiring. Do not remove the display module wire assemblies. Insert the field wiring through the conduit opening(s) of the base enclosure. Make the connections as shown within the wiring diagrams (Figure 4-5, page 6). The primary chassis and equipment grounding terminal is provided inside the base enclosure.



Figure 3

Cleaning the display and keypad surface should be performed with a damp cloth only. Do not attempt to wash down the One Series with the cover removed.

### WIRING FOR FLAMEPROOF & NON-INCENDIVE INSTALLATIONS

**Tools Required:** Small flat-head screwdriver; wire strippers



TO PREVENT IGNITION, DISCONNECT POWER BEFORE REMOVING ENCLOSURE COVER. KEEP COVER TIGHT WHILE IN OPERATION. DO NOT DISCONNECT EQUIPMENT UNLESS POWER HAS BEEN SWITCHED OFF OR THE AREA IS KNOWN TO BE NON-HAZARDOUS.



DO NOT REPLACE COMPONENTS UNLESS POWER HAS BEEN SWITCHED OFF OR THE AREA IS KNOWN TO BE NON-HAZARDOUS.



THE DEVICES SHALL BE PROPERLY GROUNDED IN THE END USE APPLICATION USING THE GROUND SCREWS PROVIDED WITH THE ENCLOSURE.



FIELD WIRING MUST BE RATED 105°C MINIMUM. FOR AMBIENT TEMPERATURES BELOW -10°C, USE SUITABLE FIELD WIRING.

### Terminal Block and Torque Details

	Description	Max. Wire Gauge	Min. Wire Gauge	Recommended Tightening Torque
TB1	3-Position	14 AWG	22 AWG	3.48 in-lbs. or 0.39 Nm
TB2*	4-Position	14 AWG	26 AWG	4.4 in-lbs. or .50 Nm <small>Table 2</small>
TB3*	2-Position	14 AWG	26 AWG	4.4 in-lbs. or .50 Nm

**NOTE:** The sensor's 4-conductor ribbon cable assembly must remain connected to the display module with the red wire oriented to the arrow on the label at the rear of the module. Reversing this connector will result in measurement errors or failure. Please refer to the wiring diagrams beginning on page 6. \*Model 1XTXSW only

## WIRING DIAGRAMS

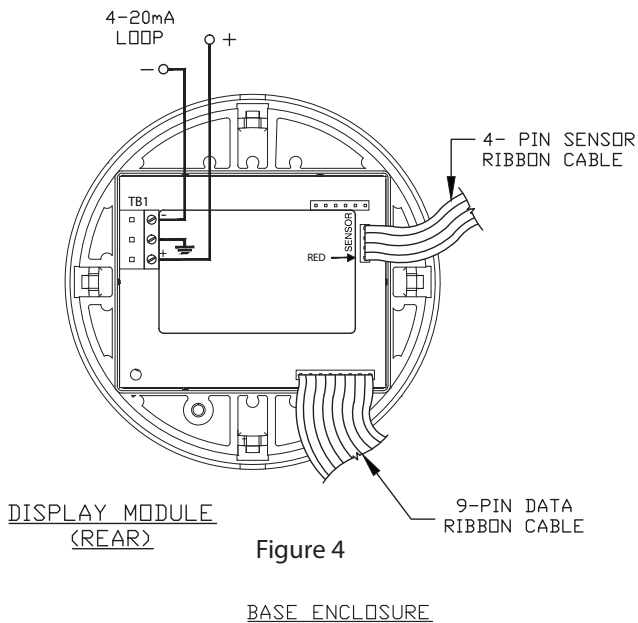

Figure 4

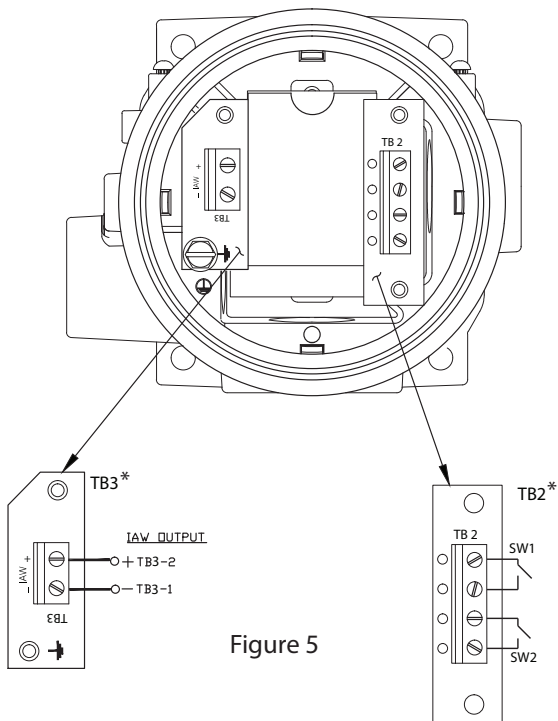

Figure 5

The One Series enclosure includes two conduit openings, one intended for the high-power switch wiring and the other intended for low-level signal and analog 4-20 mA wiring. 4-20 mA signals shall be wired using a shielded/twisted pair to minimize the effects of electrical interference. Please follow local electrical code requirements for explosion/flame proof instrumentation.

Figures 4, 6, & 7 provide a rear view of the display module after it has been removed from the base enclosure and an inside view of the base enclosure circuit boards. Terminal Block 1 (TB1) is located on the display module. Terminal blocks TB2 & TB3 are located inside the base enclosure.\*

Models 1XTXSW and 1XTX00 are loop-powered and are normally connected directly to an analog input of a PLC or DCS via TB1 providing a 4-20 mA analog signal, repeating the pressure or temperature process variable (see Figure 6, Page 7). Polarity must be observed. This loop connection powers the entire One Series, including the actuation of both solid-state relays (SW1 & SW2) and the IAW<sup>®</sup> OUTPUT signal. The bi-directional relays are connected via TB2 and are intended to switch external loads. IAW<sup>®</sup> OUTPUT is a discrete signal for providing health status to a control system and is connected via TB3 and polarity must be observed. Connections to the relays and the health status signal are optional (not required).\*

**NOTE:** As an alternative to loop power, model 1XTXSW may be wired directly to a 24 VDC power supply (+) and minus (-) terminals (see Figure 7, Page 7). In this wiring configuration, power is provided for all switching and diagnostic functions but the 4-20 mA analog output is not used. The digital display will provide the process variable. This alternative method of powering the One Series may be used when loop power is not available and a 4-20 mA output is not desired.

An additional discrete signal is available at TB3-1 & TB3-2. IAW<sup>®</sup> OUTPUT is intended for monitoring the health status of the One Series by connecting it to a logic solver input. This output may also be used to distinguish between a process upset (set point

### Maximum Switch Ratings

Signal Name	Location	Voltage Ratings	Current Ratings
SW1	TB2 (no polarity)	0 – 280 VAC and VDC	0.3 amperes <sup>1</sup>
SW2	TB2 (no polarity)	0 – 280 VAC and VDC	0.3 amperes <sup>1</sup>
IAW <sup>®</sup> OUTPUT	TB3-2 (+) & TB3-1 (-)	0 – 30 VDC	0.020 amperes

<sup>1</sup>Derate 8% per 10 °C above 21°C

\*Model 1XTXSW Only

Table 3

## Power Options

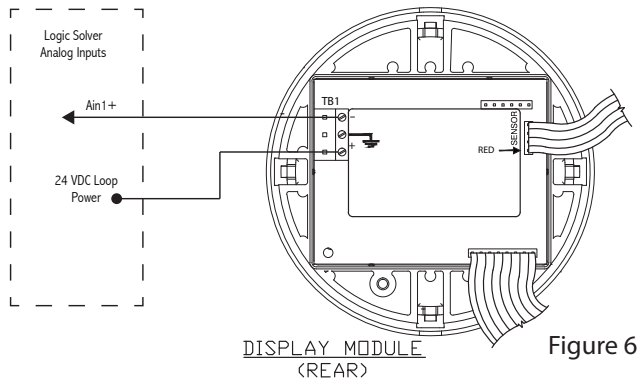

Figure 6

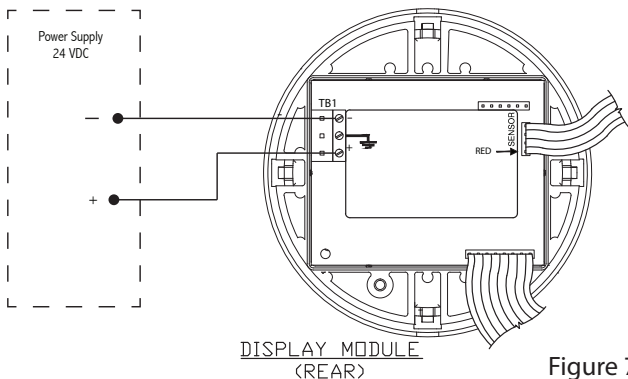

Figure 7

The One Series may be powered from the analog loop current power supply (like most transmitters) using only 2 wires. This configuration provides a digital displaying 4-20 mA output transmitter. The process variable and diagnostic information is available on the display. All device functions, including SW1, SW2 and IAW<sup>®</sup> OUTPUT are powered by the loop current power supply and require additional wiring, if used. Refer to the Wiring example (see Figure 8) for more information.

The One Series may also be powered by direct connection to a 20 – 40 VDC power supply. All device functions, including SW1, SW2 and IAW<sup>™</sup> OUTPUT are powered. In this configuration, the analog 4-20 mA output is disabled. Refer to the Wiring example (see Figure 8) for additional wiring methods.

**NOTE:** A series resistor is required for supply voltages above 24VDC. See Table 4 on page 9.

## Wiring Example\*

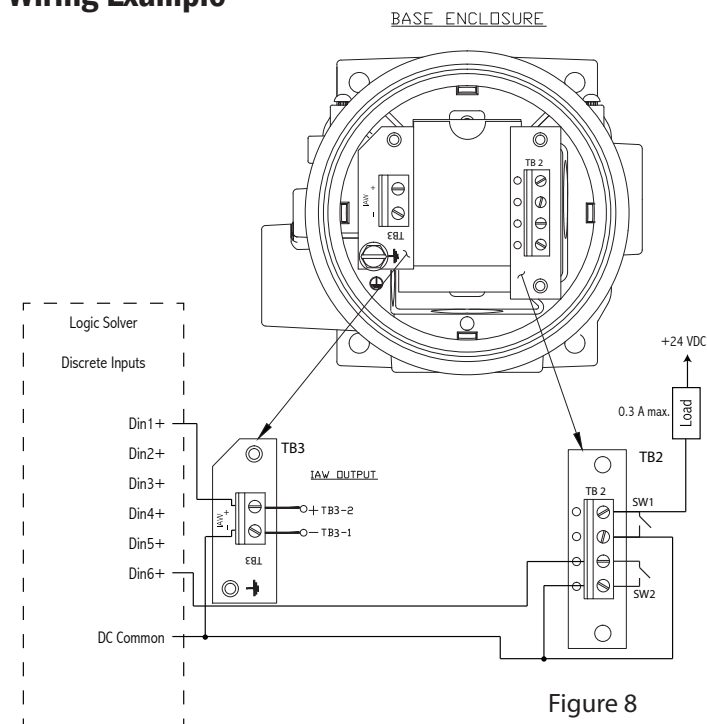

Figure 8

This diagram provides an example wiring scheme for SW1, SW2 and IAW<sup>®</sup> OUTPUT switches.

- SW1 is connected to an external load, providing a means to switch a local device (e.g., lamp, horn, etc.) to provide a warning that the high limit set point has been reached.
- SW2 is connected to a logic solver discrete input (Din6) for remote monitoring of the high-high set point to initiate a shutdown.
- IAW<sup>®</sup> OUTPUT is connected to logic solver discrete input (Din1) for remote monitoring of the One Series diagnostics. This normally-closed switch will open if a fault is detected.

**NOTE:** All switches in this wiring example are connected to DC Common but can be separated to maintain power supply isolation. SW1 and SW2 are independently configurable for open, close and window modes on rising or falling media. Wiring

## HART® WIRING AND OPERATION

No separate wiring is required for digital communication with HART® devices since the HART® FSK (Frequency Shift Keying) signal is superimposed on top of the 4-20 mA output signal. Digital data is sent to and from the One Series via a HART® communicator while real-time process information is available via the 4-20 mA signal. A twisted pair or shielded wire cable is recommended where extended lengths are required or electrical noise may be present.

For Bench Testing, connect the One Series to a power supply and a load resistor (see Figure 10). A voltmeter across the 250 Ω resistor can be used to measure the current in the loop ( $I_{loop} = V_{resistor} / 250$ ). At 4 mA the voltmeter will read 1 volt and at 20 mA the meter will read 5 volts.

For Field Operation, the One Series can be connected to any HART® compatible input card, module or, if the HART® interface is not being used, any standard 4-20mA input (see Figure 9). In most cases the power supply and the load resistor are built into the input card or module, allowing direct connect with no external load resistor.

**NOTE:** Before attempting to change the polling address, UE recommends installing the One Series device descriptions (DDs) on your handheld or software application. Installation instructions for Device Descriptions (DD) as well as DD files may be found at [www.ueonline.com/products/hazardous-location/one-series/](http://www.ueonline.com/products/hazardous-location/one-series/) under HART® Protocol Resources. Once the DDs have been properly installed, the One Series can be fully accessed and is ready to receive the Universal, Common Practice and Device Specific commands that can be found within table 5, page 17-18 of this manual.

By default, the polling address of the One Series 1XTX is set to "0". To be accessible through a HART® network with multiple HART® devices, the One Series must be in multi-drop mode by setting the polling address to a number other than "0". The polling address can be changed by using a HART® Handheld Communicator or HART® modem and software to any value between 1 and 63. Choose an address that is not being used by another device in the HART® network.

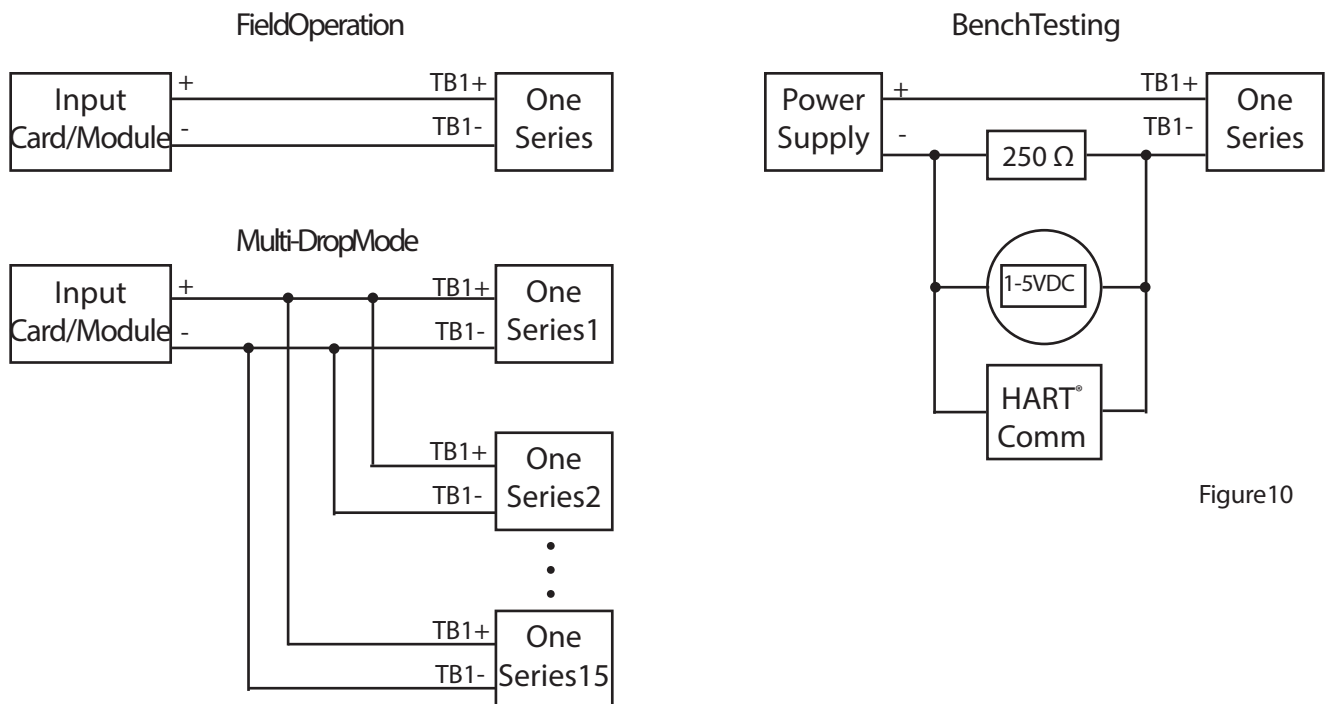

Figure 10

Figure 9

# ONE SERIES 4-20mA POWER SUPPLY AND LOAD LIMITS

V <sub>in</sub>	R <sub>min</sub>	R <sub>max</sub>
20	0.0	181.8
21	0.0	227.3
22	0.0	272.7
23	0.0	318.2
24	0.0	363.6
25	47.6	409.1
26	95.2	454.5
27	142.9	500.0
28	190.5	545.5
29	238.1	590.9
30	285.7	636.4

V <sub>in</sub>	R <sub>min</sub>	R <sub>max</sub>
31	333.3	681.8
32	381.0	727.3
33	428.6	772.7
34	476.2	818.2
35	523.8	863.6
36	571.4	909.1
37	619.0	945.5
38	666.7	1000.0
39	714.3	1045.5
40	761.9	1090.9

Table 4

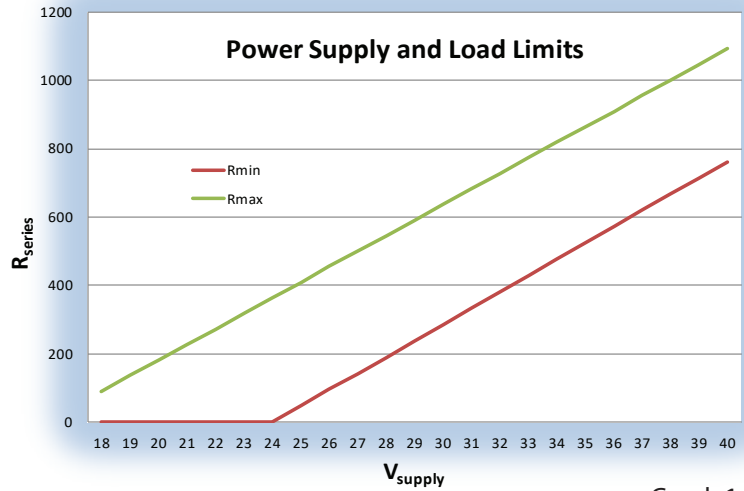

Graph 1

## FAULT CURRENT

A diagnostic fault will force the IAW® Output to the fail safe state and the SW1 and SW2 relays to the as-configured tripped state. In addition to the discrete outputs, the One Series includes a NAMUR NE 43 standard 4-20 mA output that outputs  $\leq 3.6$  mA in a fault condition.

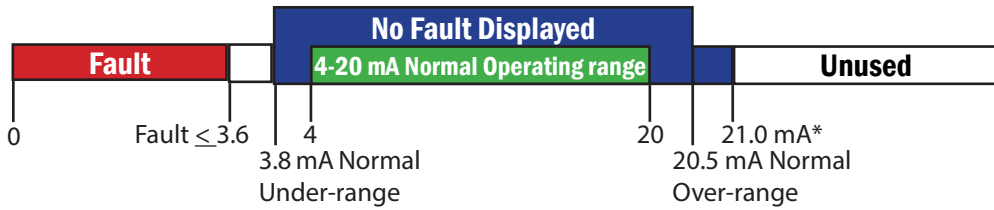

\*21.0 mA only when the temperature sensor is subject to 103.25% to 110% of range or when the pressure sensor is subject to 103.25% to 150% of range.

Figure11

## PART III - PROGRAMMING

### Basic Programming

**Tools Required:** Programming Flowchart (see Flowchart 1, page 21)

Programming of the One Series is accomplished using the two buttons on the faceplate (labeled ↓ and → see Figure 12). Stepping down through the main menu using the left ↓ button, you can access the various commands of the One Series software menu. The right button is then used to move into the command submenu for setting up or modifying the parameters.

**NOTE:** The flowchart on page 21 shows the entire programming commands menu structure. Before removing the enclosure cover, please read the instructions on page 5. The One Series programming menu is a single direction loop, with submenus embedded within, so there is no way to back up in the program. If you need to make a correction to a prior Main Menu step, you will need to continue forward, exit, then re-enter the program to step through to the appropriate feature. If you are in a Submenu, you will need to continue to the beginning of the menu item and re-enter the Submenu to make the correction.

#### Entering the Programming Mode

**NOTE:** While in the Programming Mode, the One Series will remove itself from service (go offline). All outputs are set to the fail safe state and the One Series ignores process variable input from the process sensor. The IAW® Output signal will open. The switch output failsafe state will be based on the programmed operating mode of the switch. For example, the failsafe state for “Open on” modes is open. The control system will interpret these signals as a detected fault and a process upset (set point reached) simultaneously. **It is essential to alert the control system operators before entering the Programming Mode.**

Use the Flowchart on page 21 as a guide through the various commands in the Programming Mode.

- Press and release both buttons ↓→ simultaneously and then press the right button → to enter the password.
- Enter the 4-digit password. The factory default password is “0000”.
  - The left ↓ button increments the blinking digit.
  - The right → button sets the digit and moves to the next.
  - Once a valid password is entered, “OK” will appear on the display.
- Press and release the right → button.
  - CLR MAX/MIN (or MAN RSET if Latch is set) will appear on the display.

This is the first command prompt in the Programming Mode.

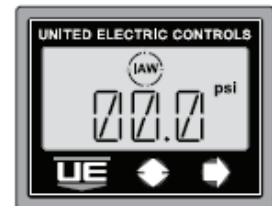

Figure 12

**NOTE:** The One Series will automatically exit the Programming Mode and resume monitoring the process (go back online) if two minutes elapse without a button being pressed. The One Series recalls all previously saved parameters from memory and any program changes that were made will be discarded. This two-minute time-out feature prevents the One Series from being left offline accidentally.

#### Exiting the Programming Mode

When any of the programming commands are displayed, it is possible to escape and exit the Programming Mode by pressing the left ↓ and right → button simultaneously. Doing this redirects the program to the Save Changes menu location, which is only possible at menu actions indicated by an asterisk (\*) on the Programming Flowchart, found on page 21.

**NOTE:** It is also possible to exit the Programming Mode by repeatedly pressing the left ↓ button from any programming command until the Save Changes menu location is reached.

#### Saving Programming Changes

When changes have been made to the programming settings, a choice is provided to Save or Discard the changes.

At any prompt:

- Press both left ↓ and right → buttons to display SAVE CHNG menu.

To Save changes, press the right → button. NO (the default) will be displayed.

- Press the left ↓ button to toggle and display YES.
- Then press both left ↓ and right → buttons to confirm, save the changes and return to the Process Display



mode.

The One Series will resume process monitoring (go back online) using the new programming parameters.

To Discard changes, press the right → button. NO will be displayed.

- Press both left ↓ and right → buttons to confirm, discard changes and return to the Process Display mode. The One Series will resume monitoring the process (go back online) recalling all previously saved parameters from memory.

## BASIC FEATURES

### Setting the Units of Measure

The One Series allows the units of measure to be set in the field. The default units are pounds per square inch (PSI) for pressure models and degrees Fahrenheit (°F) for temperature models.

- To change the units of measure, enter the programming mode. Press the left ↓ button. The display will scroll SET UNITS. Press the right → button and the display will read the default units psi or °F.
- Repeatedly press and release the left ↓ button to select from the available choices. Stop at the desired choice.
- Press the right → button to make the selection. The display will return to “Set Units.”
- Press the left ↓ button to continue on in the menu or press both left ↓ and right → buttons to exit the Programming Mode and save changes.

**NOTE:** MAX/MIN memory is reset (changed to zero) whenever the units of measure have been changed. Set Point, Deadband, Offset, Span and Plug Port values are recalculated for the newly selected units of measure.

### Setting the Switch Mode, Set Point and Deadband for SW1 and SW2 (1TXSW Only)

Please refer to the Programming Flowchart, page 21. Repeat these steps for SW2.

- Enter the programming mode (see page 10).
- Press and release the left ↓ button until SW1 appears on the display.
- Press the right → button. The previously selected mode will appear. OPEN RISE is the factory default.

**NOTE:** The One Series has six available modes of operation

OPEN RISE - Switch opens on rising process values that exceed the set point.

OPEN FALL - Switch opens on falling process values that drop below the set point

OPEN WINDOW - Switch opens when process values go outside configured limits specified by set point high and set point low.

CLOSE RISE - Switch closes on rising process values that exceed the set point.

CLOSE FALL - Switch closes on falling process values that drop below the set point.

CLOSE WINDOW - Switch closes when process values go outside configured limits specified by set point high and set point low.

Please use the Switch Decision Logic (Figure 13, page 12) for help with setting the appropriate switch mode.

- Press and release the left ↓ button until the desired mode appears.
- Press the right → button to select the mode and move on to the set point. SP will appear.

**NOTE:** The set point is the process value at which the One Series opens or closes the SW1 and SW2 switch. The Set Point is fully programmable throughout the operating range of the sensor as noted on the device nameplate.

- Press the right → button to select a positive or negative set point. POS is the default. Use the left ↓ button to change to NEG.
- Press the right → button to view and change the set point. Press the left ↓ button to increment the blinking digit. Press the right → button to enter and move to the next digit.
- Press the right → button to enter a new Deadband. DB will show on the display.

**NOTE:** The Deadband is the amount above or below the set point at which the One Series resets the SW1 and SW2 switch, returning it to the normally closed or open state. Deadband is represented as a value which is

added or subtracted from set point, depending on the control mode.

- Example 1: If the Control Mode is OPEN RISE and the set point is 100 and the deadband is 10, the Switch will open as pressure rises to 100 and close (reset) as the pressure falls to 90.
- Example 2: If the Control Mode is CLOSE RISE and the set point is 100 and the deadband is 10, the Switch will close as pressure rises to 100 and open (reset) as the pressure falls to 90.
- Example 3: If the Control Mode is OPEN FALL and the set point is 100 psi and the deadband is 10, the Switch will open as pressure falls to 100 psi and close (reset) as pressure rises to 110 psi. Example 4: If the Control Mode is CLOSE FALL and the set point is 100 psi and the deadband is 10, the Switch will close as pressure falls to 100 psi and open (reset) as pressure rises to 110 psi.

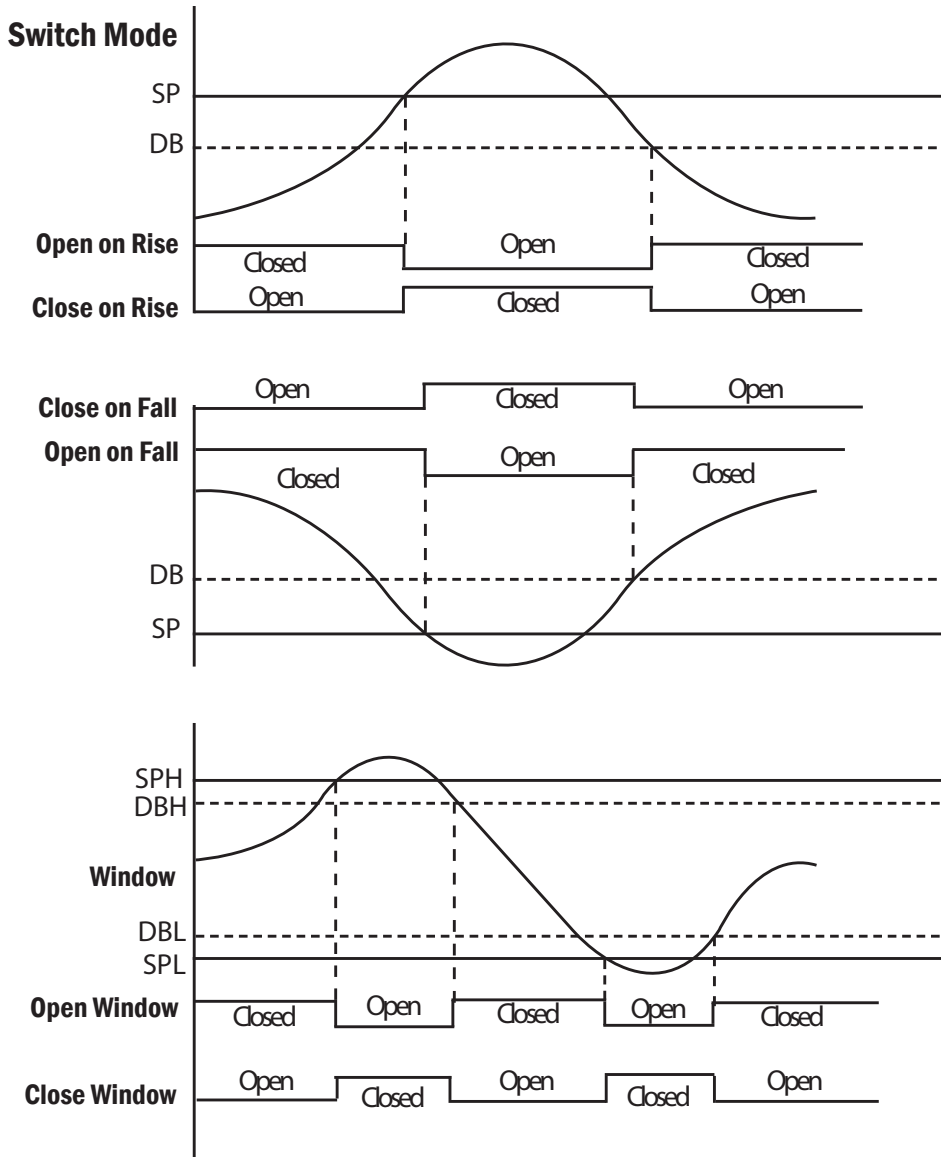

Figure 13

### Resetting the Maximum & Minimum Values

The One Series continuously captures the readings from the sensor and stores one minimum and maximum value since the last time they were reset. The values can be viewed at any time by removing the enclosure cover and pushing the left ↓ button. The display will scroll the values and then return to the Process Display mode.

To reset the values, enter the Programming Mode (see page 10). Repeatedly press the left ↓ button to get to the CLR MAX/MIN command and then press the right → button two times. After exiting the Programming Mode and saving the changes (see page 10), the values will be reset to the current reading and begin recording again.

## ADVANCED FEATURES

**NOTE:** No initial configuration of these features is required. The default for these advanced commands is zero or off.

### Adjusting Display Offset

The One Series is factory calibrated to 0.25% of the sensor's maximum range at room temperature. In some installations, it may be necessary to adjust the display's offset due to the range and position of the sensor. Chemical seals with long capillaries combined with low maximum range sensors are a common cause of offset error. The OFFSET command allows the user to enter a positive ("POS") or negative ("NEG") offset to the display readings. An offset adjustment of up to  $\pm 10\%$  of the sensor's maximum range is allowed.

Example: When the sensor has a zero pressure applied, but the display reads a value other than zero, entering the additive inverse (reversing the sign) of the displayed value for OFFSET will force the display to read zero.

**NOTE:** Any numerical value entered other than 0.00 will cause the display to indicate "Offset" just above the process reading in the process display.



USE OF THIS OPTION MAY CREATE A CONDITION WHERE THE DISPLAY MAY INDICATE "0.00" WHEN SIGNIFICANT PRESSURE OR TEMPERATURE (UP TO 10% OF MAXIMUM RANGE) EXISTS IN THE SYSTEM. INDEPENDENT VERIFICATION OF THE PROCESS VARIABLE SHOULD BE DONE PRIOR TO MAINTENANCE ON THE SYSTEM WHEN "OFFSET" APPEARS ON THE DISPLAY.

Refer to the Programming Flowchart on page 21.

- Enter the Programming Mode and use the left  $\downarrow$  button to move to the OFST command.
- Press the right  $\rightarrow$  button to select a positive or negative offset. POS is default. Use the left  $\downarrow$  button to change to NEG.
- Press the right  $\rightarrow$  button to view and change the offset. Zero is the factory setting. Press the left  $\downarrow$  button to increment the blinking digit. Press the right  $\rightarrow$  button to enter and move to the next digit.
- Press the right  $\rightarrow$  button to enter the new offset and return to the main menu.

### Adjusting Span

SPAN provides an adjustment to shift the slope of the sensor's response curve to accommodate an offset value other than zero. To adjust SPAN, calculate and enter a new SPAN value.

To calculate the SPAN value, apply a reference source below maximum scale to the sensor. Record the value that shows on the One Series display and the reference source value. Divide the reference source value by the display value and then multiply the result by the sensor's upper range.

FORMULA:  $\text{SPAN} = \text{reference source} / \text{display value} \times \text{upper range value}$

- Pressure example: For a sensor range of 0 - 100 psi, choose a reference source (90) below the upper range limit (100) to prevent an over range condition. Divide the reference source value from the resulting display value (88). Multiply the result by the upper range limit.  $\text{Span} = 90 / 88 \times 100 = 102$  (rounded)
- Temperature example: For a sensor range of -40 to 450°F, choose a reference source (400) below the upper range limit (450) to prevent an over range condition. Divide the reference source value from the resulting display value (404). Multiply the result by the upper range limit.  $\text{Span} = 400 / 404 \times 450 = 446$  (rounded)

Refer to the Programming Flowchart on page 21.

- Enter the Programming Mode (see page 10) and use the left  $\downarrow$  button to move to the SPAN command.
- Press the right  $\rightarrow$  button to select a positive or negative span. POS is the default. Use the left  $\downarrow$  button to change to NEG.
- Press the right  $\rightarrow$  button to view and change the span. Zero is the factory setting. Press the left  $\downarrow$  button to increment the blinking digit. Press the right  $\rightarrow$  button to enter and move to the next digit.

**NOTE:** To return to factory calibration settings, enter all zeros for both SPAN and OFST.

### Setting the Latch Mode (Manual Reset) (Model 1XTXSW Only)

SW1 and SW2 can be configured to latch when the set point is reached. Refer to the Programming Flowchart on page 21.

- LCH1: In the Programming Mode, press the right → button. Repeat these steps for LCH2
- If OFF is displayed, press the left ↓ button to set LCH1 to ON.
- Press the right → button to set the latch. When latch mode is on (set), the Switch changes state when the set point is crossed and remains latched until the Switch is manually reset by the user or the One Series is power cycled.

When latched, the display will read MAN RSET.

To Reset the Latch

- Enter the Programming Mode (see page 10). If the Latch is set, the display will read MAN RSET. To return to the Process Display without resetting the latch, press the right → button.
- To continue programming without resetting the latch, press the left ↓ button.
- Press both ↓→ buttons to reset the latch. The display now reads RSET DONE.
- Press the right → button to return to the Process Display.
- Press the left ↓ button to continue Programming.

### Setting the Plugged Port Feature

The One Series IAW® self-diagnostics have the ability to detect that the process port may be plugged. It does this by monitoring the sensor for changes over time. The amount of change and the time period are configurable. If the process variable does not change by the amount and selected time period, the display will indicate PLUG and the IAW® Output will open, indicating a fault. Refer to the Programming Flowchart on page 21.

- Enter the Programming Mode and press the left ↓ button until PLUG PORT is scrolling on display. Press the right → button.
- There are four possible selections -
  - OFF - This disables the plugged port function and is the default setting. This should be done where sensor plugging is not a concern or where the system pressures may not change over time (example: a storage tank).
  - 1 minute
  - 1 Hour
  - 24 Hours

} Maximum time with no process variation before fault indication
- Using the left ↓ button, select a time.
- If OFF is selected, press the right → button to return to the PLUG PORT command and leave Plug Port deactivated.
- Press the right → button to enter a process value  $\leq$  10% of the sensor's maximum range. This number represents the minimum variation expected in the process value over the time period entered above under normal operating conditions. Each time the process value reaches this value, the Plug Port timer is reset.

**NOTE:** This value can be accurately determined by subtracting the minimum from the maximum process value as recorded by the MAX/MIN feature. See RESETTING MAXIMUM AND MINIMUM VALUES on page 12 for additional information.

## Resetting Trip Count (Model 1TXSW Only)

Trip Count provides information that may be useful for troubleshooting a process. Each time the set point is reached, the trip count is incremented by 1, up to 9999, where it will automatically return to 1. Trip Count is always on and can be manually reset to zero at any time by following these steps.

Refer to the Programming Flowchart on page 21.

- Enter the Programming Mode (see page 10)
- Press and release the left ↓ button until RESET TRIP CNT1 appears on the display. Repeat these steps for RESET TRIP CNT2.
- Press the right → button. The recorded value of times the set point was reached (the trip count) will appear on the display.
  - Press the right → button to clear (reset) the trip count to zero.
  - Press the left ↓ button to retain the trip count value without resetting.

## Setting the Filter

In some applications, it is desirable to “dampen” the switch response and prevent intermittent false trips due to pressure spikes or other transient/isolated events. The Filter feature provides a software digital filter with a configuration time constant for suppressing certain transient short-duration events.

Refer to the Programming Flowchart on page xx

- Enter the Programming Mode (see page xx) and move through the commands until FILTER is scrolling on the display. Press the right → button.
- The available selections are as follows

Pressure Models:	OFF (Default)	Temperature Models:	1/2 second
	1/4 second		1 second
	1/2 second		2 seconds
	1 second		
	2 seconds		

- Using the left ↓ button, select a time constant.
- Press the right → button to enter the time constant and return to main menu.

**NOTE:** The One Series typically responds to a process value change in less than 100 milliseconds when the Filter is set to off. Using this feature can lengthen the overall response time of the One Series for certain types of process value changes (pressure spikes).

- A shorter delay setting provides a faster response but is less stable.
- A longer delay setting provides a slower response and is more stable.

## Setting the Trip Delay (Model 1TXSW Only)

The Trip Delay provides a configurable delay for SW1 and SW2 with a range of 0 – 999.9 seconds. Zero seconds is the factory default. When the set point is reached, the switch trip will be delayed by the number of seconds entered into the Trip Delay command using the following steps.

Refer to the Programming Flowchart on page 21.

- Enter the Programming Mode (see page 10)
- Press and release the left ↓ button until TRIP DELAY1 scrolls on the display. Repeat these steps for TRIP DELAY2.
- Press the right → button. OFF will appear on the display.
- Press the left ↓ button to select ON. The Trip Delay value in seconds (default = 000.0) will appear on the display with the left digit blinking.
  - Press the left ↓ button to increment the blinking digit.
  - Press the right → button to move to the next digit.
- Press the right → button to enter the new Trip Delay value.

## SETTING THE SCALE

The 4-20 mA output is field scalable. The default setting is 100% of the sensor's maximum range, where 4 mA represents minimum and 20 mA is maximum range. If desired, both the 4 mA and 20 mA levels may be set independently to shrink or stretch the portion of the sensor's range represented by the 4-20 mA output.

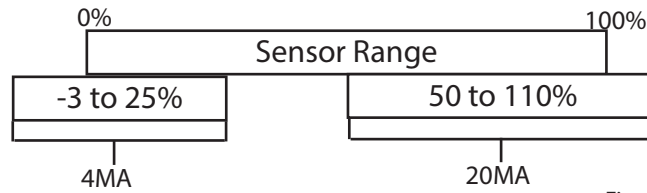

Figure 14

- Setting the 4 mA portion of the scale (see Figure 14):
  - Enter the Programming Mode (see page 10) and use the left ↓ button to move to the 4MA SET command.
  - Press the right → button to select a positive or negative scale. POS is the default. Use the left ↓ button to change to NEG.
  - Press the right → button to view and change the scale. Press the left ↓ button to increment the blinking digit. Press the right → button to enter and move to the next digit. This process value must be between -3% and 25% of the sensor's maximum range.
  - Press the right → button to enter the new scale and return to the main menu.
- Setting the 20 mA portion of the scale (see Figure 14):
  - Enter the Programming Mode (see page 10) and use the left ↓ button to move the 20MA SET command.
  - Press the right → button to select a positive or negative scale. POS is the default. Use the left ↓ button to change to NEG.
  - Press the right → button to view and change the scale. Press the left ↓ button to increment the blinking digit. Press the right → button to enter and move to the next digit. This process value must be between 50% and 110% of the sensor's maximum range.
  - Press the right → button to enter the new scale and return to the main menu.

**NOTE:** Scaling the 4-20 mA output over a smaller portion of the sensor's range does not increase the accuracy of the proportional output. A 2:1 turndown is possible using these commands.

## DISPLAY MODULE CALIBRATION

These serial numbers must match for proper operation.

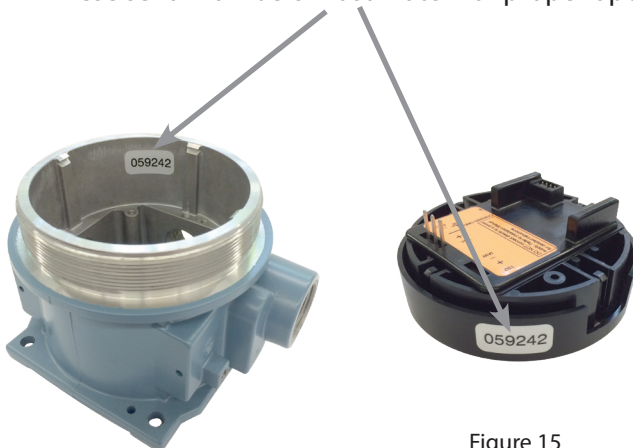

**NOTE:** Do not replace the One Series display module or pressure sensor. Swapping these amongst devices will cause a mis-match between the stored sensor calibration data and the pressure sensor. For proper operation, the display module serial number must always match the serial number inside the enclosure (see Figure 15).

Figure 15



## HART® Commands:

All of the configurable features of the One Series that were detailed in the previous pages can be performed using a HART® version 7 compatible communicator such as those manufactured by Yokogawa, Meriam and Emerson. The One Series 1XTXSW and 1TX00 provide the latest available HART® version 7 and include a Device Description (DD) that enables device specific commands for access to and setting the transmitter relay (model 1XTXSW only) parameters.

Below (see Table 5) is the list of the HART® commands implemented. Details of Universal and Common Practice Commands may be found in the Universal Command Specification (HCF\_SPEC-127) and Common Practice Command Specification (HCF\_SPEC-151) published by the HART Communications Foundation, now part of the FieldComm Group. <http://en.hartcomm.org/>

Details of the One Series device specific commands and the device description file may be found on United Electric Controls website:

<https://www.ueonline.com/products/hazardous-location/one-series/> under HART® Protocol Resources.

Command	Description	Type
0	Read Device ID	Universal
1	Read Primary Variable	Universal
2	Read Loop Current and Percentage of Range	Universal
3	Read Dynamic Variables and Loop Current	Universal
6	Write Polling Address	Universal
7	Read Loop Configuration	Universal
8	Read Dynamic Variable Classifications	Universal
9	Read Device Variables with Status	Universal
11	Read Unique Identifier Associated with Tag	Universal
12	Read Message	Universal
13	Read Tag, Descriptor, Date	Universal
14	Read Primary Variable Transducer Information	Universal
15	Read Device Information	Universal
16	Read Final Assembly Number	Universal
17	Write Message	Universal
18	Write Tag, Descriptor, Date	Universal
19	Write Final Assembly Number	Universal
20	Read Long Tag	Universal
21	Read Unique Identifier Associated with Long Tag	Universal
22	Write Long Tag	Universal
38	Reset Configuration Changed Flag	Universal
48	Read Additional Device Status	Universal
33	Read Device Variables	Common Practice
34	Write Primary Variable Damping Value	Common Practice
35	Write Primary Variable Range Values <i>Data written using command 35 will update the 4mA and 20mA settings in the menu.</i>	Common Practice
36	Set Primary Variable Upper Range Value	Common Practice
37	Set Primary Variable Lower Range Value	Common Practice
40	Enter/Exit Fixed Current Mode	Common Practice
41	Perform Self Test	Common Practice
44	Write Primary Variable Units	Common Practice
45	Trim Loop Current Zero	Common Practice
46	Trim Loop Current Gain	Common Practice
47	Write Primary Variable Transfer Function	Common Practice
54	Read Device Variable Information	Common Practice

## HART Commands Cont.

Command	Description	Type
59	Write Number of Response Preambles	Common Practice
71	Lock Device	Common Practice
76	Read Lock Device State	Common Practice
140	Write Field Stats Information <i>Overwrites the Max and Min values from the device.</i>	Device Specific
141	Read Field Stats Information <i>Reads the current Max and Min values from the device.</i>	Device Specific
221	Write Protect Enable/Disable, Modify Password <i>Allows write protect mode to be enabled/disabled and allows editing of the device password.</i>	Device Specific
222	Read, Write Protect Status <i>Reads the write protect status of the device.</i>	Device Specific
223	Write Trip Counters <i>Writes an unsigned 16-bit integer between 0 – 9999 to the trip counters associated with switch 1 and switch 2 (Trips 1 and 2).</i>	Device Specific
224	Trips 1 and 2 <i>Reads the value of the trip counters associated with switch 1 and switch 2 (Trips 1 and 2). The number is an unsigned 16-bit integer between 0 – 9999.</i>	Device Specific
225	Manual Reset <i>Resets one or more switches that are in the latched state.</i>	Device Specific
226	Read Switch Latch Status <i>Reads the latch status of one or more switches.</i>	Device Specific
244	Write Switch Configuration <i>Write Switch Number, Mode, Set Points, Deadbands, Latch Settings, Trip Delay Settings</i>	Device Specific
245	Read Switch Configuration <i>Read Switch Number, Mode, Set Points, Deadbands, Latch Settings, Trip Delay Settings</i>	Device Specific
246	Write Plugged Port Settings <i>Enable/Disable Plugged Port Feature, set plugged port time and threshold.</i>	Device Specific
247	Read Plugged Port Settings <i>Read Plugged Port time and threshold.</i>	Device Specific
248	Write Offset and Span <i>Writes offset and span values for the purpose of calibration to the offset and span menu entries.</i>	Device Specific
249	Read Offset and Span <i>Reads offset and span values from the device.</i>	Device Specific

Table 5

## ONE SERIES FAULT CODES

The One Series IAW® diagnostics are capable of detecting many possible fault conditions. Some fault conditions will clear automatically when the parameter returns to normal; others require the device to be powered down and restarted; and some may require repair or replacement. A list of fault conditions are shown below in table 6.

If a fault message appears on the One Series display, a fault code can be obtained by pressing both keypad buttons ↓→ simultaneously.

Please provide this code if calling UE Inside Sales for assistance.

Code		Probable Cause	Reason	Action
E-	04	Loop Current Fault	The current measured in the 4-20mA loop, by the fault monitoring circuitry, is incorrect.	Verify that the power supply voltage and load resistance on the 4-20mA loop are within allowable limits.
E-	15	Diagnostic Fault Sensor OPEN	An open circuit has been detected on the sensor drive pins 2 & 3.	Diagnostic Fault Sensor open, check all sensor connections.
E-	16	Diagnostic Fault Sensor SHORT	A short circuit has been detected on the sensor drive pins 2 & 3.	Diagnostic Fault Sensor Short, check all sensor connections.
E-	18	Diagnostic Fault Relay Monitor	The relay output fault monitor circuit has detected that the output state of the solid state relay is incorrect. This feature must be enabled in the menu.	Check the wiring connections or disable feature if not being used.
E-	65	Error -- switch output	The switch output fault monitor circuit has detected that the switch output state is incorrect.	Internal Hardware Fault, contact factory
E-	88	Error -- Process Variable Extreme Overrange	Extreme overrange, a pressure input has exceeded 150% of the operating range or a temperature input has exceeded 110% of range.	Warning: This fault may indicate damage to the sensor. Check that the process is within the operating limits of the device. Verify all sensor connections.

Table 6

NOTE: Power cycling the One Series will reset some faults. If the fault remains after power cycling, please contact UE Inside Sales at [Insidesales@ueonline.com](mailto:Insidesales@ueonline.com) or call +1 (617)-923-6977. Some fault codes not noted above indicate microprocessor faults.

## DISCRETE OUTPUTS TRUTH TABLE\*

Set Point Reached?	IAW™ Fault?	SW1 & SW2 (as configured)	IAW™ Output
No	No	Normal State	Closed
No	Yes	Tripped State	Fail Safe Open
Yes	No	Tripped State	Closed
Yes	Yes	Tripped State	Fail Safe Open

Table 7

## TROUBLESHOOTING\*

The relays and switches contained in the One Series are electronic. The on/off switch signal is produced by a transistor or a solid-state relay, depending on the One Series model. Electronic switches cannot be properly tested with an ohmmeter. Instead, measure the voltage drop across the switch connected to the intended load to determine if it is open or closed. A properly functioning One Series electronic switch will exhibit the following voltage levels (see Table 8).

Electronic Switch Voltage Levels			
Signal Name	Location	Voltage Open (powersupply dependent)	Voltage Closed
SW1	TB2 (no polarity)	0 – 280 VAC or VDC	0 Volts (Nominal)
SW2	TB2 (no polarity)	0 – 280 VAC or VDC	0 Volts (Nominal)
IAW® OUTPUT	TB3-2 (+) & TB3-1 (-)	0 – 30 VDC	0 VDC (Nominal)

Table 8

\*Model 1XTXSW Only

## LOST PASSWORDS

Contact UE Inside Sales at +1-617-923-6977 or go online at [www.UEonline.com/UUC](http://www.UEonline.com/UUC) to obtain a unique unlock code. The Kanban number from the product nameplate is required (see Figure 16).

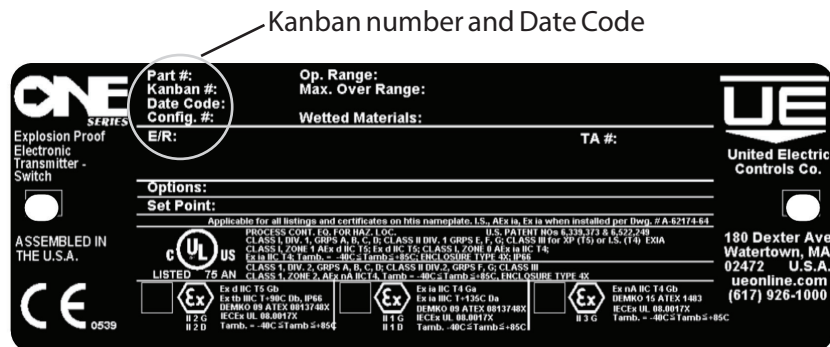
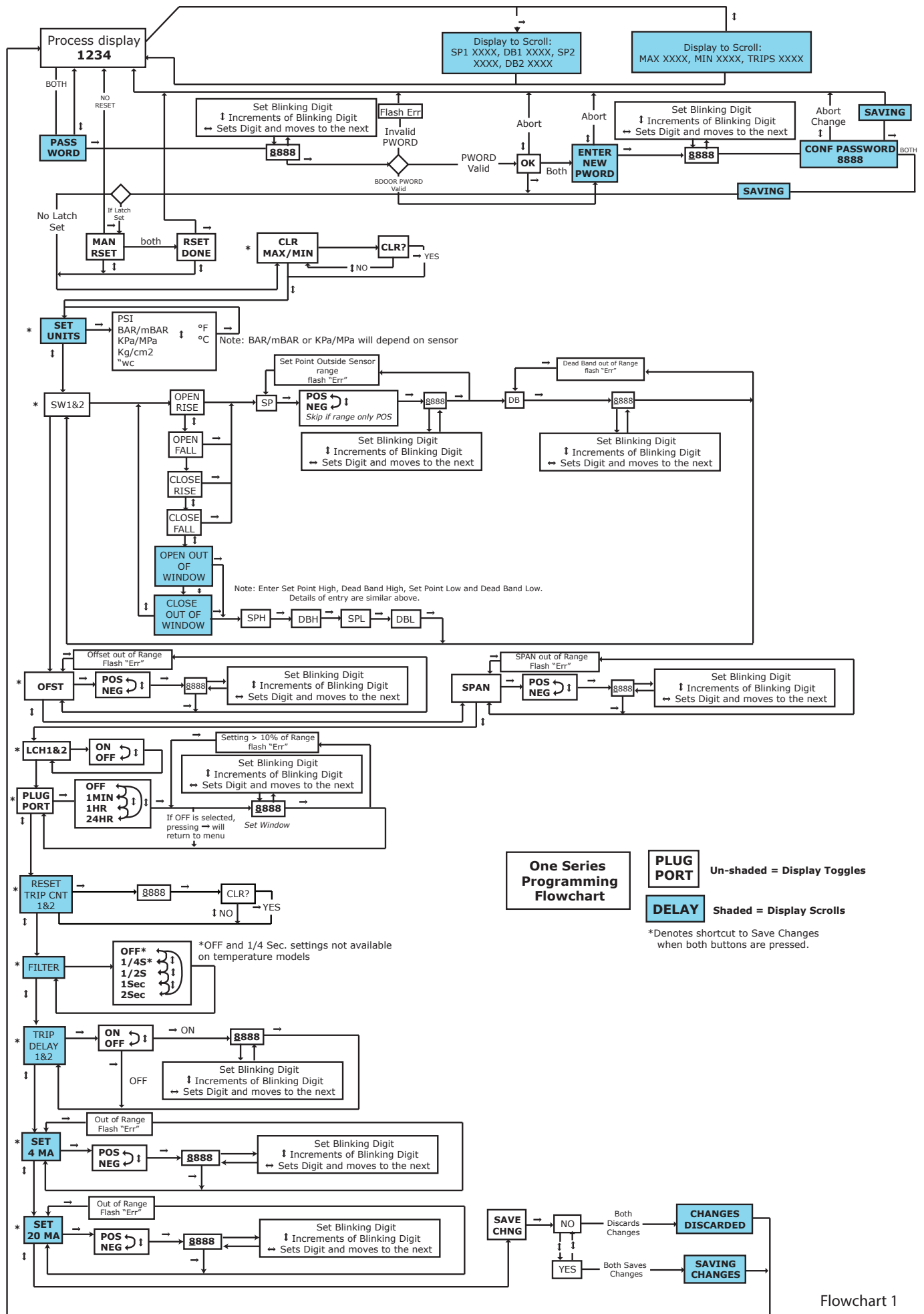
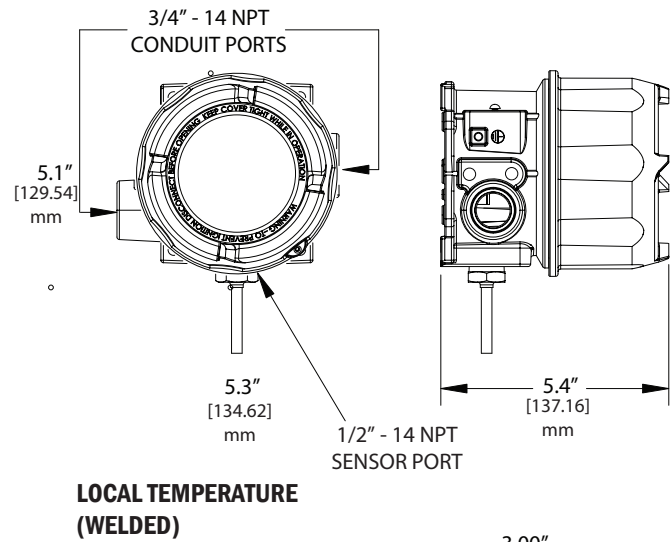
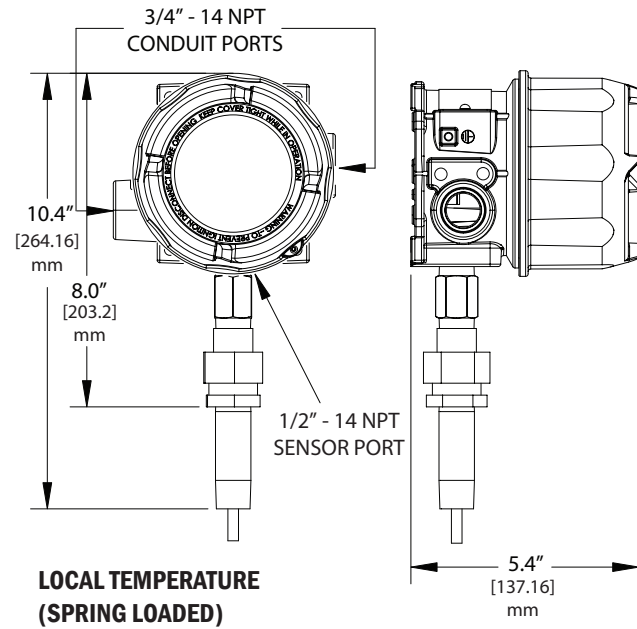
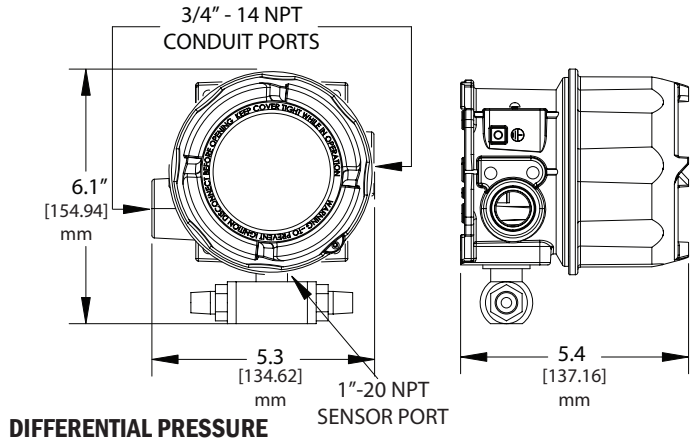
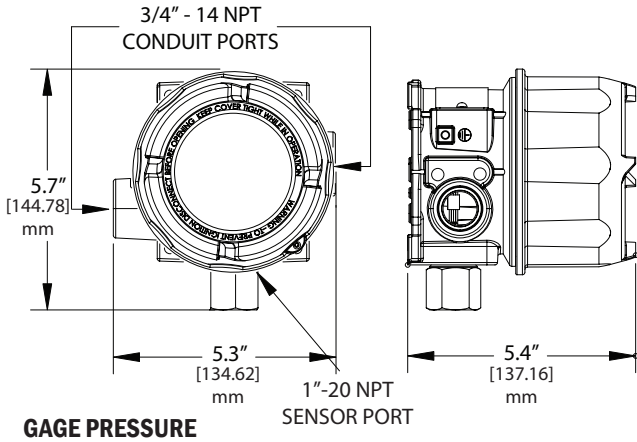

Figure 16



Flowchart 1

# DIMENSIONAL DRAWINGS



**CLEARANCE HOLE FOR 1/4" BOLT 4 PLCS**

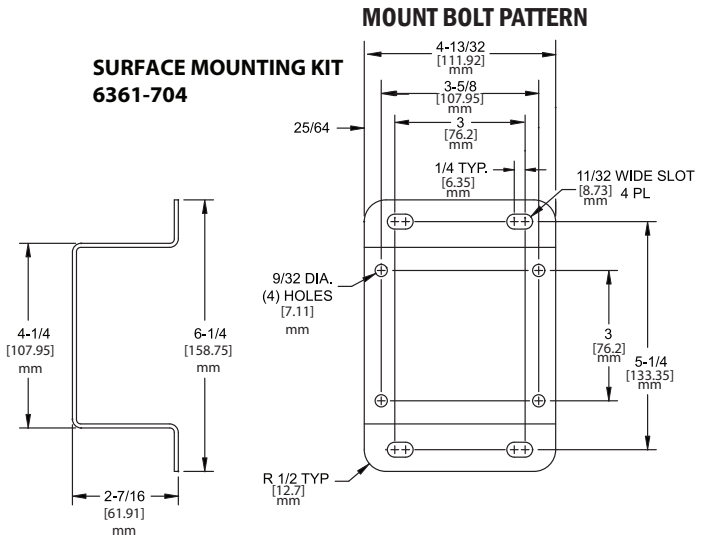
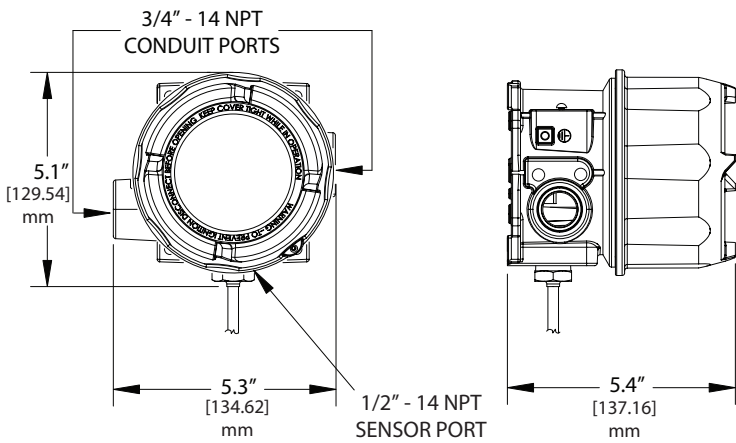
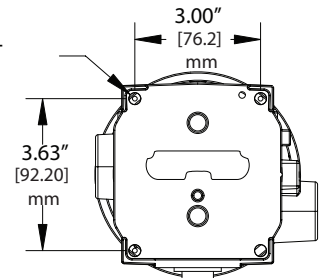



# SENSOR OPTIONS

## Pressure Sensors

### Gauge Pressure

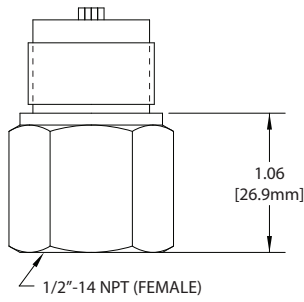

### Differential Pressure

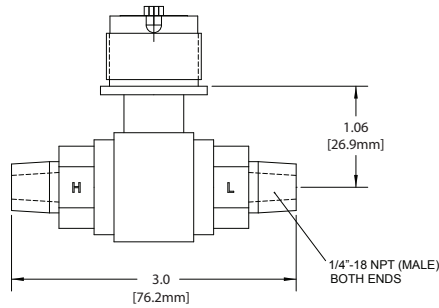

### Dual Seal with Gage Pressure Sensor (Option M041)

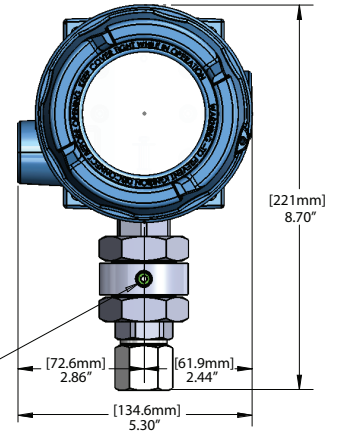

## Temperature Sensors

### Fixed Local (TL1 - TL3)

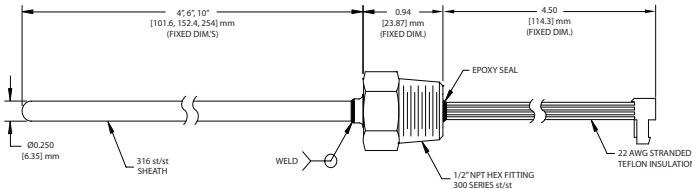

### Spring Loaded Local (TTC)

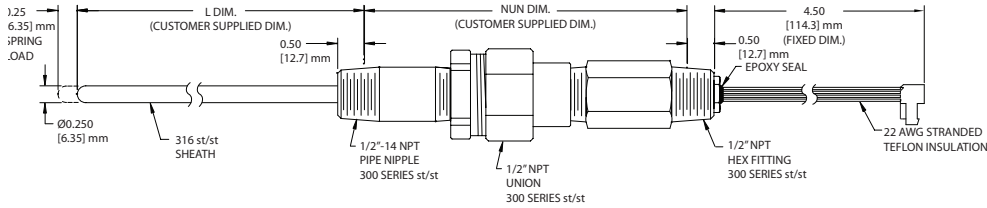

### Remote (TR1, TRC, TH1, THC, TC1, TCC)

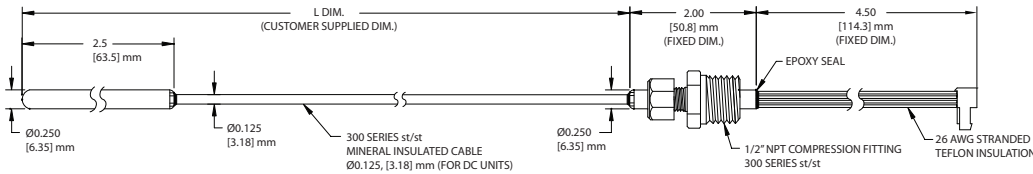

### Thermowell Adapter Kit Option W081 (UE Part #62169-44)

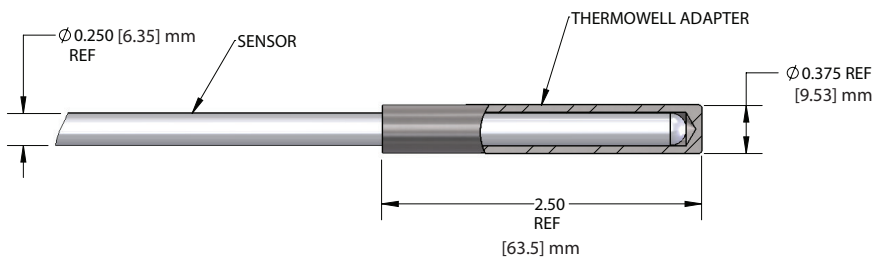

## FRENCH WARNING TRANSLATIONS

Page	Warning Text	Texte d'avertissement
1	Misuse of this product may cause explosion and personal injury. These instructions must be thoroughly read and understood before unit is installed. See the product nameplate information for specific agency certifications applicable to your product.	Utilisation abusive de ce produit peut causer une explosion et des blessures. Ces instructions doivent être soigneusement lues et comprises avant l'appareil est installé. Voir l'information sur la plaque signalétique du produit pour les certifications d'agence spécifiques applicables.
1	Substitution of components may impair suitability for use in hazardous locations. Cable glands used must be rated for a minimum of IP66 in order to maintain the same IP rating.	La substitution de composants peut nuire à l'aptitude à l'utilisation dans des endroits dangereux. Les presse-étoupes utilisés doivent avoir un indice de protection IP66 minimum afin de conserver le même indice de protection IP.
1	For zone hazardous locations, all cable entry devices shall be certified in type of explosion protection flameproof enclosure "d" with an IP66 rating suitable for the conditions of use and correctly installed. If cables and cable glands are not used, a stopping box shall be provided within 2" of the enclosure. Flameproof joint and gap details are provided on page 2.	Pour les zones explosives poussiéreuses, tous les dispositifs d'entrée de câble doivent être certifiés dans le type de protection de l'enceinte ignifuge "d" avec un indice de protection IP66, adapté aux conditions d'utilisation et correctement installés. Si les câbles et presse-étoupes ne sont pas utilisés, une boîte d'arrêt doit être fournie dans les 5 cm de l'enceinte. Plus de détails sont fournis à la page (2).
1	Install units where shock, vibration and temperature fluctuations are minimal. Orient unit to prevent moisture from entering enclosure. Use properly rated sealing fittings for electrical wire entry. Do not mount unit in ambient temperatures exceeding published limits. This is especially critical for local mount temperature units. Use of a shroud is recommended where direct sunlight and rain may come in contact with the enclosure.	Installez les unités où le choc, vibration et les fluctuations de température sont minimales. Orienter l'unité d'une manière à empêcher l'humidité de pénétrer dans l'enceinte. Utiliser des raccords d'étanchéité bien notés pour l'entrée de fil électrique. Ne pas monter l'unité à des températures ambiantes dépassant les limites publiées. Cela est particulièrement important pour les unités de température à montage local. L'utilisation envelopper est recommandée lorsque le soleil et la pluie peuvent entrer en contact avec le boîtier.
2	Continuous operation should not exceed the designated over range pressure or working pressure range stated within the literature and on device nameplate.	Le fonctionnement continu ne doit pas dépasser la pression de dépassement ou la plage de pression de fonctionnement indiquée dans la documentation et sur la plaque signalétique de l'appareil.
3	Before installing, check the sensor model selected for compatibility to the process media in contact with the sensor and wetted parts.	Avant l'installation, vérifier le modèle de l'appareil sélectionné pour la compatibilité avec le fluide du procédé en contact avec le capteur et les parties mouillées.
3	In all applications, secure the enclosure as detailed below. <u>Do not mount via the process connection only.</u>	Dans toutes les applications, sécuriser l'enceinte comme détaillé ci-dessous. Ne pas installer par la connexion de processus seulement.
4	For pressure and local temperature models, always hold a wrench on the sensor housing hex when mounting the device. <u>Do not tighten by turning the enclosure</u> , as this will damage the connection between the sensor and housing.	Pour tous les modèles de température et pression locaux, toujours tenir une clé sur l'hexagone du capteur pendant le montage de l'unité. Ne pas serrer en tournant l'enceinte, cela pourrait endommager la connexion entre le capteur et l'enceinte.
4	For differential pressure models (especially low range units), mount the sensor level to minimize any pressure reading offsets. The offset command may be used to zero the display (see page xx for additional information).	Pour les modèles de pression différentielle (de pressions faibles), montez le niveau du capteur afin de minimiser tout décalage de lecture de pression. La commande décalée peut être utilisée pour mettre l'affichage à zéro (voir la page xx pour plus d'informations).

## FRENCH WARNING TRANSLATIONS CONT.

Page	Warning Text	Texte d'avertissement
4	Never insert any object into the pressure sensor opening. Damage to the sensor will result, affecting accuracy.	Ne jamais insérer un objet dans l'orifice du capteur de pression. Les dommages à la membrane de capteur se traduira, à affecter la précision.
5	To prevent electrostatic discharge, wipe down cover and enclosure of any dust build-up before removing cover.	Pour éviter les décharges électrostatiques, nettoyez le capot et le boîtier de toute accumulation de poussière avant de retirer le capot.
5	Disconnect all supply circuits before wiring device. Wire device in accordance with local and national electrical codes. Maximum recommended wire size and recommended tightening torque for field wiring terminal blocks are shown within table 2 (page 5).	Débrancher tous les circuits d'alimentation avant de brancher l'appareil. Le câblage doit être effectuée selon les codes électriques nationaux et locaux. Tailles de fils recommandées maximales et couples de serrage pour le terrain câblage des borniers sont indiqués dans le tableau 2 (la page xx).
5	To prevent seizure of enclosure cover, do not remove lubricant. Threads should also be free of dirt and other contaminants.	Pour éviter le grippage du couvercle du boîtier, ne pas enlever le lubrifiant. Les fils doivent également être exempts de saleté et d'autres contaminants.
5	To prevent ignition, disconnect power before removing enclosure cover. Keep cover tight while in operation. Do not disconnect equipment unless power has been switched off or the area is known to non-hazardous.	Pour éviter l'inflammation, couper l'alimentation avant de retirer le couvercle du boîtier. Maintenir le couvercle fermé pendant le fonc coupée ou que la zone est connue pour être non explosives.
5	Do not replace components unless power has been switched off or the area is known to be non-hazardous.	Ne remplacez pas les composants avant que le courant soit coupé ou que la zone est connue pour être non explosives.
5	The devices shall be properly grounded in the end use application using the ground screws provided with the enclosure.	Les appareils doivent être correctement mis à la terre en utilisant les vis de terre fournies avec l'enceinte.
5	Field wiring must be rated 105°C minimum. For ambient temperatures below -10°C, use suitable field wiring.	Câblage sur le terrain doit être évalué à 105°C minimum. Pour une température ambiante inférieure à -10°C, utiliser le câblage approprié.
13	Use of this option may create a condition where the display may indicate "0.00" when significant pressure or temperature (up to 10% of maximum range) exists in the system. Independent verification of the process variable should be done prior to maintenance on the system when "offset" appears on the display.	L'utilisation de cette option peut créer une condition dans laquelle l'écran peut indiquer «0,00» lorsqu'une pression ou une température significative (jusqu'à 10% de la plage maximale) existe dans le système. Une vérification indépendante de la variable de processus doit être effectuée avant la maintenance du système lorsque «offset» apparaît à l'écran.

## RECOMMENDED PRACTICES AND WARNINGS

United Electric Controls Company recommends careful consideration of the following factors when specifying and installing UE pressure and temperature units. Before installing a unit, the Installation and Maintenance instructions provided with unit must be read and understood.

- To avoid damaging unit, proof pressure and maximum temperature limits stated in literature and on nameplates must never be exceeded, even by surges in the system. Operation of the unit up to maximum pressure or temperature is acceptable on a limited basis (e.g., start-up, testing) but continuous operation must be restricted to the designated adjustable range. Excessive cycling at maximum pressure or temperature limits could reduce sensor life.
- A back-up unit is necessary for applications where damage to a primary unit could endanger life, limb or property. A high or low limit switch is necessary for applications where a dangerous runaway condition could result.
- The adjustable range must be selected so that incorrect, inadvertent or malicious setting at any range point cannot result in an unsafe system condition.
- Install unit where shock, vibration and ambient temperature fluctuations will not damage unit or affect operation. When applicable, orient unit so that moisture does not enter the enclosure via the electrical connection. When appropriate, this entry point should be sealed to prevent moisture entry.
- Unit must not be altered or modified after shipment. Consult UE if modification is necessary.
- Monitor operation to observe warning signs of possible damage to unit, such as drift in set point or faulty display. Check unit immediately.
- Preventative maintenance and periodic testing is necessary for critical applications where damage could endanger property or personnel.
- Electrical ratings stated in literature and on nameplate must not be exceeded. Overload on a switch can cause damage, even on the first cycle. Wire unit according to local and national electrical codes, using wire size recommended in installation sheet.
- Do not mount unit in ambient temp. exceeding published limits.

## LIMITED WARRANTY

Seller warrants that the product hereby purchased is, upon delivery, free from defects in material and workmanship and that any such product which is found to be defective in such workmanship or material will be repaired or replaced by Seller (Ex-works, Factory, Watertown, Massachusetts. INCOTERMS); provided, however, that this warranty applies only to equipment found to be so defective within a period of 24 months from the date of manufacture by the Seller (36 months for the Spectra 12 and One Series products; 18 months for Temperature Sensors). Seller shall not be obligated under this warranty for alleged defects which examination discloses are due to tampering, misuse, neglect, improper storage, and in any case where products are disassembled by anyone other than authorized Seller's representatives. EXCEPT FOR THE LIMITED WARRANTY OF REPAIR AND REPLACEMENT STATED ABOVE, SELLER DISCLAIMS ALL WARRANTIES WHATSOEVER WITH RESPECT TO THE PRODUCT, INCLUDING ALL IMPLIED WARRANTIES OF MERCHANTABILITY OR FITNESS FOR ANY PARTICULAR PURPOSE.

## LIMITATION OF SELLER'S LIABILITY

Seller's liability to Buyer for any loss or claim, including liability incurred in connection with (i) breach of any warranty whatsoever, expressed or implied, (ii) a breach of contract, (iii) a negligent act or acts (or negligent failure to act) committed by Seller, or (iv) an act for which strict liability will be inputted to seller, is limited to the "limited warranty" of repair and/or replacement as so stated in our warranty of product. In no event shall the Seller be liable for any special, indirect, consequential or other damages of a like general nature, including, without limitation, loss of profits or production, or loss or expenses of any nature incurred by the buyer or any third party.

UE specifications subject to change without notice.



UNITED ELECTRIC  
CONTROLS

180 Dexter Ave.  
Watertown, MA 02472  
617 926-1000 Fax 617 926-2568  
[www.ueonline.com](http://www.ueonline.com)

ECN #: 6476