

Installation & Maintenance Instructions

MID WEST INSTRUMENT

Model 122



Supplied by

247able.com

Call us on +44 (0)118 916 9420 | Email info@247able.com

Installation and Operating Instructions - Model 122

1. Safety



Before installing verify compatibility to the process media and temperature in contact with the wetted parts. Incompatible media and / or operation at temperature extremes can cause premature degradation of materials which could result in safety risk to personnel.

Verify the selected pressure range (differential pressure and working pressure) and the switch ratings are within specification for your application.

The Model 122 product utilizes a piston design which inherently has a small amount of leakage from high process connection to low process (15 SCFH air max at 100 PSID) connection. Do not use this product in an application with the low side process connection left open to atmosphere.

Warning! Remaining media may result in a risk to personnel, environment etc. Use sufficient precautionary measures when removing and transporting the product.

1.1 Intended use: The indicating / non-indicating differential pressure switches are used for monitoring differential pressures in industrial applications. The manufacturer shall not be liable for any claims if the product is used in applications contrary to the intended use.

1.2 Personnel: Personnel installing and putting this instrumentation into service shall be suitably trained and qualified in accordance with local codes, practices and regulations.



PRODUCT DESCRIPTION

The Model 122 Series “Filter Minder”[®] is a rugged, medium-range differential pressure instrument available as a switch, a gauge, or both. See “Part Numbering System” for available options.

Differential pressure is sensed by the movement of a floating piston magnet against a calibrated spring. The magnetically coupled gauge pointer outside the pressure housing follows the movement of the piston magnet and indicates differential pressure on the dial scale.

When equipped with switches, a contact is made or broken by the magnetic field of the piston magnet. See Bulletin ELECIM122/latest for gauges with switches.

The unit provides full over-range protection to the rated working pressure of the housing in either direction.

INSPECTION

Before installation check the product label on each instrument against the receiving paperwork and the intended application for correct part number, materials of construction, working pressure, dial range, etc. If equipped with switches, check electrical rating, type of enclosure, etc. Inspect for shipping damage and, report it immediately.

NOTE - Before attempting repairs contact your local Mid-West Representative or our factory. Failure to do so will void any warranty.

Installation and Operating Instructions - Model 122

INSTALLATION

Model 122 Series "Filter Minder"® is calibrated and tested prior to shipment and is ready for immediate installation. Use of the following installation procedures should eliminate potential damage and provide optimum trouble-free operation.

1. PROCESS CONNECTIONS

¼" FNPT are provided. There are two connections on the housing identified as "HI" and "LO" for high pressure and low pressure. Be sure these get plumbed to the proper connections on your system. Improper connection will not damage the instrument, but it will not function properly. Flexible tubing is recommended to minimize the effect of possible vibration.

2. INSTRUMENT LOCATION

It is recommended that installation is no closer than one inch of a steel surface otherwise accuracy will be affected. On liquid service the instrument should be mounted **below** the process connections to facilitate self-bleeding. On gas service it should be located **above** the process connections to promote self-draining. If the process contains particulates, a "pigtail" loop or drop leg (manometer "U-tube" configuration) in the tubing will minimize the possibility of it migrating into the instrument.

3. PANEL MOUNTING

This gauge may be mounted into a panel. The cutout dimensions and hole position is described below.

DIAL SIZE	DIAMETER A	DIAMETER C	DIAMETER H
	Inch (mm)	Inch (mm)	Inch (mm)
2-1/2 in.	3.00 (76.2)	3.50 (88.9)	0.19 (4.7)
4-1/2 in.	5.30 (134.6)	5.63 (143.0)	0.19 (4.7)
6 in.	6.50 (165.1)	7.00 (177.8)	0.19 (4.7)

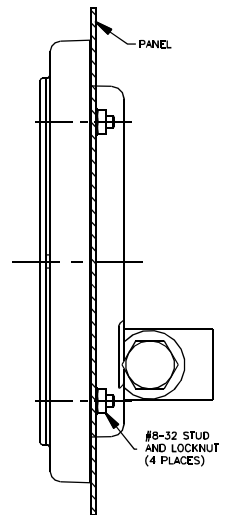
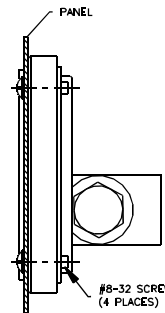
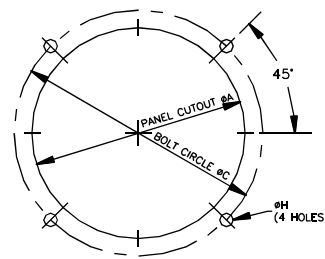

TROUBLE SHOOTING

1. Gauge does not indicate differential

- Check for proper hook up, high to "HI" and low to "LO"
- Make certain block valves are open and, if using a 3-valve manifold, that the equalizer (balance) valve is closed.
- If a & b check out correctly, loosen or disconnect the high pressure line to determine if there is pressure to the instrument.
- If there is pressure to the instrument, check to determine that there is differential across the unit being monitored. If so, contact the factory for assistance and/or an "RGA" (return goods authorization) number to return the instrument for repair or replacement.

Installation & Maintenance Instructions

MID WEST INSTRUMENT

MODEL 122 "Filter Minder"

Supplied by

247cable.com

Call us on +44 (0)118 916 9420 | Email info@247able.com

Mid-West[®] Instrument

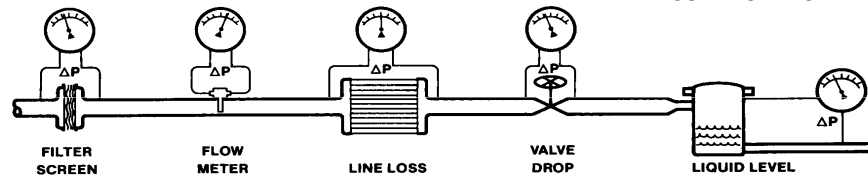

MODEL 122: "Filter Minder"[®] Installation and Operating Instructions

INSPECTION

Before installation check the nameplate on each instrument against the receiving paperwork and the intended application for correct part number, materials of construction, working pressure, dial range, etc. If equipped with switches, check electrical rating. Inspect for shipping damage and, if damaged, report it immediately.

NOTE - Before attempting repairs contact your local Mid-West Representative or our factory. Failure to do so will void any warranty.

PRODUCT DESCRIPTION

The Model 122 "Filter Minder"[®] is a differential pressure instrument available as a switch, a gauge, or both. See "Part Numbering System". (Fig. 2).

Differential pressure is sensed by the movement of a floating piston magnet against a calibrated spring. The magnetically coupled gauge pointer outside the pressure housing follows the movement of the piston magnet and indicates differential pressure on the dial scale.

When equipped with switches, a contact is made or broken by the magnetic field of the piston magnet.

The unit provides full over-range protection to the rated working pressure of the housing in either direction.

Precise piston/bore fit allows minimal leakage from high to low sides. Leakage at ambient conditions will not exceed 15 SCFH air at 100 PSID.

INSTALLATION

The model 122 is calibrated and tested prior to shipment and is ready for immediate installation. Use of the following installation procedures should eliminate potential damage and provide optimum trouble-free operation.

1. PROCESS CONNECTIONS

1/4" FNPT are provided as standard. There are two connections on the housing identified as "hi" and "lo" for high pressure and low pressure. Be sure these get plumbed to the proper connections on your system. Improper connection will not damage the instrument, but it will not function properly. Flexible tubing is recommended to minimize effect of possible vibration.

2. INSTRUMENT LOCATION

On liquid service the instrument should be mounted **below** the process connections to facilitate self-bleeding. On gas service it should be located **above** the process connections to promote self-draining. If the process contains particulates, a "pigtail" loop or drop leg (manometer "U-tube" configuration) in the tubing will minimize the possibility of it migrating into the instrument.

3. PANEL MOUNTING

Gauges with 2-1/2" dials can only be mounted through the **rear** of the panel. Make the proper panel cutout as indicated in (Fig. 1). Remove the (4) bezel screws. Insert the gauge front through the rear of the panel and reinstall the bezel screws through the front of the panel and into the gauge bezel. Tighten the screws securely, alternating in a **diagonal** pattern.

Gauges with a 3-1/2" dial should be mounted from the front of the panel. Contact factory for mounting information and dimensional data.

Gauges with 4-1/2" dial should be mounted from the **front** of the panel. Make the cutout as indicated in (Fig. 1). Insert the (4) panel mounting studs, finger tight, into the metal inserts located in the rear of the bezel. Insert the gauge through the panel, aligning the panel mounting studs with the holes in the panel. Install the (4) #8-32 nuts onto the studs and tighten securely.

4. ELECTRICAL (Switch Units Only)



WARNING: ELECTRICAL CONNECTIONS SHOULD BE PERFORMED BY QUALIFIED PERSONNEL AND MEET REPRESENTATIVE NATIONAL ELECTRICAL CODE.

WARNING: FAILURE TO CONNECT TO THE PROTECTIVE CONDUCTOR TERMINAL MAY RESULT IN A SHOCK HAZARD.

Gauges with switches have one or two Single Pole Single Throw (SPST) or Single Pole Double Throw (SPDT) reed switches with the resistive ratings specified in the following table.

A provision to connect a protective conductor terminal is provided on the Low port end of the gauge body. A 6-32 screw, 18 Awg, green/yellow wire, and a #6 terminal is provided.



CHASSIS

Electrical connections for the SPDT switch are defined as follows:

White- Com
Black- NC
Red - NO

REED SWITCH RATINGS (Resistive Load)



Type	SPST NO	SPST NO	SPDT	SPDT
Option:	B ***	E	H	A
*Power	50 W	60 W	60 W	3W
Max. Current	0.5 Amps	3.0 Amps	1.0 Amps	0.25 Amps
Max. Voltage VAC/VDC	240	240	240	125
**Setting (%F.S.)	10 to 100	25 to 100	25 to 100	10 to 100
Hysteresis (Max/Nom)	10% / 2% (F.S.)	15% / 8% (F.S.)	25% / 13% (F.S.)	10% / 5% (F.S.)
Repeatability	1% F.S.	1% F.S.	1% F.S.	1% F.S.
Leads 22 Awg.	(2), 24"	(2), 24"	(3), 24"	(3), 24"

* Product of the switching voltage and current shall not exceed the power rating of the device.

** Except where otherwise noted

*** B option is available, however is not identified in Electrical Specifications. (Recommend using E)

Note: Switches can be set below the defined minimum set point however, the switch may not remain activated at maximum PSID. If the unit is set below the defined minimum

set point, the customer should verify that the switch remains activated from the set point to over range of the gauge.

Provide standard protection techniques for the switch contacts for capacitive and inductive loads. Use current limiting techniques near the switch to protect the contacts due to high inrush (i.e.; in line resistor or inductor) for long cable interfaces. Provide clamping devices at or near inductive loads (i.e.; relay). **Maximum wire length between the 3W switch and its load, should not exceed 70 – 100 Feet. for 120 VAC applications.** Contact the factory for assistance regarding this condition.

For loads above the switch rating, use Mid-West Power Relay 1000TR. The Model 1000TR is available in various configurations and can control loads rated to 10 Amps

TROUBLESHOOTING

1. Gauge does not indicate differential.

- Check for proper hook up, high to "hi" low to "lo".
- Make certain block valves are open and that the equalizer (balance) valve is closed (if using a 3 valve manifold).
- If A & B check out correctly, loosen high-pressure line to determine if there is pressure to the instrument.
- If there is pressure to the instrument, check to determine that there is differential across the unit being monitored. If so, contact the factory for assistance and/or an "RGA" (Return Goods Authorization) number to return the instrument for repair or replacement.

2. Switch does not function

- Make sure that the switch load does not exceed the specified wattage rating of the switch. (steady-state and transient). Contact factory for assistance for excessive loads, otherwise proceed to the next step.
- Perform a continuity check of the switch contacts by trying to actuate the switch using an external magnet. An operational switch usually indicates a problem with the gauge. If not operational refer to 1.D.

3. Gauge accuracy and set point problems:

- Verify gauge is not in an electromagnetic / magnetic environment. i.e.; close proximity to high current power lines.
- All others refer to 1.D.

MOUNTING INFORMATION & DIMENSIONAL DATA

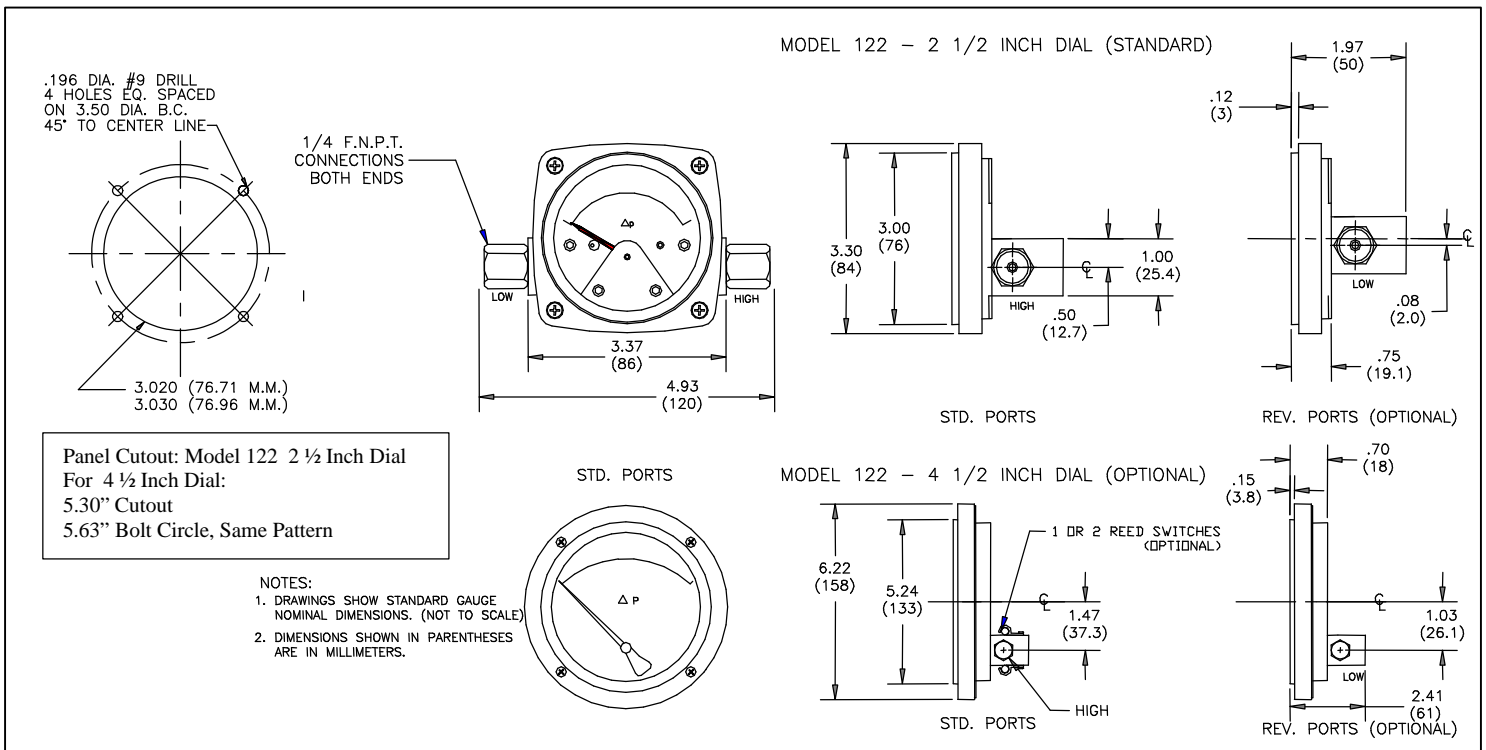

Figure 1

Manufacturer reserves the right to change specifications without prior notice.

PROOF PRESSURE: 10,000 PSI.

TEMPERATURE LIMITS: -40°F (-40°C) to + 200°F (+93° C). These limits are based on the entire instrument being saturated to these temperatures.

System (process) temperatures may exceed these limitations with proper installation. Contact our customer service representative for details.

PART NUMBERING SYSTEM

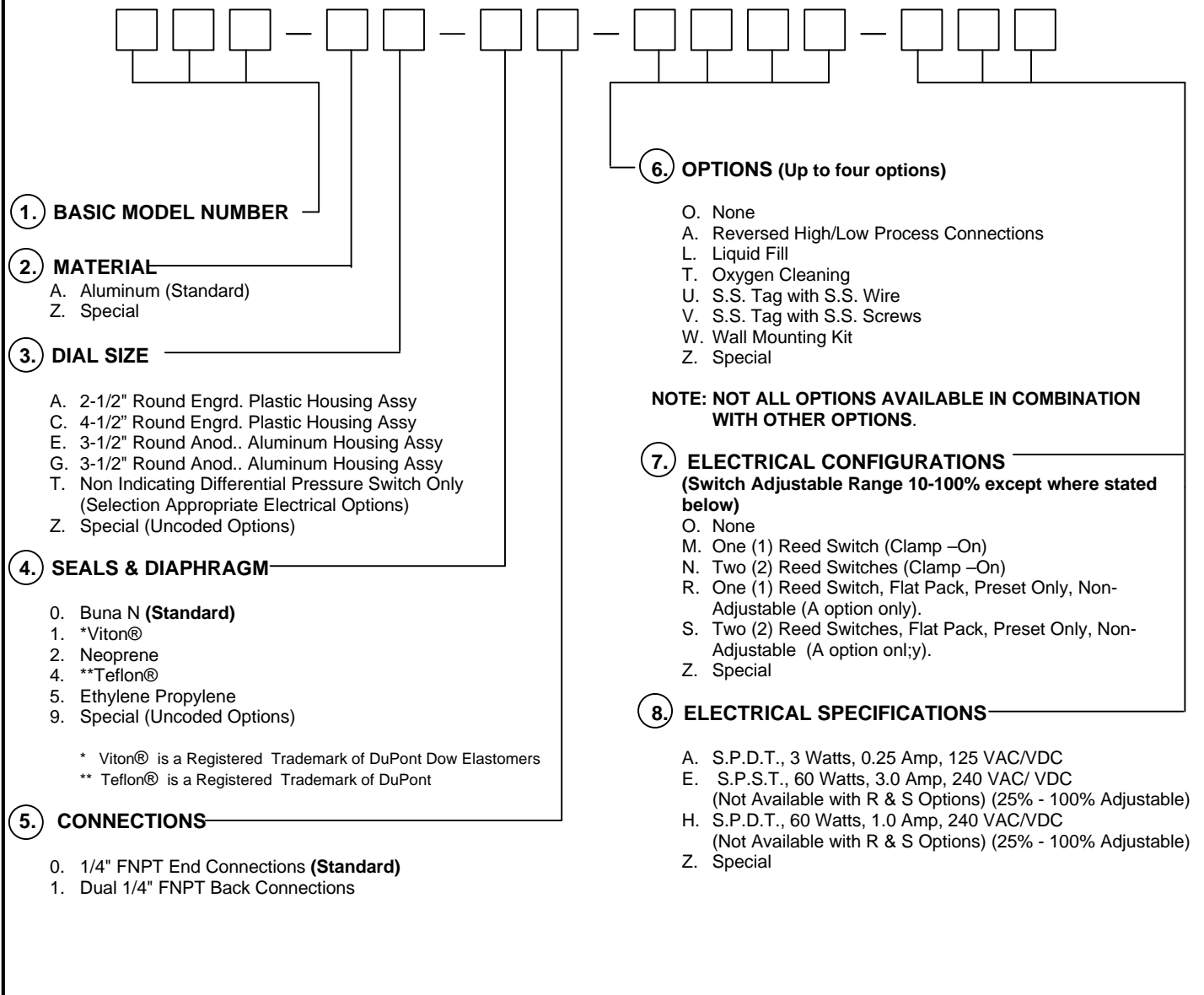

Figure 2

**Mid-West[®]
Instrument**

6500 Dobry Dr. Sterling Heights, MI 48314

(586)254-6500 FAX (586)254-6509

E-Mail: sales@midwestinstrument.com

Web Page: www.midwestinstrument.com