

Installation & Maintenance Instructions

BROOKFIELD

Model Fast-10x In-Line Transmitter Sensor



Supplied by

247able.com

Call us on +44 (0)118 916 9420 | Email info@247able.com

BROOKFIELD MODEL FAST-10X

IN-LINE TRANSMITTER SENSOR

Installation, Operation and Maintenance Instructions

Manual No. M14-5907-A0418

**Critical Document:
No changes allowed
without agency approval.**



INSTRUMENTATION & SPECIALTY CONTROLS DIVISION

11 Commerce Boulevard, Middleboro, MA 02302 USA
Tel: 508-946-6200 or 800-628-8139 (USA excluding MA)
Fax: 508-946-6262 Internet <http://www.brookfieldengineering.com>

Table of Contents

Section 1 - In-Line Viscometer System Description.....	7
Introduction.....	7
Features and Benefits	7
Theory of Operation.....	8
Specifications	10
Component Certification: see Appendix C	10
Component Identification.....	10
Section 2 - Installation	11
Unpacking and Inspection.....	11
Installation Requirements	11
Cleaning	13
Section 3 - Operation	18
Operation.....	18
Section 4 - Maintenance.....	19
Cleaning in Place	19
Section 5 - Service	20
Introduction.....	20
Instrument Repair Procedure and Guidelines	20
Procedure:	21
Appendix A - Customer Support	22
Appendix B - Warranty Information	23
Appendix C - Certification	24

The information in this document is believed to be accurate and reliable. However, AMETEK Brookfield cannot accept any financial or other responsibilities that may result from the use of this information. No warranties are granted or extended by this document.

Brookfield reserves the right to change any or all information contained herein without prior written notice. Revisions may be issued at the time of such changes and/or deletions.

Any duplication of this manual or any of its parts without expressed written permission from Brookfield is strictly prohibited.

Any correspondence regarding this document should be forwarded to:

AMETEK Brookfield
Process Viscometer Division
11 Commerce Boulevard
Middleboro, Massachusetts 02346
U.S.A.
Telephone: (508) 946-6200
FAX: (508) 946-6262
Internet: <http://www.brookfieldengineering.com>

The following Brookfield trademarks and service marks may appear in this document:

All other trademarks or registered trademarks are the property of their respective holders.

Section 1 - In-Line Viscometer

System Description

Introduction

The Brookfield Model FAST-10X In-Line Viscometer is a highly sensitive, versatile instrument that measures process fluid viscosity in a fully flooded product stream under pressure or vacuum.

The FAST-10X In-Line Viscometer is a vibratory style sensor that generates a digital signal that is proportional to viscosity. This digital signal remains stable even under severe process conditions.

The System shown in Figure 1-1 can be used in a variety of industrial applications where the viscosity of chemicals, coatings, inks, and many other process fluids must be monitored.

Features and Benefits

The FAST-10X In-Line Viscometer incorporates the following features:

- Easy startup and operation
- Instantaneous response
- Wide viscosity range
- Multiple output signal options
- Versatile and easy-to-use
- EEPROM with calibration data integrated into sensor

The FAST-10X In-Line Viscometer incorporates the following benefits:

- No rotating parts, therefore, the only seals are static o-ring seals.
- Sensor is cleaned-in-place as part of the system cleaning procedure, thereby, minimizing downtime.
- Repeatable and stable — optimizes product consistency and quality.
- Provides a permanent record for quality control when used with a data recorder or computer system.
- Operates continuously and quickly responds to changes in viscosity.
- Minimal pressure drop across the sensor housing.
- Linear output signals are compatible with most industrial process control equipment.
- Installs directly in-line or in a by-pass line.

AST Model Number Naming Convention

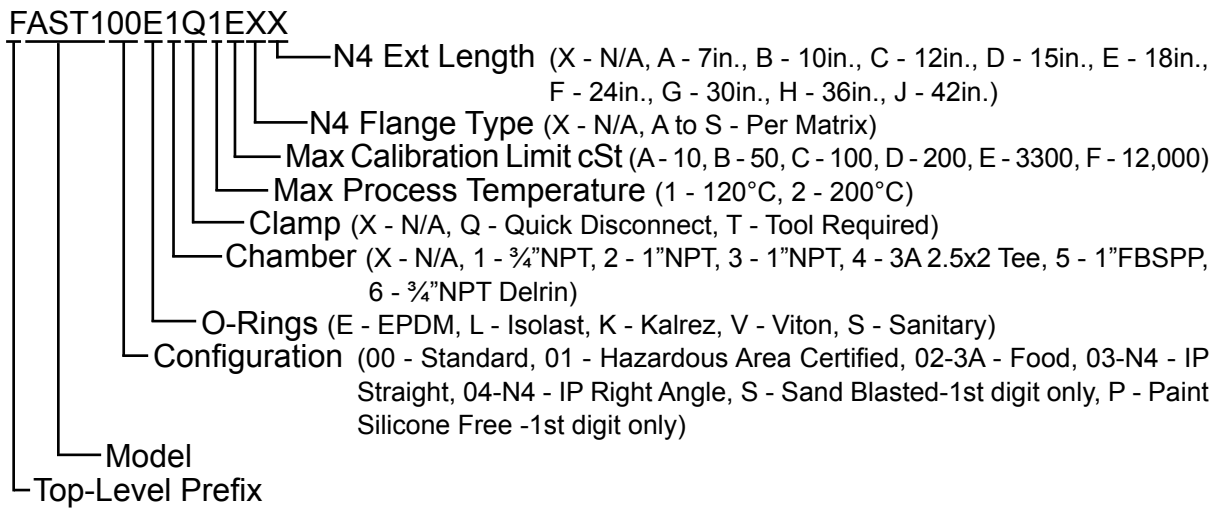

Theory of Operation

The product stream flows through the inlet into the viscosity sensor-measuring chamber, as shown in Figure 1-1, where it is exposed to the sensing probe which is vibrating in a torsional mode. The viscometer has been calibrated and correlates the viscous damping effect of the fluid on the probe to viscosity. The fluid temperature is measured using an RTD (Pt100) located next to the probe. The system (MXT) has 4-20 mA, RS485, RS232 and CAN outputs.

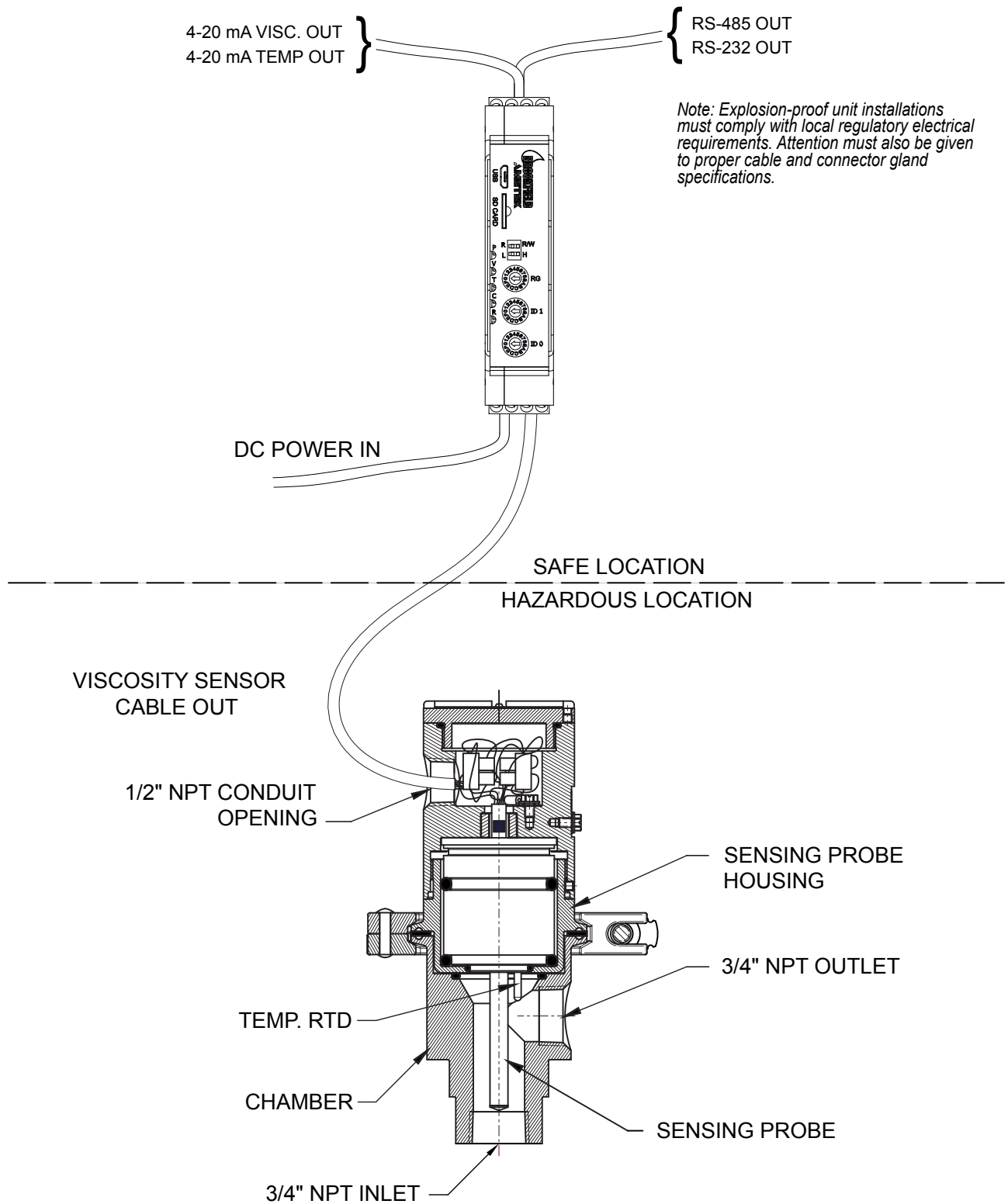

Figure 1-1: Typical FAST-10X System

Specifications

Table 1-1: Model FAST-10X In-Line Viscometer Specifications

Viscometer Specifications	
Viscosity Range	2 to 3,300 cSt Standard 2 to 12,000 cSt Optional
Process Fluid Temp Range	-4°F to 248°F (-20°C to 120°C)
Process Fluid Pressure Range	Vacuum to 200 psig (14 bar)
Sensor Chamber Connections	¾ inch Female NPT 1 inch NPT 1 inch FBSPP
Repeatability/Stability	+/- 1% of Reading
Weight	6.5 lbs (2.9 kg)
Explosion-Proof Classification (Model AST101 only)	See Appendix C

Viscometer Materials of Construction	
Wetted Surfaces	316L Stainless Steel
Probe O-Ring Material	Isolast
Chamber O-Ring Material	EPDM Isolast Kalrez Viton

Component Certification: see Appendix C

Component Identification

The following paragraphs provide a brief description of each component within the Viscometer. Refer to Figure 1-1 for the component location within the system.

Sensing Probe

The Sensing Probe is the 5/16 diameter rod that is immersed in the fluid. This rod senses the viscous damping of the material and that signal is taken back to the electronic enclosure for processing.

Sensing Probe Chamber

This chamber is the component that is plumbed into the process line. Its main function is to house and protect the sensor. The chamber is provided with multiple connection options.

Section 2 - Installation

Unpacking and Inspection

NOTE: Upon receipt, inspect the shipping carton and viscometer components for shipping damage. Report any damage to the shipping company immediately.

NOTE: Throughout this procedure take precautions not to allow the sensing probe to come in contact with any hard surface. Damage to the probe could result.

The shipping carton should contain the following components:

- Viscosity Sensor in its Chamber
- MXT Electronics Enclosure
- Cabling
- Instruction Manual
- Optional Equipment

Installation Requirements

The explosion-proof AST, Model AST101, must be installed to comply with the relevant requirements of the National Electrical Code (ANSI/NFPA 70) for US installations, the Canadian Electrical Code (CSA C22.1) for Canadian installations and in accordance with IEC 60079-14 for ATEX approved installations.

NOTE: Only the Viscosity Sensor is approved for use in a hazardous area. See Appendix C for approval information.

The viscosity sensor must be installed in a manner that will optimize its performance. The installation requirements are:

- Provide a continuous product stream to the viscometer with a minimum time lag between the viscometer location and point of changes.
- The AST Sensor Cable should not be installed through the same conduit as AC line voltage. Use separate conduit. Do not run cable past line voltage terminals.

NOTE: Sensor must be rinsed clean after use. This is accomplished as part of the system cleaning. If material is allowed to dry out on the sensor, it may affect the proper operation of the unit.

- Install the viscometer so that it is always full of fluid. Mounting is recommended as shown in Figure 2-1. Avoid pipe configurations that allow air or solids to collect in the Sensor Chamber, as the viscometer only measures the viscosity of fluid located around the probe sensor.
- To avoid damage to the viscosity sensor, it should be installed after a filtering device or screen.
- For ATEX Installations, enclosure must be sealed at the conduit opening with a suitably rated Ex db IIB, Ex tb IIIC cable gland.

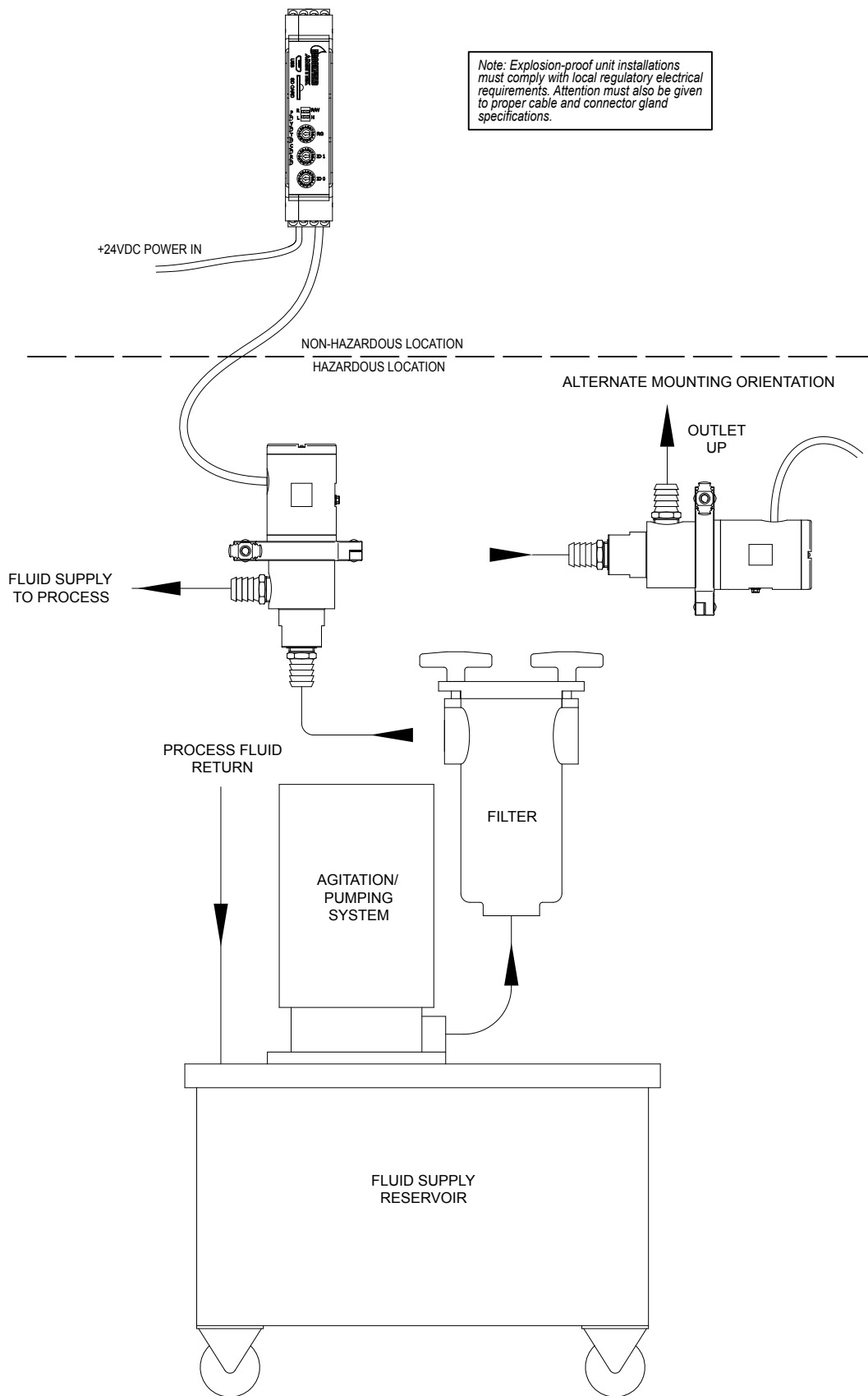



Figure 2-1: Typical FAST-10X System

Installation

Cleaning

To ensure proper operation of the viscometer, it is important to flush clean the sensor once the operation has been shut down. Do not allow material to dry out on the sensor or it may not work properly. If the sensor is flushed clean as part of the system cleaning procedure, it will continue to operate accurately.

 **CAUTION:** The user should ensure that the substances placed under test do not release poisonous, toxic or flammable gases at the temperatures which they are subjected to during the tests.

 **CAUTION:** Do not exceed the Temperature or Pressure ratings of the system during cleaning. Care should be taken to ensure that all cleaning materials are compatible with the elastomeric o-rings in the probe housing.

 **CAUTION:** If this instrument is used in a manner not specified by the manufacturer, the protection provided by the instrument may be impaired.

TERMINAL CONNECTIONS
ON BOTTOM OF
ELECTRONICS ENCLOSURE

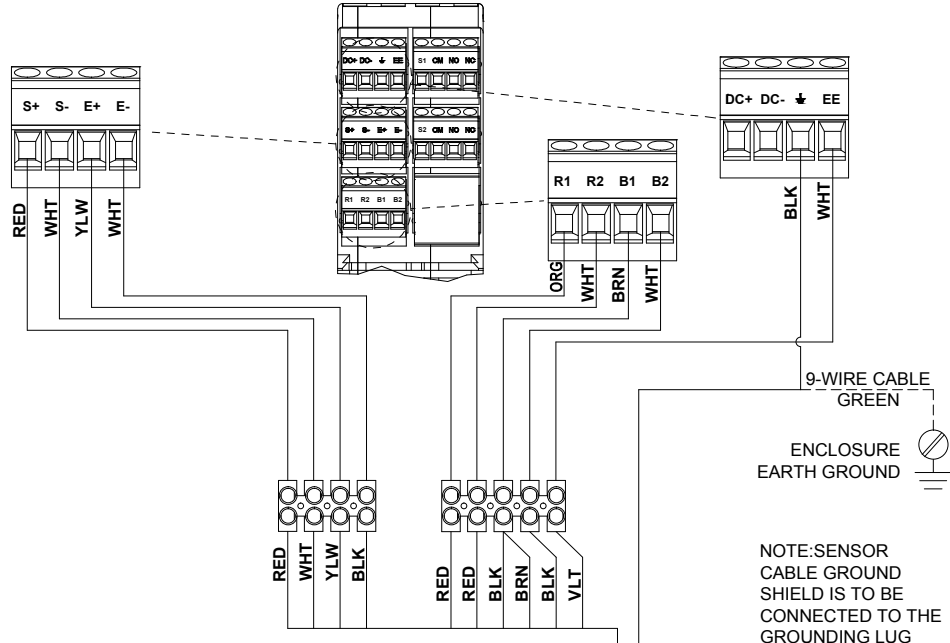

PROBE	VPV1-105x 9-WIRE CABLE	AST-395x 10-WIRE CABLE	ELECTRONICS ENCLOSURE
VISCOSITY	RED	RED (PAIR 3)	S+
	WHITE	WHITE (PAIR 3)	S-
	YELLOW	YELLOW (PAIR 5)	E+
	BLACK	WHITE (PAIR 5)	E-
TEMPERATURE	RED	ORANGE (PAIR 4)	R1
	RED	ORANGE	R2
	BLACK/BROWN	BLUE	B1
	BLACK	BROWN	B2
EEPROM	VIOLET	N/A	EE
GROUND	GREEN	BLACK (PAIR 1)	⏚

MUST BE SEALED
WITHIN 18" (46 cm)
1/2-14 NPT
(FOR ATEX, CONDUIT MUST
BE SEALED AT ENCLOSURE,
WITH Ex db IIb, Ex tb IIIC
CABLE GLAND.)

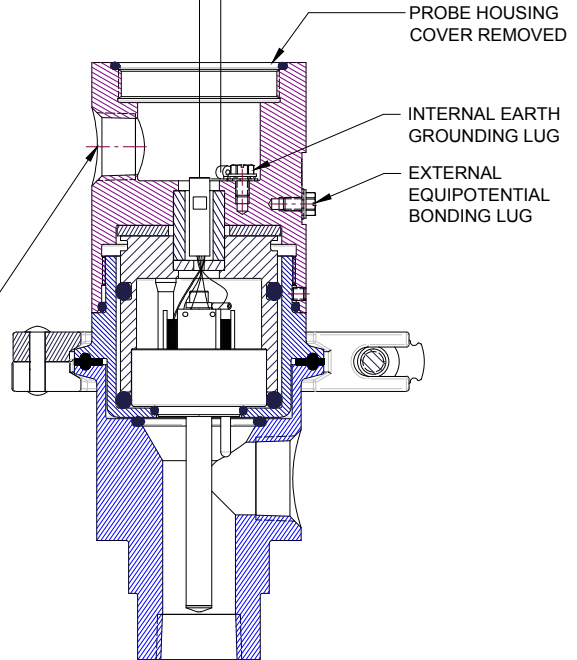

NOTE: Installation must comply with local regulatory electrical requirements. Attention must also be given to proper cable and connection/gland specifications.

Note: Negative terminal is earth grounded and max. impedance is 1000 Ω.

Figure 2-2: Terminal Connection

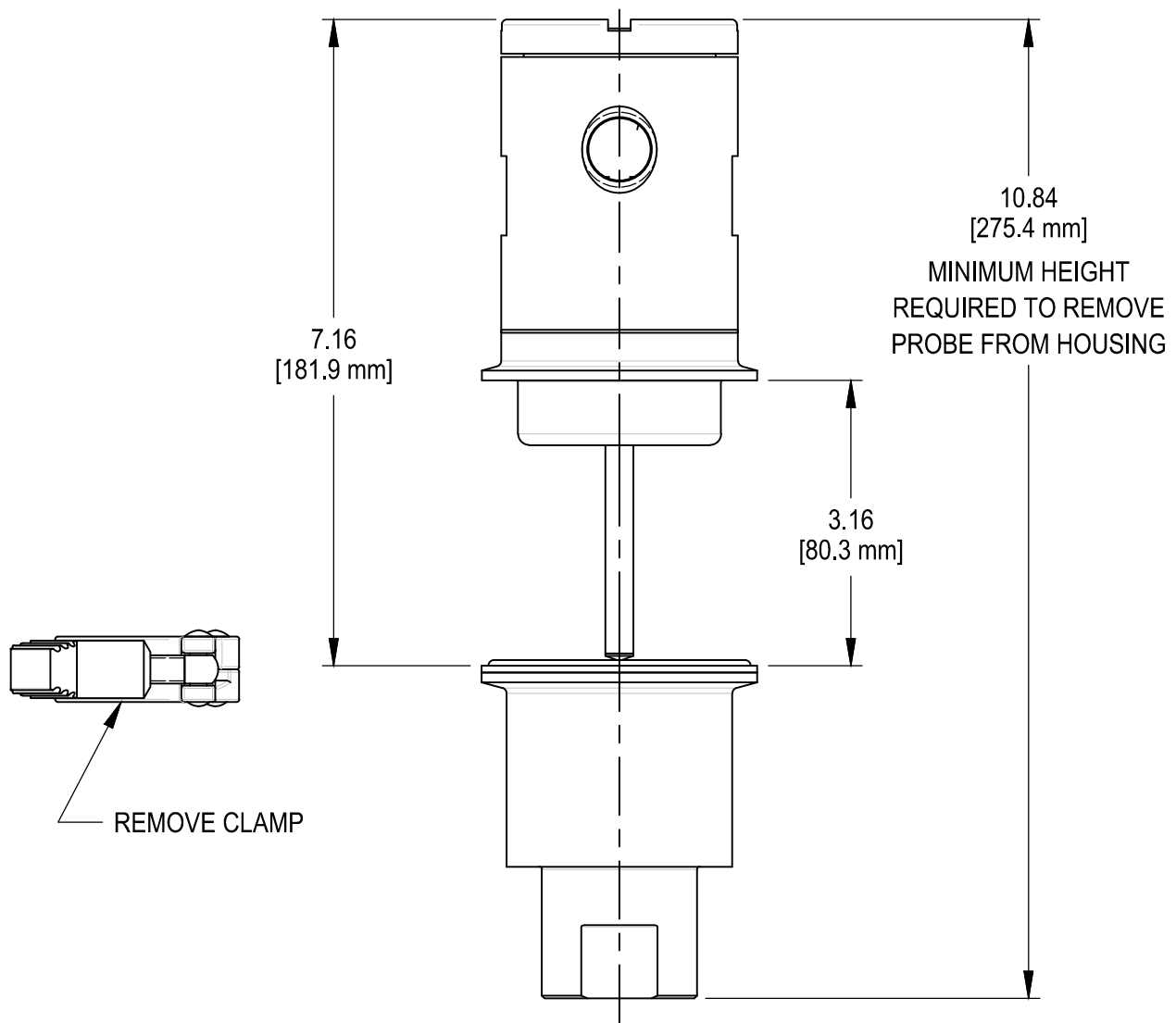

Figure 2-3: FAST-10X Installation Clearance

NOTE: Take precaution not to allow the sensing probe to come in contact with any hard surface. Damage to the probe could result.

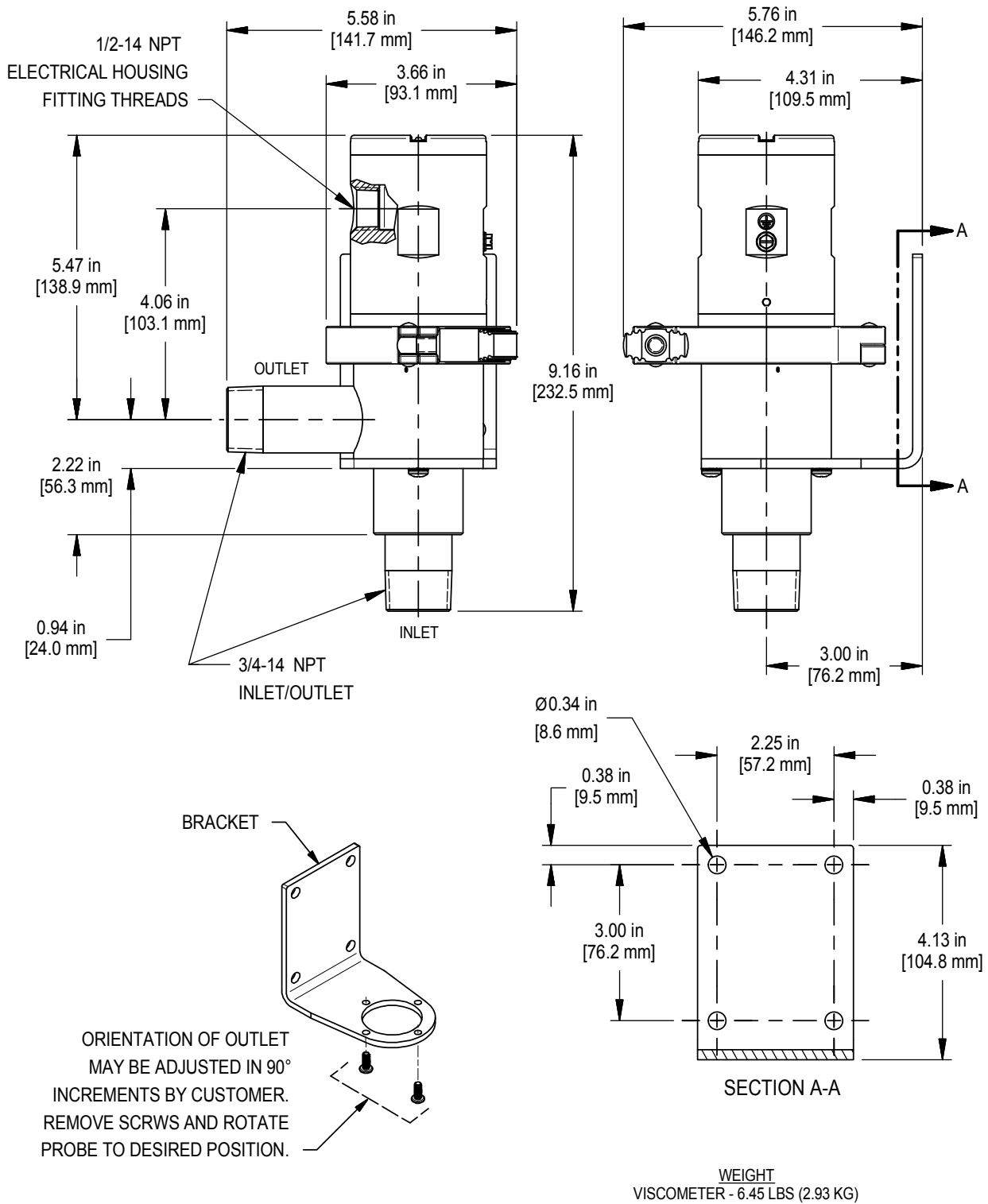

Figure 2-4: FAST-10X (Male Chamber) Bracket Mounting and Clearance

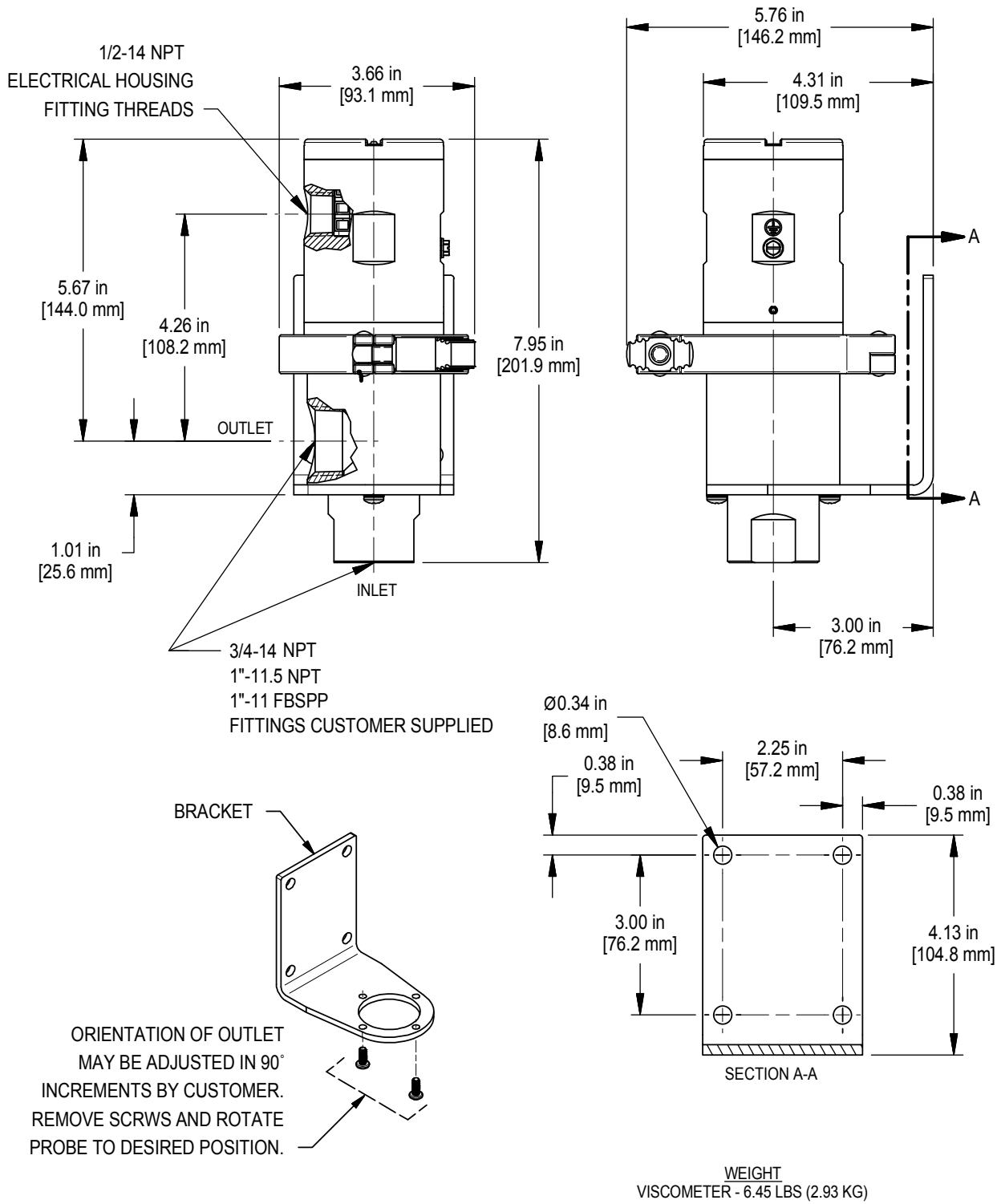

Figure 2-5: FAST-10X (Female Chamber) Bracket Mounting and Clearance

Section 3 - Operation

Operation

Once installation is completed, applying power to the FAST-10X will automatically transfer the probe data from the FAST-10X EEPROM to MXT memory. Once this operation is complete, the system will automatically begin measuring the viscosity of the sample.

The viscosity will be displayed on the User's Display Meter, PLC or similar device. There are no user adjustments required for normal operation. Should it be necessary to adjust the 4-20mA output range, refer to the MXT Manual (M16-5909).

Section 4 - Maintenance

Cleaning in Place

The solvent used for cleaning the viscometer is dependent upon the process fluid being measured. It may be preferable to isolate the section of pipe in which the viscometer is installed from the main process system.

1. Drain the process fluid from the system or isolated section of pipe in which the viscometer is installed.
2. Fill the system, or isolated section of pipe in which the viscometer is installed, with cleaning fluid.
3. The instrument should flush clean along with normal process piping.
4. The instrument should be flushed clean prior to any extended downtime to avoid product buildup.

NOTE: Cleaning duration varies by the amount of process fluid build-up and its cleaning characteristics.

5. Drain the cleaning fluid from the system or isolated section of pipe in which the viscometer is installed
6. Refer to *Section 3 - Operation* and perform the Start-up procedure.

NOTE: In addition to these instructions, ATEX approved installations must be maintained in accordance to IEC 60079-19.

NOTE: Throughout this procedure take precautions not to allow the sensing probe to come in contact with any hard surfaces. Damage to probe could result.

Section 5 - Service

Introduction

The Viscosity Sensor is a highly reliable and rugged unit that requires little maintenance. This section provides information on component replacement.

To order replacement parts, refer to Appendix A and contact Brookfield. When ordering replacement assemblies, make sure that all associated components (gaskets, O-rings, etc.) have been ordered to ensure the new assemblies can be properly installed.

 **CAUTION:** The internal components of the viscometer must be empty of process fluid, clean, and free of obstructions before it can be serviced. Refer to Section 4 - Maintenance and perform the cleaning procedure for the process fluid application.

NOTE: In addition to these instructions, ATEX approved installations must be maintained in accordance to IEC 60079-19.

Instrument Repair Procedure and Guidelines

In the event that your Process Viscometer should require factory maintenance, Brookfield has provided the following guidelines and recommendations to follow to ensure a prompt turn around time for all repaired items.

Before returning any Brookfield Process Viscometer, please contact our Process Service/Sales Department to obtain a Return Authorization Number. This will ensure that your instrument is routed to the proper Repair Department when received. Unnecessary delays may result when “unannounced” repairs arrive at our facility and have to be sorted and routed outside standard procedures. To contact the Process Service/Sales Department, please call 508-946-6200 or 800-628-8139 (USA Only); or you may prefer to email us at MA-MID.sales@ametech.com.

Please be sure to follow these guidelines when returning your instrument:

1. The Process Return Form received from us is completely filled out with the correct information.
2. Ensure that the SDS section of the Process Return Form is completed and any applicable SDS sheets are also included with your instrument to be repaired. Failure to comply with SDS regulations may result in repair delays.
3. Out method of return shipment is via FedEx. Should you prefer a different method or wish to charge to your carrier account number, be sure to include this information.

FAST-10X Performance Verification Test Using AST-111 Reference Fluid

The AST instrument requires no field calibration. On an annual or as needed basis, you may verify the AST to the Certificate of Test provided with the instrument.

The “Certificate of Test” will include the following:

- Certificate Number
- Model #
- Serial #
- Test Fluid
- Test Temperature
- Fluid Viscosity Uncertainty
- Test Value (cSt)

This Performance Verification Test requires that you use the same test media, namely Brookfield test fluid AST-111 held at the Test Temperature listed on the “Certificate of Test” for the duration of the test. If you are able to test the product under the above conditions and the viscosity is within +/- 3% of the Test Value the instrument is working properly.

The following describes the procedure for completing a performance verification test on any AST using AST-111 reference fluid.

NOTE: Please protect the probe at all times to prevent damage.

Procedure:

1. Remove instrument from service.
2. Check the measuring probe for damage and ensure there is no product contamination on the probe. Clean as necessary with appropriate material and prevent scratches and damage to the probe.
3. Use a container wide & deep enough to submerge the Sensing Probe without contacting the sides of the container.
4. Open the AST-111 container and mark it with the date of first use as it has a life expectancy of one year after being opened.
5. Pour an appropriate amount of the AST-111 Fluid into the container and bring it to the “Test Temperature”.
6. Submerge the Sensing Probe fully in the AST-111 Fluid, ensuring that the RTD probe is fully submerged.
7. Allow the temperature of the AST-111 Fluid & the Sensing Probe to equalize in temperature at the “Test Temperature”, which may take time if the probe came from a hot or cold environment.
8. Record the Measured Value, either from the output signals available from the transmitter, or the controller if purchased.
9. The instrument is functioning properly if the recorded value is within +/- 3% of the “Test Value” as noted on the “Certificate of Test”.
10. If the value is outside the range, please contact Brookfield for a repair authorization number and return for service.
11. If found acceptable, remove the Sensing Probe from the test container, clean excess fluid from the Probe and Probe Housing to prepare it for re-assembly into the process.
12. The AST-111 fluid can then be returned to the AST-111 container for future use. Please mark the date of first use on the container as the shelf life is one year after first use.

Appendix A - Customer Support

Introduction

Use the following information to contact Brookfield for technical assistance or service:

AMETEK Brookfield.
11 Commerce Boulevard
Middleboro, Massachusetts 02346 U.S.A.
TEL: 508-946-6200 800-628-8139 (USA only)
FAX: 508-946-6262
EMAIL: MA-MID.sales@ametek.com

Please have the following information available when calling so that we may assist you:

- Product Part Number
- Product Serial Number
- Product Application
- Specific Problem Area
- Hours of Operation
- Equipment Type

Appendix B - Warranty Information



We hereby warranty this Brookfield Viscometer to be free from defects in workmanship and materials. If found to be defective in workmanship or materials upon being returned, within one year from the date of purchase to our factory, it will be repaired or replaced at the factory without charges. Transportation charges shall be at the owner's expense.

However, if upon being so returned and after inspection, we determine that the instrument has been subjected to tampering, careless handling, improper or faulty application or installation, the above guarantee shall not be applicable and we shall have the right in any such case to make a charge to cover the cost of repairs or servicing. Brookfield assumes and shall have no liability for consequential damages resulting from the use or misuse of the instrument.

The foregoing warranty is in lieu of all other guarantees or warranties, expressed or implied, and of all other obligations or liabilities, contractual or otherwise, either to the original purchaser of said instrument or to any other person whomsoever.

Appendix C - Certification

Table D-1: Approvals for Model FAST-10X

Approval	Protection Concept
CLASS I, DIV 1, GROUPS C & D	Explosion Proof (US & CA)
CLASS II, DIV 1, GROUPS E, F, G	Dust-Ignition proof (US & CA)
CLASS III, DIV 1	Fiber & Flying Protection (US & CA)
Ex db IIB  II 2 G	Flameproof (EU - ATEX 94/9/EC)
Ex tb IIIC  II 2 D	Protection by Enclosure (EU - ATEX 94/9/EC)
NEMA 4X & IP66	Environmental Protection
T6/T85°C for Ta = 50°C / Process of -20°C to 50°C T4/T135°C for TA = 50°C / Process of -20°C to 120°C	
Hazardous Location Standards	
Conforms to UL Stds 61010-1, 50 & 50E, FM Stds 3600, 3615 & 3616 Certified to CSA Std C22.2 Nos. 61010-1, 25, 30, 94.1 & 94.2	



Installation & Maintenance Instructions

BROOKFIELD

Model MXT In-Line Transmitter Electronics



Supplied by

247able.com

Call us on +44 (0)118 916 9420 | Email info@247able.com

BROOKFIELD MODEL MXT
IN-LINE TRANSMITTER ELECTRONICS
Installation, Operation and Maintenance Instructions
Manual No. M16-5909-B1117



INSTRUMENTATION & SPECIALTY CONTROLS DIVISION
11 Commerce Boulevard, Middleboro, MA 02346 USA
TEL 508-946-6200 or **800-628-8139** (USA excluding MA)
FAX 508-946-6262 INTERNET <http://www.brookfieldengineering.com>

Table of Contents

Section 1 - MXT Transmitter	7
1.1 Introduction	7
1.2 Features and Benefits	7
1.3 Specifications	7
1.4 MXT Electronics User Interface Description	8
1.5 Safety Procedures	10
1.6 Certification Approvals and Conformity	10
1.7 Operating Ranges	10
Section 2 - Installation	11
2.1 Electrical Connections	11
2.2 Transmitter Installation	11
2.3 Wiring Connections	13
2.4 Micro SD Card Installation/Removal.....	16
Section 3 - Operation	18
3.1 Start-up Operation	18
3.2 CAN Protocol Operation	18
3.3 RS-485 Modbus RTU & CAN Features	19
Appendix A - Overall Dimensions, Mounting & Clearance	23
Appendix B - Wiring Diagrams	26
Appendix C - 4-20mA Outputs	29
Appendix D - Modbus/CAN ID	30
Appendix E - RS-485 Modbus RTU Application Parameters	31
Appendix F - CAN Commands	33
Appendix G - Cup Calibration	40
Appendix H - Status Byte Map	43
Appendix I - Resolving Status Byte Issues	44
Appendix J - Warranty Information	45
Appendix K - Customer Support & Repair	46

The information in this document is believed to be accurate and reliable. However, AMETEK Brookfield, cannot accept any financial or other responsibilities that may result from the use of this information. No warranties are granted or extended by this document.

Brookfield reserves the right to change any or all information contained herein without prior written notice. Revisions may be issued at the time of such changes and/or deletions.

Any duplication of this manual or any of its parts without expressed written permission from Brookfield is strictly prohibited.

Any correspondence regarding this document should be forwarded to:

AMETEK Brookfield
Process Viscometer Division
11 Commerce Boulevard
Middleboro, Massachusetts 02346
U.S.A.
Telephone: (508) 946-6200
FAX: (508) 946-6262
Internet: <http://www.brookfieldengineering.com>

The following Brookfield trademarks and service marks may appear in this document:

All other trademarks or registered trademarks are the property of their respective holders.

Section 1 - MXT Transmitter

1.1 Introduction

The Brookfield Model MXT Transmitter is a highly versatile transmitter that processes the fluid viscosity signal from any model AST Viscosity Sensor.

The system shown in Figure 1-1 can be used in a variety of industrial applications where the viscosity of chemicals, coatings, inks, and many other process fluids must be monitored.

1.2 Features and Benefits

The MXT Transmitter incorporates the following features:

- Easy start-up and operation
- Instantaneous response
- Wide viscosity range
- Multiple output signal options
- Versatile and easy to Use
- cSt, cP, Cup-Sec viscosity readings
- Read/write stability parameters
- Error/status messages
- Optional dry contact relays

The MXT is offered in models as follows. The MXT can also be used as a direct replacement for all AST-100T and AST-100D model Transmitters used on AST-100 /101 /102 viscosity control systems.

MXT Model Number Naming Convention

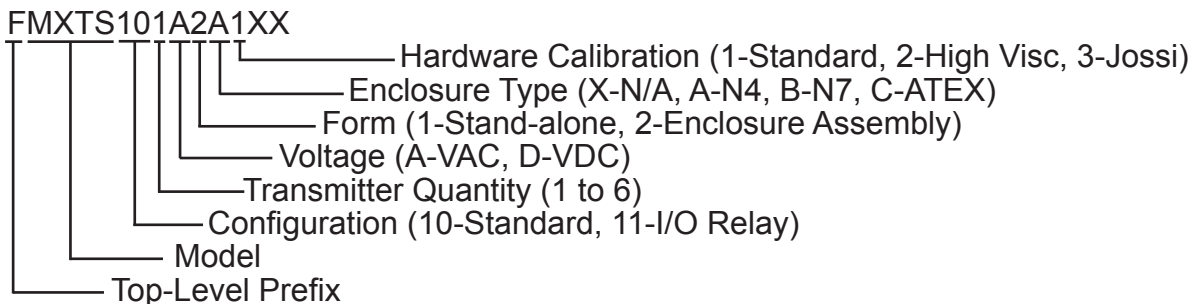

1.3 Specifications

Table 1-1: VAC Transmitter Specifications

Qty of MXT Transmitters	1-2	3-4	5-6
Maximum Power Consumption	40 VA	80 VA	120 VA
Input Fuse Rating *	1A	2A	4A
Input Voltage	85-264 VAC		
Input Line Frequency	47-63 Hz		



* Both L1 and L2 terminal blocks are provided with 5x20 mm, Slow Blow (Time Delay) fuses. Replace with equivalent.

Table 1-2: VDC Transmitter Specifications

Maximum Current	1A per MXT
Input Voltage	18-30 VDC

Table 1-3: Enclosure Specifications

Enclosure Type	NEMA Type 4 (IP 66 Equivalent)
Operating Temperature Range	32°F to 122°F (0°C to 50°C)
Relative Humidity Range	20-80% Non-condensing

Table 1-4: Optional Relay Specifications

Relay Type	Dry Contact Relay (SPDT)
Voltage Range	5-30 VDC or 5-250 VAC
Maximum Current	2 A
Lamp Load	30 W DC / 200 W AC
LED	Green when Closed

1.4 MXT Electronics User Interface Description (Refer to Figure 1-1)

USB

Micro-USB B port for reading viscosity and temperature. Communication parameters are the same as the RS-232 output.

SD Card

The viscometer sensor calibration data is available on a replaceable Micro-SD Card. If the sensor is replaced, carefully insert the Micro-SD Card with the new calibration data (if not using a sensor with integrated EEPROM).

Dip Switches

Switch Position	RS-485 Modbus RTU Baud Rate [bps]	CAN Bit Rate [kbps]
L	9600	125
H	38400	250

Rotary Switches

RG - 4-20 mA Output Range (refer to Appendix C)

ID 1 - Modbus Slave/CAN Node ID - Digit #1

ID 0 - Modbus Slave/CAN Node ID - Digit #2

Examples:

Required ID#: 01

ID 1 Switch: 0

ID 0 Switch: 1

Required ID#: 30

ID 1 Switch: 1

ID 0 Switch: E

See Appendix D for decimal to hexadecimal conversions.

Status LEDs

(P) Power LED - Solid green when power is on and self-test is passed. Showing green/red for in progress self-test. Solid red if self-test failed.

(V) Viscosity Range LED - Solid green when viscosity 4-20 mA output is <20 mA. Solid red when viscosity 4-20 mA output is ≥ 20 mA

(T) Temperature LED - Solid green when RTD OK and in range. Solid red if disconnected. Orange when connected but out of range.

(C) Communication LED - Green for receive. Red for sending.

(R) Remote Sensor Status LED - Solid green when probe is found. Blinking green for in progress connecting to probe. Solid red if no probe is detected.

Relay LEDs (Optional model which includes 2 Relay outputs)

RLY 1 & 2 LEDs - Solid green when relay contact is closed.

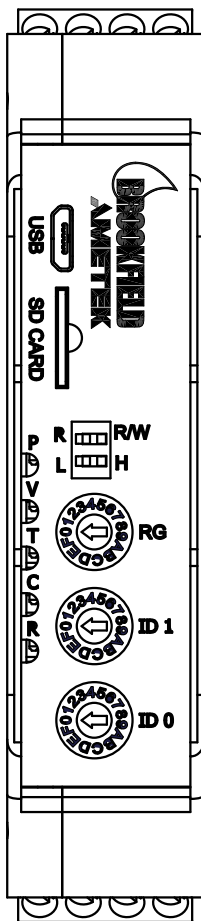



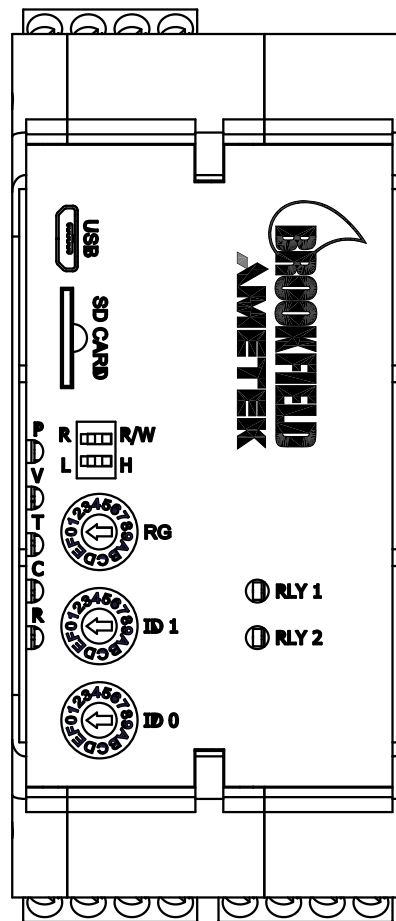



MXT (Standard)



MXT I/O RELAY

Figure 1-1: User Interface

1.5 Safety Procedures

-  Hazardous voltages present. Disconnect mains voltage before servicing.
-  This instrument must be properly earth grounded to guard against personal injury and electronics failure!
-  If this instrument is used in a manner, not specified by the manufacturer, the protection provided by this instrument may be impaired.
-  This instrument is not intended for use in a potentially hazardous environment.
-  In case of emergency, remove the power to the unit
-  The safety of any system incorporating the equipment is the responsibility of the assembler of the system.

NOTE: This transmitter is not intended for outdoor use.

1.6 Certification Approvals and Conformity

The MXT transmitter has been tested and is certified to the following CE standards:

Emissions - EN 55011:2009+A1:2010 Class A for radiated and mains conducted emissions.

Immunity - EN 61326-1:2013 Immunity for industrial and light industrial equipment.

Safety (Low Voltage Directive) - EN 61010-1:2010
Safety requirements for electrical equipment for measurement, control, and laboratory use. Part 1: General requirements.

For a CE Declaration of Conformity, please contact a sales representative and request a copy for your records.

WARNING: Compliance may be compromised if the unit is not installed as specified in the manual.

1.7 Operating Ranges

Viscosity range: 2 to 3,300 cSt (1 to 12,000 cSt available)
Temperature range: -20°C to 120°C (-4°F to 248°F), up to 200°C (392°F) available

Note: Both the temperature and viscosity noted above are limited by the AST-100 viscometer chosen. Please review the AST-100 instrument specification sheet for more details and limitations.

Section 2 - Installation

2.1 Electrical Connections

The MXT Transmitter requires the following to operate:

Table 2-1: MXT VDC Utilities

Input Voltage	18-30 VDC		
Input Wiring	+24 VDC	-24 VDC	Ground (Earth)
MXT Terminal Block Connections	+DC	-DC	

Table 2-2: MXT VAC Utilities

Input Voltage	85-264 VAC		
Input Frequency	47-63 Hz		
Input Wiring	L1 Hot (Live)	L2 (Neutral)	Ground (Earth)
MXT Terminal Block Connections	L1	L2	5

2.2 Transmitter Installation

The MXT Electronics are designed to be small in size and installed onto a standard DIN rail. The MXT Electronics are housed in an open type enclosure. It is required that you install the electronics in a housing, cabinet, or electric control room.

The MXT Electronics are designed for natural convection cooling. For proper cooling, you must mount the electronics vertically as shown in Appendix A and provide a clearance of at least 1 in (25 mm) above and below the device. Also, allow at least 1 in (25 mm) of depth between the front of the module and the inside of the enclosure. If mounting multiple Electronics on the same DIN rail, clearance for cooling is not necessary between each module.

To remove the MXT Electronics from the DIN rail, take a flat bladed screwdriver and insert the tip into the latch hole. Pull the spring-loaded latch down and away from the DIN rail while rotating the module off the DIN rail. Refer to Figure 2-1.

 **Caution:** Electrostatic discharge can damage the MXT Electronics. Ensure that you are properly grounded prior to touching the electronics.

Warning: Installation or removal of the MXT Electronics with the power applied could cause electric shock or damage to the equipment. Always follow appropriate safety precautions and ensure that power is disabled before attempting to install or remove the equipment.

Transmitter models which include an enclosure should be mounted in a vertical position for proper cooling of internal electronic components. Ensure that the wall of the mounting

surface can support the weight of the transmitter safely. The transmitter enclosure have the following size and weight specifications:

Table 2-3: Transmitter Enclosure Specifications

MXT Qty	Transmitter Qty	Height in [mm]	Width in [mm]	Depth in [mm]	Weight lb [kg]
1-2		7 [178]	7 [178]	6.7 [117]	9 [4.1]
3-4		10 [254]	8.5 [216]	6.7 [170]	14 [6.4]
5-6		12 [305]	10 [254]	6.7 [172]	20 [9.1]

See Appendix A: Mounting & Clearance Drawings for mounting hole locations and size.

Note: The MXT Electronics Enclosures are NOT APPROVED for use in hazardous areas.

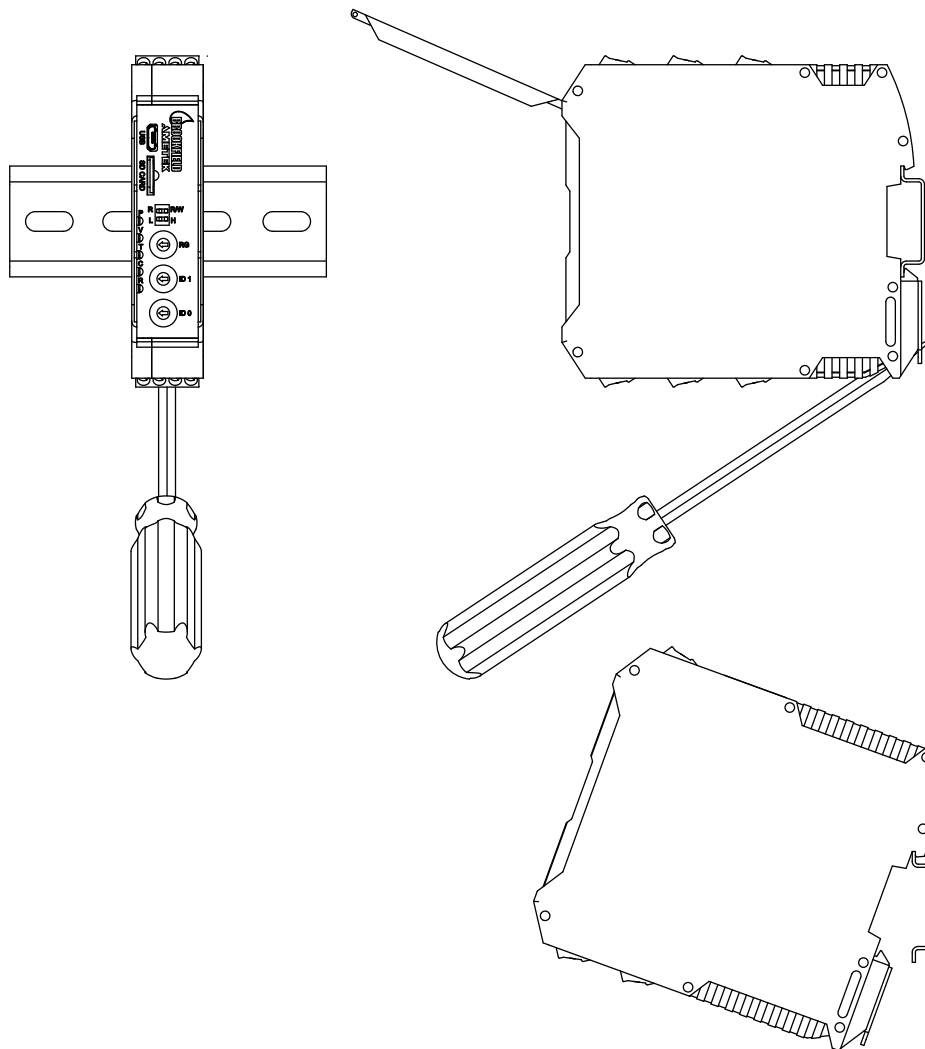

Figure 2-1: Electronics Removal

2.3 Wiring Connections

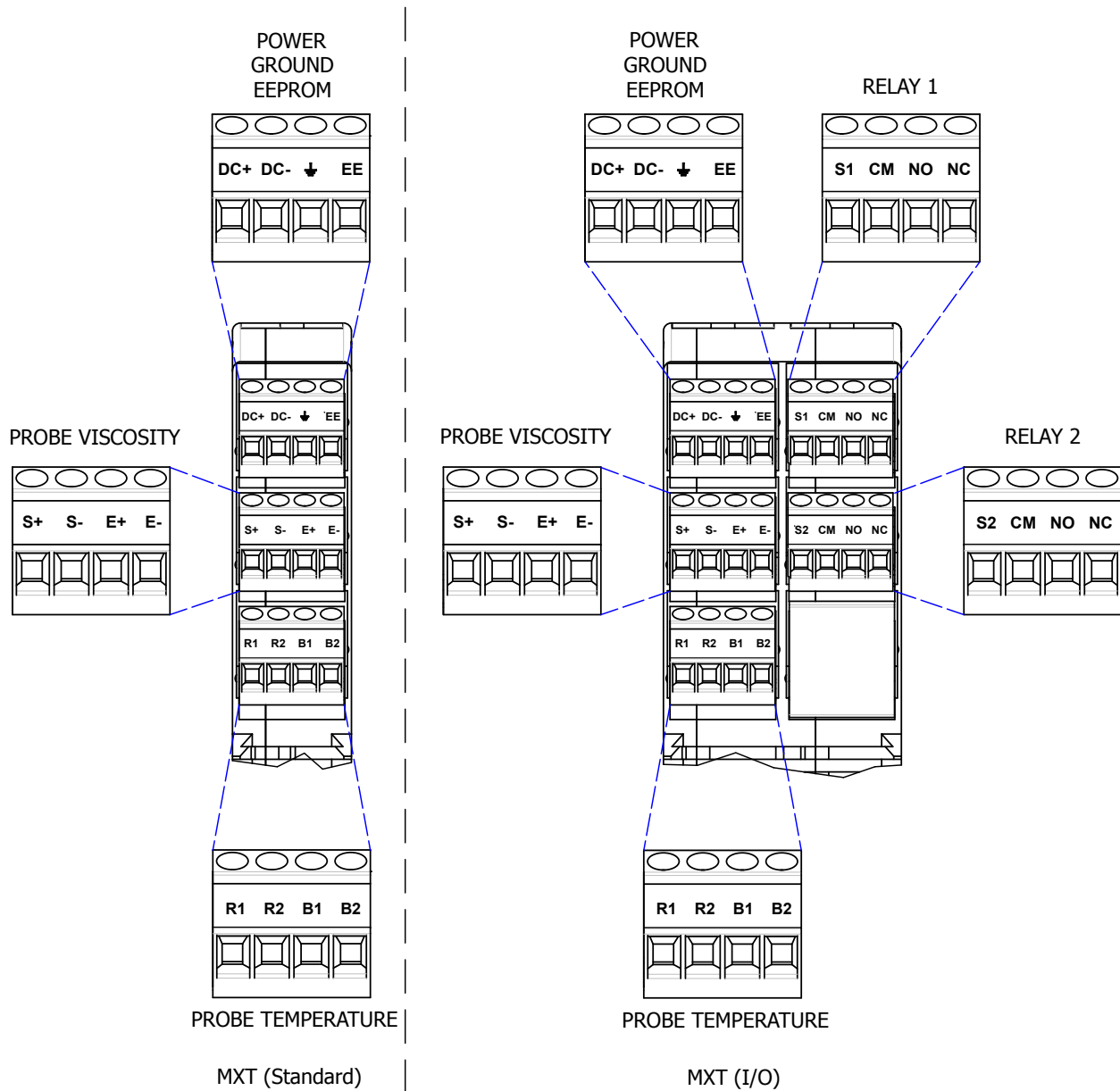
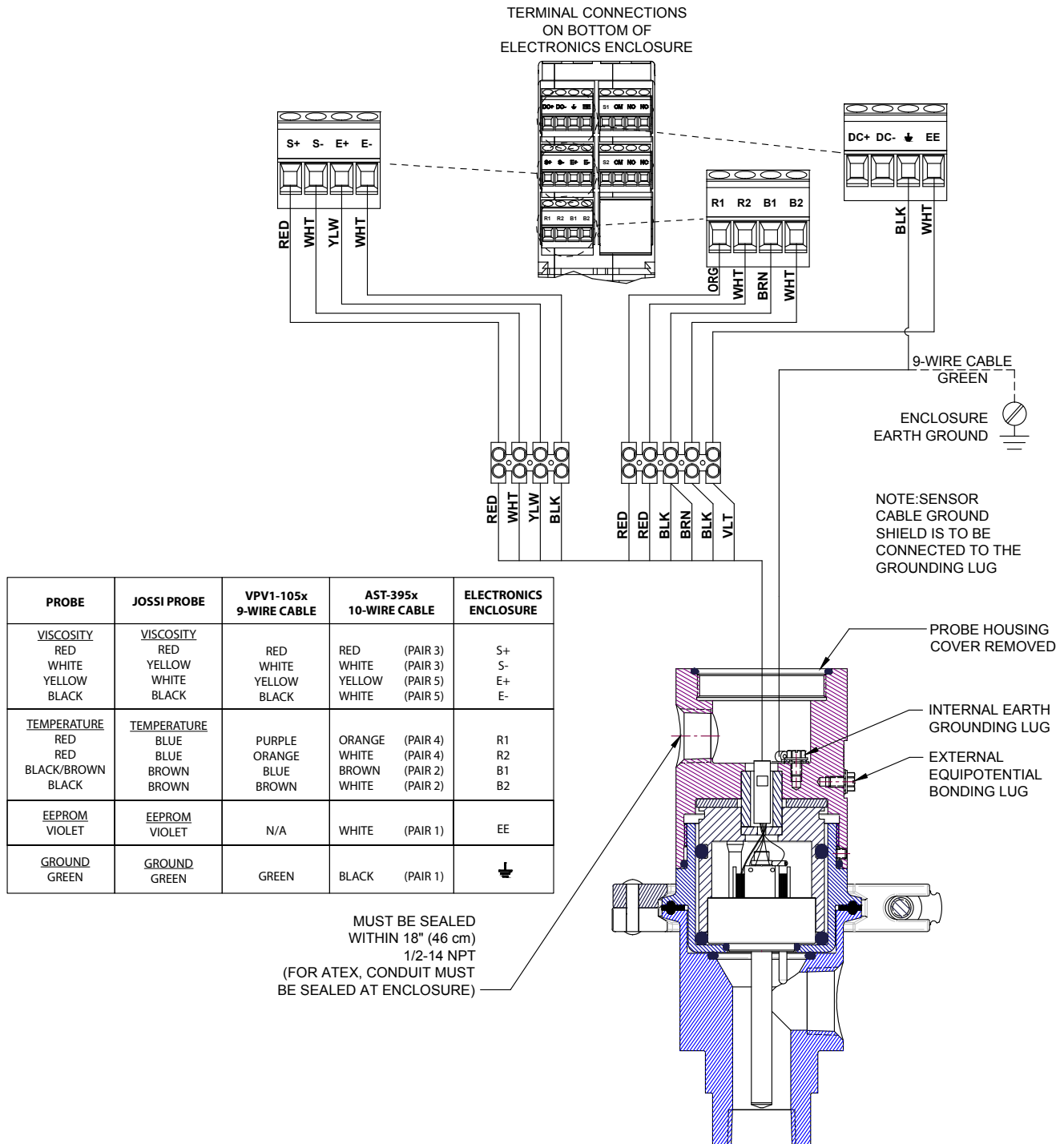

Figure 2-2: Power, Viscosity, Temperature, Relay Terminal Blocks

Viscosity Sensing Probe Hook-Up

There are nine wires and a Sensing Cable Ground/Shield coming from the Viscosity Sensor to the electronic enclosure. The Viscosity Probe Terminal Blocks are labeled S+, S-, E+ and E-. The RTD Terminal Blocks are labeled R1, R2, B1, and B2. Figures 2-2 and 2-3 show the connections. The Sensing Cable Ground/Shield wire can be connected to the ⚡ terminal block or terminated to the Panel Ground Stud. Refer to Figure 2-3.

Note: The sensing cable should not be installed through the same conduit as line voltage. Use separate conduit. Do not run cable past line voltage terminals.



NOTE: Installation must comply with local regulatory electrical requirements.
Attention must also be given to proper cable and connection/gland specifications.

NOTE: Negative terminal is earth grounded and max. impedance is 1000 Ω.

Figure 2-3: Terminal Connections

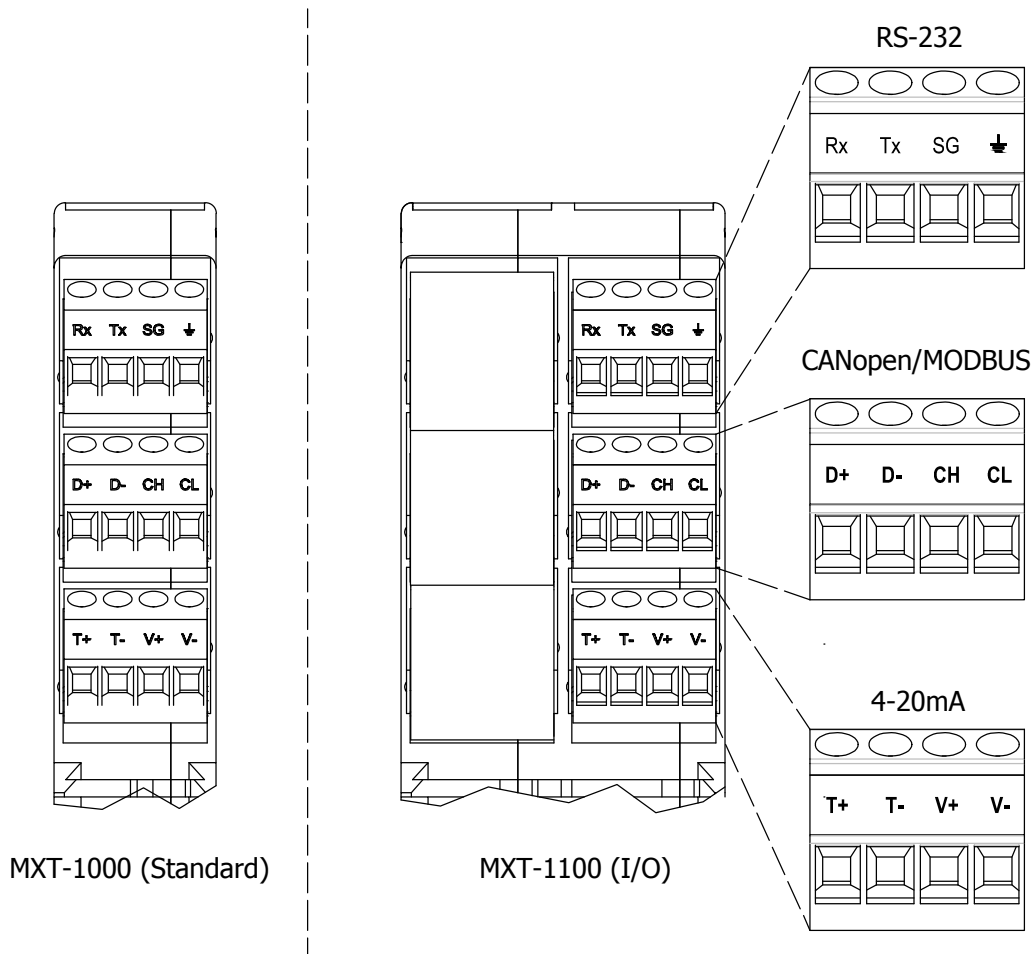

Figure 2-4: Output Terminal Blocks

RS-232 Output

The RS-232 Output Terminal Blocks are labeled RX, TX, SG and ⏏ . Refer to Figure 2-4.

- RX - Receive
- TX - Transmit
- SG - Signal Ground
- ⏏ - Earth Ground

- USB/RS-232 Port Settings
- Bits Per Second: 9600
 - Data Bits: 8
 - Parity: None
 - Stop Bits: 1
 - Hand-Shaking: None

- Format
- V: 9999.99
 - T: 120.0 <CR> <LF>
 - Viscosity in cstk
 - Temperature in °C

RS-485 Modbus RTU Output

The RS-485 Output Terminal Blocks are labeled D+, D-, SG and ⏏ . Refer to Figure 2-4.

- D+ - +
- D- - -
- SG - Signal Ground
- ⏏ - Earth Ground

Protocol: MODBUS RTU
Baud Rate: 9600 / 38400 (switchable) (Default setting 9600, Low/High switch in left position)
Data Bits: 8
Parity: None
Stop Bits: 1

NOTE: See Appendix E for Modbus Register Parameters.

4-20mA Output

The milliamp output Terminal Blocks are labeled T+, T- for the temperature output and V+, V- for the viscosity output. See Appendix C for settings. Refer to Figure 2-4.

 **Caution:** The 4-20mA outputs are active. Applying an external voltage source will damage the electronics.

CAN Output

The CAN output Terminal Blocks are labeled CH, CL, and SG. Refer to Figure 2-4. See Appendix F for CAN register parameters.

CH - CAN High
CL - CAN Low
SG - Signal Ground

Note: Connect line termination resistors at each end of the bus to minimize signal reflection. The impedance of the termination should be 120 Ω (5%, 1/4W max) connected between terminal block CH and CL.

Optional Relays

The optional dry contact relay Terminal Blocks are labeled CM, NO and NC. Connections can be made for either Normally Open or Normally Closed operation. Refer to Figure 2-2. See Appendix E for Modbus RTU register parameters.

Relay Switches 1 & 2

CM - Common
NO - Normally Open
NC - Normally Closed

2.4 Micro SD Card Installation/Removal

Follow ESD Guidelines (e.g. wear a grounded wrist strap) when you handle the SD Card. Store the calibration SD Card in a conductive container.

 **Caution:** Electrostatic discharge can damage the MXT Electronics. Ensure that you are properly grounded prior to touching the electronics.

Warning: Installation or removal of the MXT Electronics with the power applied could cause electric shock or damage to the equipment. Always follow appropriate safety precautions and ensure that power is disabled before attempting to install or remove the equipment.

Before inserting a calibration SD Card, ensure that the MXT is powered down. Position the SD Card so the the notch faces toward the LEDs (toward the bottom of the electronics enclosure) and the copper contacts face away from the AMETEK Brookfield Logo (see Figure 2-4). Gently press the SD Card into the spring loaded socket until it is fully seated. A tamper-proof calibration seal is provided loose for application to the clear cover after the installation is complete.

Warning: Do not apply excessive force when inserting the SD Card into the electronics. This could cause damage to the Printed Circuit Board and/or the mating socket.

For removal of the SD Card, take a small flat blade screwdriver and carefully press the SD Card in the semi-circular cutout and then remove the screwdriver. The spring loaded receptacle will push the SD Card up for removal.

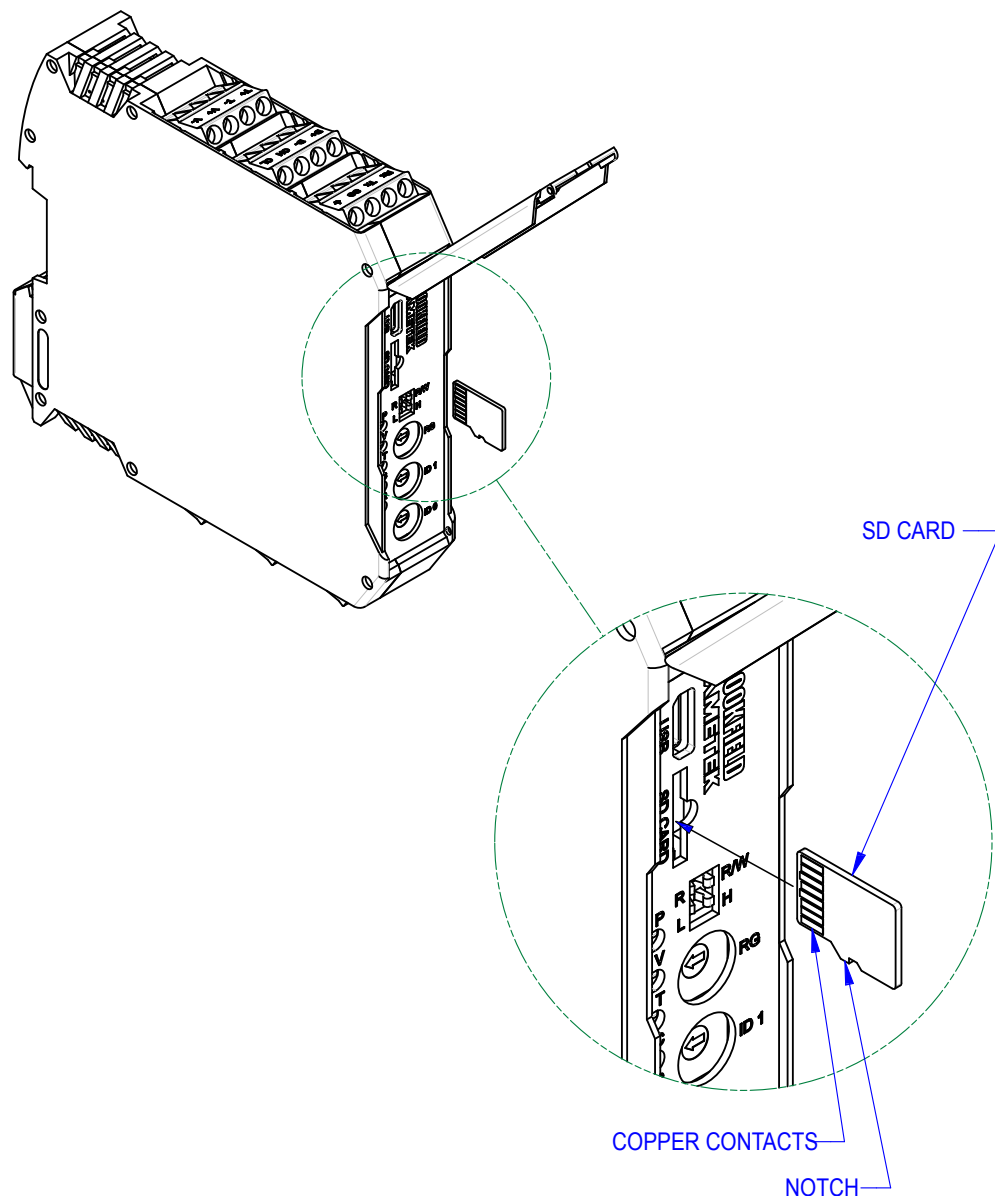

Figure 2-5: Proper Insertion of SD Card

Section 3 - Operation

3.1 Start-up Operation

Once installation is completed, applying power to the MXT Transmitter will automatically transfer the probe data from the EEPROM to memory. Once this operation is complete, the MXT will automatically begin measuring the viscosity of the sample.

The viscosity will be displayed on the User's Display Meter, PLC or similar device. There are no user adjustments required for normal operation. Should it be necessary to adjust the output range, refer to Appendix C for the correct position of the range switch (RG) located on the front User Interface.

Note: Adjustment of the Range Select (RG) will only scale the 4-20mA Viscosity Output.

Temperature range and RS-232 and RS-485 outputs are automatically scaled within the electronic circuitry.

3.2 CAN Protocol Operation

Overview

The MXT provides a CAN interface through which parameters can be adjusted and values are reported. Besides viscosity in centiStokes (cSt), the device automatically reports viscosity in cup-seconds (cup-sec) and centiPoise (cP), and temperature in Celsius (°C).

Note: See Appendices E & F for details of all commands referred to in the following description, as well as error and status information.

Modes

The MXT powers up in the Pre-Operational Mode. In this mode, parameters can be adjusted, but the device is not reporting data. Once the Master sets the MXT into Operational Mode, the device begins reporting viscosity and temperature readings at one second intervals. Parameters can also be adjusted while in the Operational Mode.

Transmit Process Data Objects (TPDOs)

During Operational Mode, by default, the device sends 4 TPDOs each second:

- TPDO #0: Viscosity in cSt and Viscosity Status;
- TPDO #1: Viscosity in cP and Viscosity Status;
- TPDO #2: Viscosity in cup-sec and Viscosity Status;
- TPDO #3: Temperature in °C and Temperature Status.

If desired, the Master can turn off TPDOs while the device is in Pre-Operational Mode. If a TPDO is turned off, that data will not be reported when the device is switched to Operational Mode. Power cycling the device resets all TPDOs to on.

3.3 RS-485 Modbus RTU & CAN Features

Viscosity Reading Stability

There are two parameters which are used to determine if the MXT viscosity readings are Stable: Stability Criteria and Array Size. The Stability Criteria specifies how much the readings can vary (max - min, in cSt) over a given amount of time. The Array Size specifies this amount in time (sec). Since the readings are taken once per second, Array Size also specifies how many points will be examined when determining stability.

The Array is emptied whenever the device is first powered up or the Array Size is changed. The reading is not considered Stable until the Array is filled. Only after the Array is full will the MXT calculate Stability. Both Full and Stable are recorded in the Viscosity Status Bytes.

By default, the Stability Criteria is set to 500 cSt, and the Array Size is set to 60 sec. Both parameters can be adjusted to reflect the typical behavior of the process fluid and what is acceptable for the user's process.

Viscosity in Centipoise

Density is used in the calculation of Viscosity in cP, using the following equation:

$$V_{cP} = V_{cSt} * \rho \quad [1]$$

The factory default value for Density will be 0.9 g/cm³. The user will be warned that they should set the Density value to the density of their process fluid, to make the VcP readings more accurate.

Cup-Sec Conversion

The MXT can report Viscosity in cup-sec, according to the user's chosen cup. In order for the device to do this, the user must first calibrate the device to the specific cup and process fluid. See Appendix G for a flowchart of the Cup Calibration process.

Before the user can perform a Cup Calibration, the readings must be Stable. If the user sends a T2 value while the readings are not Stable, the MXT will report Cup Calibration Error in the Viscosity Status. Once the readings are Stable, the user should set the Cup Index to their cup type (see Appendix G). The user then takes a reading of the process fluid using the specified cup, and sends this value to the device as T2.

As soon as the device receives a T2 value, it will take a corresponding V2 reading (Viscosity in cSt). This will be the second point used in the 2-point calibration. The first point is at Viscosity = 0 cSt. The T1 value will be calculated using the second degree polynomial cSt/cup-sec conversion model, with the theoretical K and C values for the chosen cup type (see Appendix G):

$$V = KT - C/T \quad [i]$$

Setting V1 = 0 and solving for T1 gives:

$$T_1 = \sqrt{C/K}$$

The V and T values from the theoretical point 1 and the measured point 2 are then used in two instances of equation [i]:

$$\begin{aligned} V_1 &= KT_1 - C/T_1 \\ V_2 &= KT_2 - C/T_2 \end{aligned}$$

Solving these simultaneous equations (with $V_1 = 0$) gives:

$$K_{adj} = (V_2 * T_2) / (T_2^2 - T_1^2)$$

Solving equation [i] for C gives:

$$C_{adj} = (K_{adj} * T_2^2) - (V_2 * T_2)$$

These adjusted K and C factors are then used to convert the cSt values of that particular MXT to the cup-sec readings of the user's specific cup and process fluid. Using the quadratic equation to solve equation [i] for T (Vcup) gives:

$$V_{cup} = (V_{cSt} + \sqrt{(V_{cSt}^2 + 4 * K_{adj} * C_{adj})}) / (2 * K_{adj})$$

The MXT will perform these calculations as soon as a T2 value is received. Once the Cup Calibration is successful, the MXT will record in the Viscosity Status Bytes that the device is Calibrated.

If the cup being used is not one of the cups listed in Appendix G, the Custom Cup option can be used. In order to use the Custom Cup option, the user needs to know the K and C constants used in the above conversion model [i] for that cup. These constants can usually be obtained from the manufacturer of the cup. These K and C values will be sent to the device as K_{cust} and C_{cust} . K_{cust} and C_{cust} will be used as the starting theoretical K and C in the above calibration process.

To perform a Cup Calibration using a Custom Cup, the Cup Index should be set to 0, and the K_{cust} and C_{cust} value should be set, before the T2 reading is sent. If the user sends a T2 value for a Custom Cup (Cup Index = 0), but either K_{cust} and C_{cust} are 0, the MXT will report Cup Calibration Error in the Viscosity Status.

When the device is powered up, the Viscosity in cup-sec will read 0.0 until a Cup Calibration is performed. Once a Cup Calibration is performed, the device will report cup-sec values based on this calibration. If the device is power cycled, the cup-sec readings will revert back to 0.0 unless the parameters were saved to non-volatile memory.

Adjusting Application Parameters

The following parameters can be adjusted: Cup Index, K_{cust} , C_{cust} , T1, T2, Stability Criteria, Array Size, and Density. Cup Index, K_{cust} , C_{cust} , T1 and T2 are used in the Cup Calibration (see Cup-Sec conversion above). Stability Criteria and Array Size are used to determine whether readings are Stable (see Viscosity Reading Stability above).

Density is used in the calculation of Viscosity in cP. It should be noted that, by default, a Density of 0.9 g/cm³ is used when converting Viscosity in cSt to Viscosity in cP. If the actual density of the liquid is significantly different than 0.9 g/cm³, the Viscosity in cP readings will be inaccurate until the Density is adjusted to a more accurate value.

The new value of any adjusted parameter will be used by the device until it is powered down. At power up, the device will revert to the parameter values in non-volatile memory. If the user would like to change the default value of a parameter, so that the device uses this value even after power cycling, they can do so by using the Parameter Save command. The user should adjust any parameters they wish to save, then send one Parameter Save command. Parameters marked as EEPROM=Y in Appendices E & F are saved to non-volatile memory. Note, however, that this command should only be used when necessary to change default values. Excessive overuse of this command may shorten the life of the internal memory component.

Optional Relays

Relay operation is only functional through the Modbus RTU protocol. There are 4 modes available for the optional relays.

- Mode 0 - OFF
- Mode 1 - ON
- Mode 2 - Single Shot
- Mode 3 - Timed Cycle

Single Shot Time

- Time period for timed output in unit of 0.01 sec. Range 2.00 sec to 655.35 sec.
- Single Shot On Time in unit of 0.01 sec. Range 2.00 sec to 655.35 sec.

Duty cycle - % On (relay closed) time over the timed period is in 0.01% unit. For example:

- 0.00% = off all time
- 100.00% = on all time
- 25.00% & Time = 4.00 sec then on 1 sec & off 3 sec

Power up default:

- Mode = 0 (OFF)
- Time = 20.00 sec
- Duty cycle - 0.00%

Operation Logic:

- Single Shot (Mode = 2)
 - Mode changes from (0, 1 or 3) to 2 - turn relay off and wait for write to Time registers
 - A write to Time register triggers the one shot relay action
 - If the Time register is <2.00 sec, then not relay action will be taken
 - If the relay is on (closed) from the previous one shot Time register write, then the new trigger will be ignored and leave the relay to finish the previous one shot action

- Timed Cycle (Mode = 3)
 - Mode changes from (0, 1 or 2) to 3 - reset timed period to start and apply duty cycle value
 - Any change in period value (exclude setting the same period value) - reset timed period to start and apply duty cycle value
 - Any new duty cycle value will apply at the start of the next period. The current timed period should be completed with the old value
 - Time period of <2.00 sec, the Relay will stay off (open)

Appendix A - Overall Dimensions, Mounting & Clearance

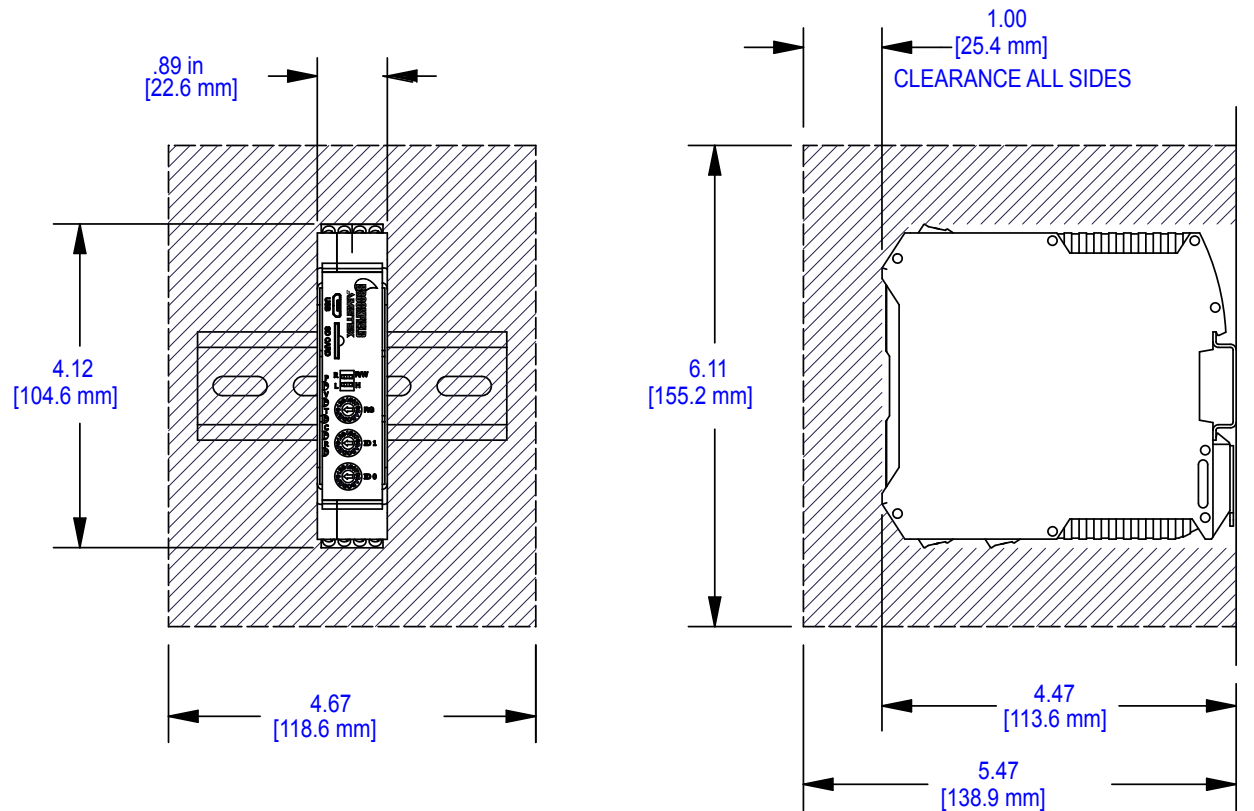

Figure A-1a: MXT Overall Dimensions and Clearance Zones

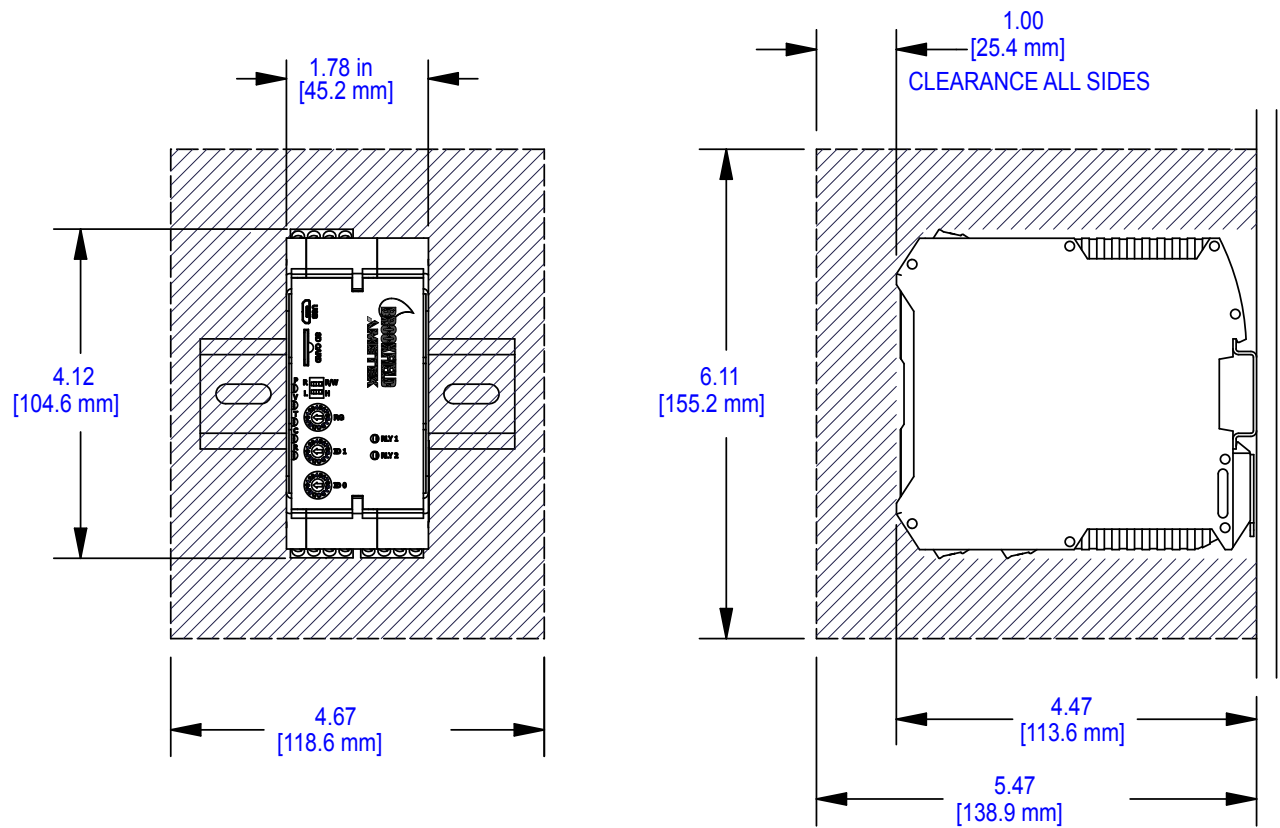
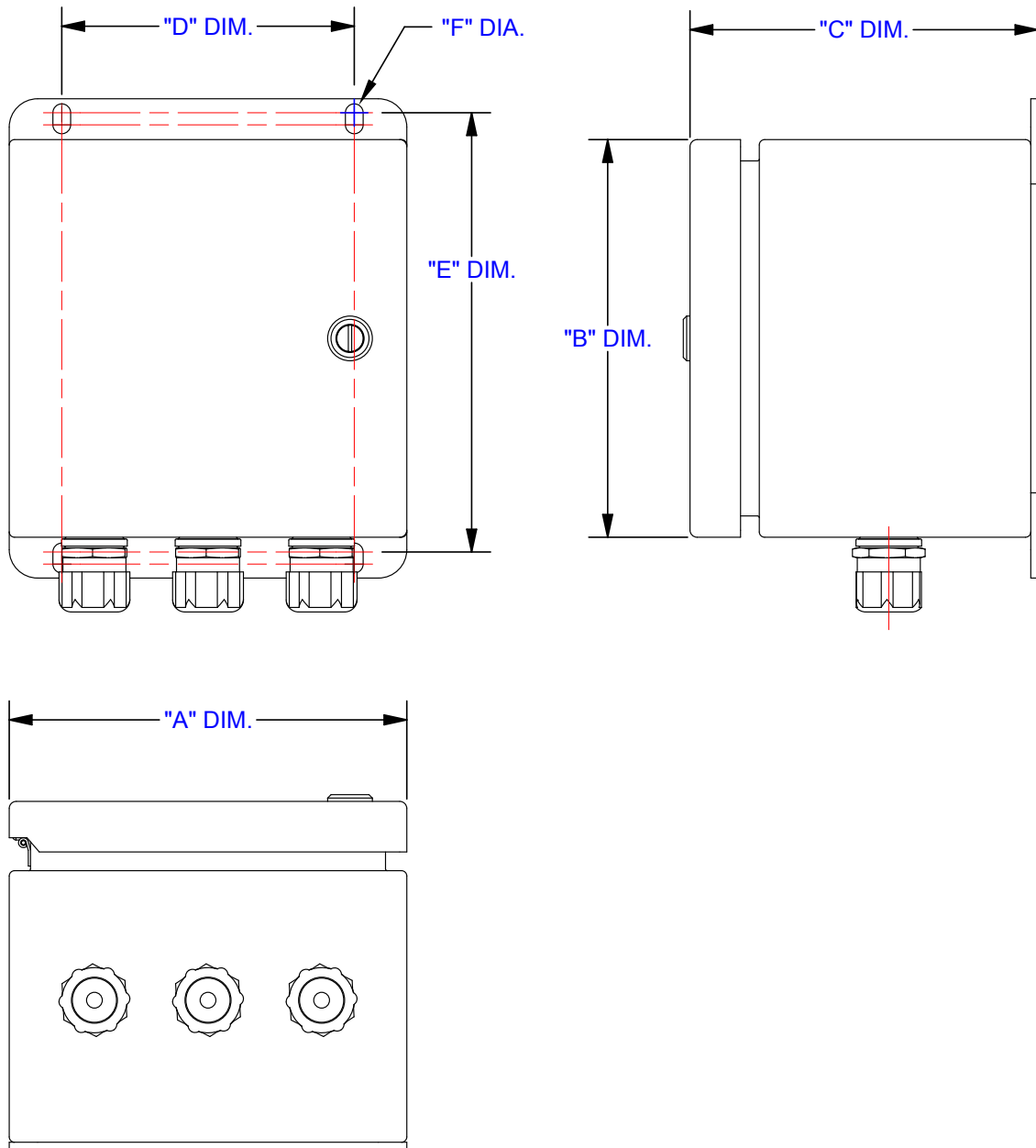

Figure A-1b: MXT I/O Overall Dimensions and Clearance Zones



ENCLOSURE	"A" DIM.	"B" DIM.	"C" DIM.	"D" DIM.	"E" DIM.	" F" DIA.
MXTS101-2	7"	7"	6 11/16"	5 5/16"	7 3/4"	Ø5 5/16 SLOT
MXTS103-4	8 1/2"	10"	6 11/16"	6 1/2"	10 3/4"	Ø5 5/16 SLOT
MXTS105-6	10"	12"	6 3/4"	8"	12/3/4	Ø5 5/16 SLOT

**Figure A-2: MXT Enclosure
Mounting and Clearance Dimensions**

Appendix B - Wiring Diagrams

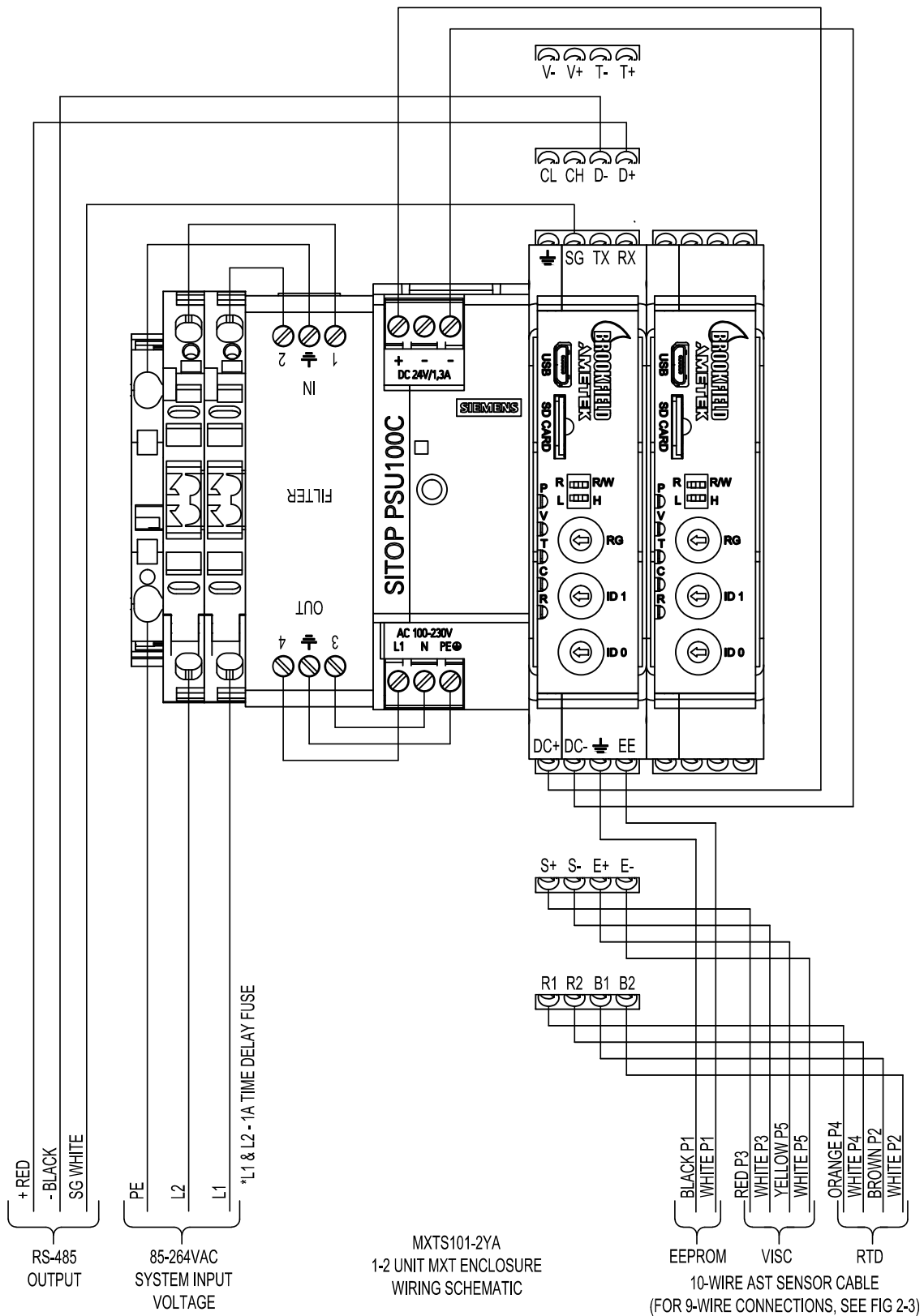

Figure B-1: 1-2 Unit MXT Enclosure Wiring Schematics

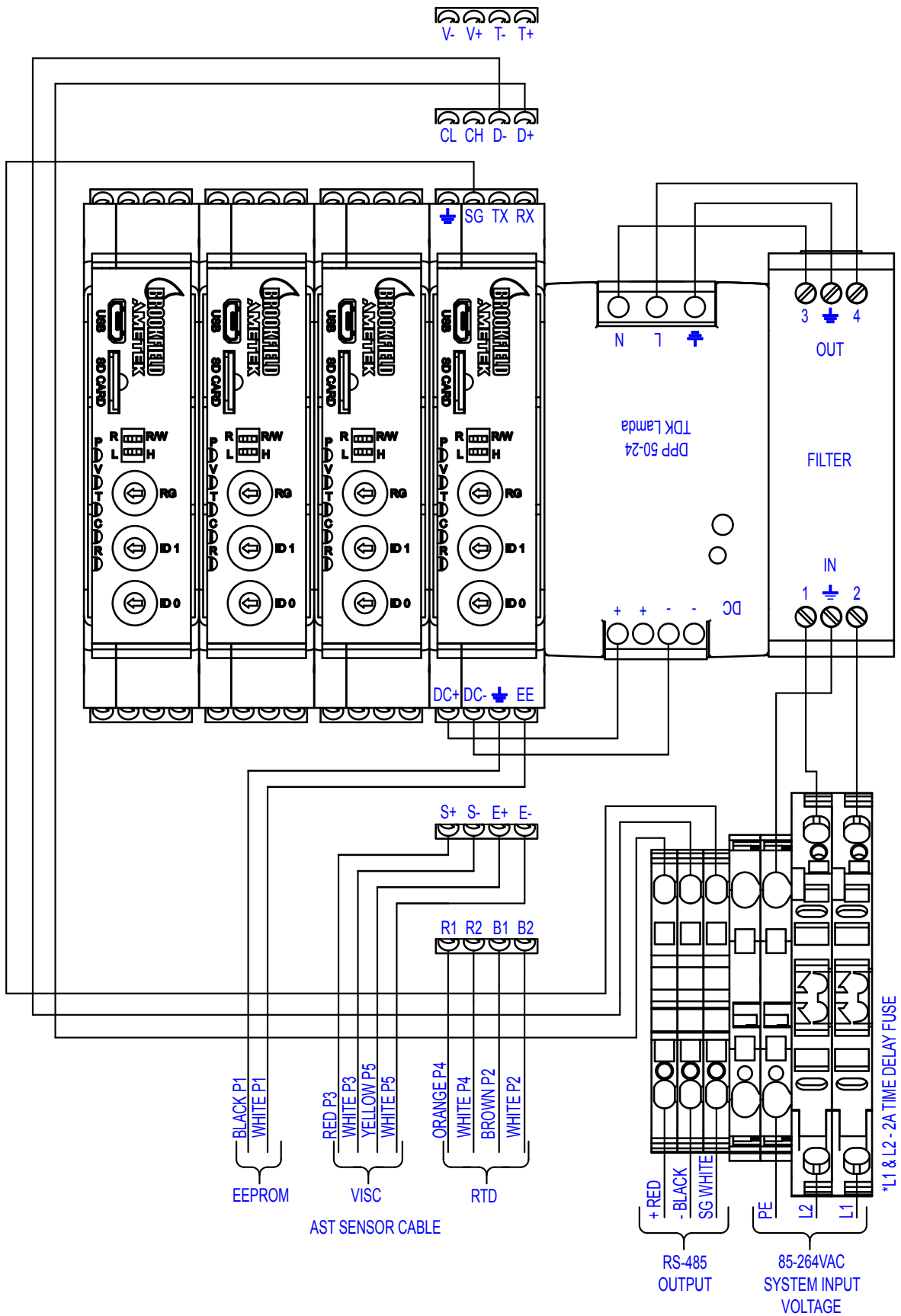

Figure B-2: 3-4 Unit MXT Enclosure Wiring Schematics

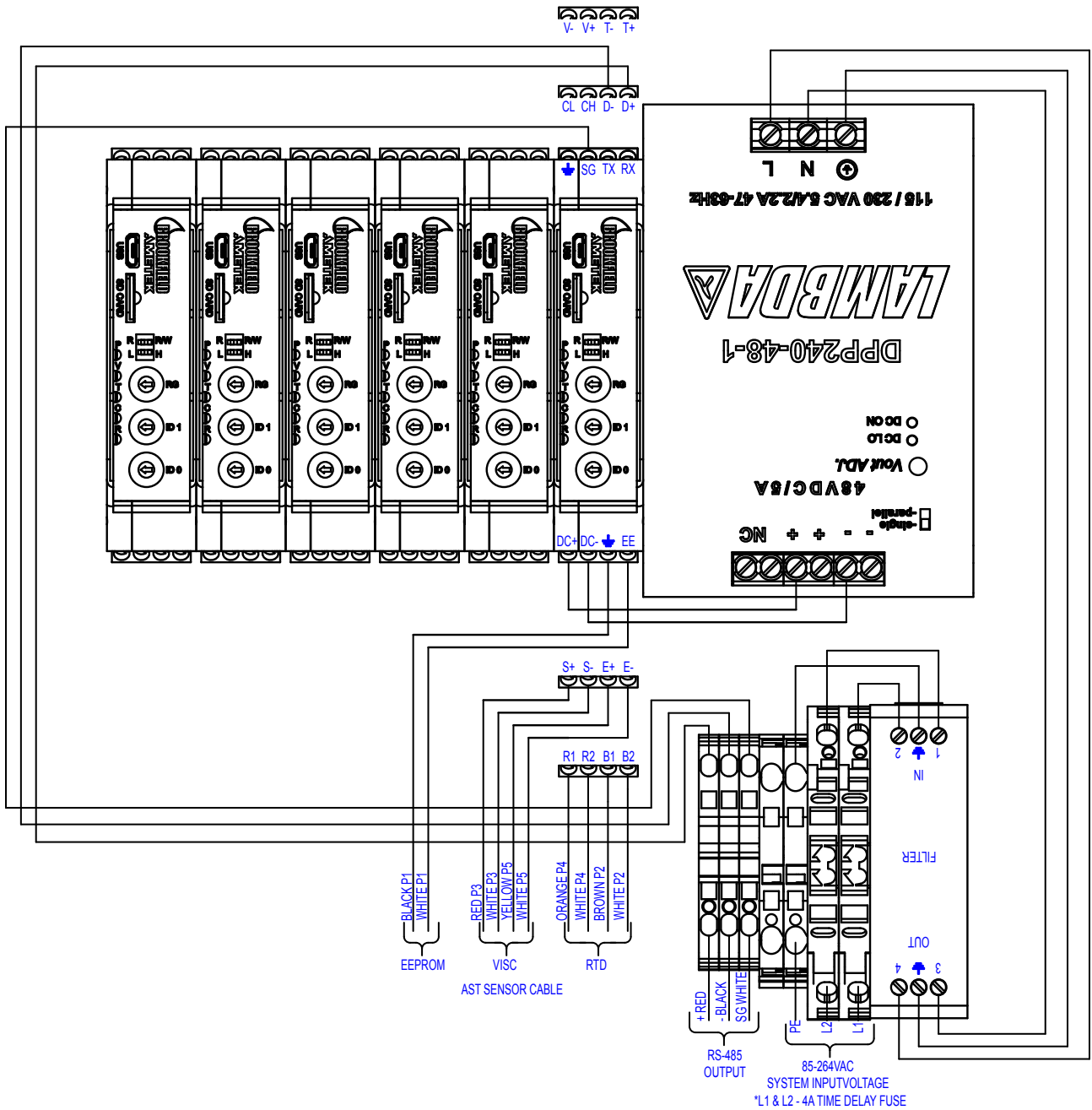

Figure B-3: 5-6 Unit MXT Enclosure Wiring Schematics

Appendix C - 4-20mA Outputs

Table C-1: MXT Viscosity mA Output Range

Viscosity milli-Amp Output (see Figure 1-2)

Range #	Low Limit (= 4mA)	High Limit (= 20mA)
0	0 cSt	10 cSt
1	0 cSt	50 cSt
2	0 cSt	100 cSt
3	0 cSt	250 cSt
4	0 cSt	500 cSt
5	0 cSt	1000 cSt
6	0 cSt	1500 cSt
7	0 cSt	2000 cSt
8	0 cSt	3300 cSt
9	custom	custom
A-F	not used	

Temperature milli-Amp Output

4 mAmps Equivalent	20 mAmps Equivalent
-20°C	+150°C

Notes:

1. Scaling between the 4 and 20mA limits is linear.
2. There is no calibration of the milli-Amp output required. All values are set digitally within the controller.
3. Resolution limit is approximately 1600 data points between the 4 and 20mA.
4. The mAmp output for temperature is always in degrees Celsius.

Appendix D - Modbus/CAN ID

Table D-1: Decimal to Hexadecimal Conversion

DEC	HEX	ID 1 SWITCH	ID 0 SWITCH
0	0	0	0
1	1	0	1
2	2	0	2
3	3	0	3
4	4	0	4
5	5	0	5
6	6	0	6
7	7	0	7
8	8	0	8
9	9	0	9
10	A	0	A
11	B	0	B
12	C	0	C
13	D	0	D
14	E	0	E
15	F	0	F
16	10	1	0
17	11	1	1
18	12	1	2
19	13	1	3
20	14	1	4
21	15	1	5
22	16	1	6
23	17	1	7
24	18	1	8
25	19	1	9
26	1A	1	A
27	1B	1	B
28	1C	1	C
29	1D	1	D
30	1E	1	E

Appendix E - RS-485 Modbus RTU Application Parameters

Table E-1

Name	Description	Data Type	Range	Default	Access	EEPROM	Modbus
Save Parameters	Once value 0xEE2C is written to address 0x700, Application Parameters are saved to non-volatile memory	U16	0xEE2C	0	WO	Y	0x 700
Viscosity Status	See Status Bit Map	U16	0-0xFFFF	0	RO	N	0x 300
VcSt	Viscosity in centiStokes	REAL32	>= 0	0	RO	N	0x 302, 0x 1F2, 0x 1F6, 0x 1FC
VcP	Viscosity in centiPoise	REAL32	>= 0	0	RO	N	0x 304
Vcup	Viscosity in Cup-Seconds	REAL32	>= 0	0	RO	N	0x 306
Density	The density [g/cm ³] used to convert from VcSt to VcP	REAL32	0-10	0.9	RW	Y	0x 308
Array Size	Size of the array used for testing stability and updating the viscosity	U16	2-1000	60	RW	Y	0x 400
Stable Criteria	The largest acceptable Delta	REAL32	1-5000	500	RW	Y	0x 402
Counter	Current count of viscosity readings in the array	U16	1 to array size	0	RO	N	0x 404
Delta	Difference between the highest and the lowest viscosity reading currently within the array	REAL32	>= 0	0	RO	N	0x 406
Cup Index	Index of the cup (see Cup Table). The index determines the initial K and C values used for Cup Calibration	U16	0-46	0 (= CUSTOM)	RW	Y	0x 500
Kcust	Initial K value used in the Cup Calibration if a custom cup is used (Cup Index = 0)	REAL32	>= 0	0	RW	Y	0x 502
Ccust	Initial C value used in the Cup Calibration if a custom cup is used (Cup Index = 0)	REAL32	>= 0	0	RW	Y	0x 504
V2	Average Viscosity reading in cSt which is recorded at the time that T2 is received. Used in Cup Calibration.	REAL32	>= 0	0	RO	Y	0x 506
T2	User-entered viscosity value in Cup-seconds. Used in Cup Calibration.	REAL32	>= 0	0	RW	Y	0x 508
V1	Average Viscosity reading in cSt which is recorded at the time that T1 is received. Used in Cup Calibration.	REAL32	>= 0	0	RO	Y	0x 50A
T1	User-entered viscosity value in Cup-seconds. Used in Cup Calibration.	REAL32	>= 0	0	RW	Y	0x 50C
Kadj	Final K value from the Cup Calibration. Used to convert VcSt to Vcup.	REAL32	>= 0	0	RO	Y	0x 50E
Cadj	Final C value from the Cup Calibration. Used to convert VcSt to Vcup.	REAL32	>= 0	0	RO	Y	0x 510
Temp Status	See Status Bit Map	U16	0-0xFFFF	0	RO	N	0x 600
T°C	Temperature in Celsius	REAL32	-20°C to +220°C	0	RO	N	0x 601, 0x 1F0

Name	Description	Data Type	Range	Default	Access	EEPROM	Modbus
T°F	Temperature in Fahrenheit	REAL32	-20°C to +220°C	0	RO	N	0x 603
T°K	Temperature in Kelvin	REAL32	-20°C to +220°C	0	RO	N	0x 605
Mode	Relay 1 Mode	U16	0-3	0	RW	Y	0x 180
Time Period	Relay 1 Time Period, in 0.01 secs	U16	200-65535	2000	RW	Y	0x 181
Duty Cycle	Relay 1 Duty Cycle, in 0.01%	U16	0-10000	0	RW	Y	0x 182
Mode	Relay 2 Mode	U16	0-3	0	RW	Y	0x 183
Time Period	Relay 2 Time Period, in 0.01 secs	U16	200-65535	2000	RW	Y	0x 184
Duty Cycle	Relay 2 Duty Cycle, in 0.01%	U16	0-10000	0	RW	Y	0x 185

U16 - Unsigned integer, one 16 bit register, 2 bytes, high byte first
REAL32 - Floating point number, two 16 bit registers, 4 bytes, little-endian, high byte first

Appendix F - CAN Commands

Table F-1: CAN Commands

Operation	Command Sent from Master			Response from MXT-1000			Data Type	Range	Default
	CAN-ID	Length	Data	CAN-ID	Length	Data			
Set to Pre-Operational Mode	000	2	80 nn						
Set to Operational Mode	000	2	01 nn						
Receive Viscosity (cSt) / Status				180+nn	6	vv vv vv ss ss	REAL32 / U16		
Receive Viscosity (cP) / Status				280+nn	6	vv vv vv ss ss	REAL32 / U16		
Receive Viscosity (cup-sec) / Status				380+nn	6	vv vv vv ss ss	REAL32 / U16		
Receive Temperature (°C) / Status				480+nn	6	vv vv vv ss ss	REAL32 / U16		
Turn Viscosity (cSt) OFF	600+nn	8	23 00 18 01 83 01 00 C0	580+nn	8	60 00 18 01 00 00 00 00			
Turn Viscosity (cP) OFF	600+nn	8	23 01 18 01 83 02 00 C0	580+nn	8	60 01 18 01 00 00 00 00			
Turn Viscosity (cup-sec) OFF	600+nn	8	23 02 18 01 83 03 00 C0	580+nn	8	60 02 18 01 00 00 00 00			
Turn Temperature (°C) OFF	600+nn	8	23 03 18 01 83 04 00 C0	580+nn	8	60 03 18 01 00 00 00 00			
Set Cup Index	600+nn	8	2F 00 23 00 vv 00 00 00	580+nn	8	60 00 23 00 00 00 00 00	U8	0-45	0
Set Kcst	600+nn	8	23 01 23 01 vv vv vv vv	580+nn	8	60 01 23 01 00 00 00 00	REAL32	>= 0	0
Set Ccst	600+nn	8	23 01 23 02 vv vv vv vv	580+nn	8	60 01 23 02 00 00 00 00	REAL32	>= 0	0
Set T2 (cup-sec)	600+nn	8	23 02 23 02 vv vv vv vv	580+nn	8	60 02 23 02 00 00 00 00	REAL32	>= 0	0
Set T1 (cup-sec)	600+nn	8	23 02 23 04 vv vv vv vv	580+nn	8	60 02 23 04 00 00 00 00	REAL32	>= 0	0
Set the Stable Criteria (cSt)	600+nn	8	23 00 22 02 vv vv vv vv	580+nn	8	60 00 22 02 00 00 00 00	REAL32	1-5000	500
Set Array Size (sec)	600+nn	8	2B 00 22 01 w vv 00 00	580+nn	8	60 00 22 01 00 00 00 00	U16	2-1000	60
Set Density (g/cm ³)	600+nn	8	23 00 21 05 vv vv vv vv	580+nn	8	60 00 21 05 00 00 00 00	REAL32	0-10	0.9
Save Application Parameters	600+nn	8	23 10 10 04 73 61 76 65	580+nn	8	60 10 10 04 00 00 00 00			
Read Cup Index	600+nn	8	40 00 23 00 00 00 00 00	580+nn	8	4F 00 23 00 vv 00 00 00	U8		
Read Kcst	600+nn	8	40 01 23 01 00 00 00 00	580+nn	8	43 01 23 01 vv vv vv vv	REAL32		
Read Ccst	600+nn	8	40 01 23 02 00 00 00 00	580+nn	8	43 01 23 02 vv vv vv vv	REAL32		
Read V2 (cSt)	600+nn	8	40 02 23 01 00 00 00 00	580+nn	8	43 02 23 01 vv vv vv vv	REAL32		

Table F-1 (cont.)

Operation	Command Sent from Master		Response from MXT-1000		Data Type	Range	Default
	CAN-ID	Length	CAN-ID	Length			
Read T2 (cup-sec)	600+nn	8	40 02 23 02 00 00 00 00	8	43 02 23 02 vv vv vv vv	REAL32	
Read V1 (cSt)	600+nn	8	40 02 23 03 00 00 00 00	8	43 02 23 03 vv vv vv vv	REAL32	
Read T1 (cup-sec)	600+nn	8	40 02 23 04 00 00 00 00	8	43 02 23 04 vv vv vv vv	REAL32	
Read Kadj	600+nn	8	40 03 23 01 00 00 00 00	8	43 03 23 01 vv vv vv vv	REAL32	
Read Cadj	600+nn	8	40 03 23 02 00 00 00 00	8	43 03 23 02 vv vv vv vv	REAL32	
Read the Stable Criteria (cSt)	600+nn	8	40 00 22 02 00 00 00 00	8	43 00 22 02 vv vv vv vv	REAL32	
read the Array Size (sec)	600+nn	8	40 00 22 01 00 00 00 00	8	4B 00 22 01 vv vv 00 00	U16	
Read Density (g/cm ³)	600+nn	8	40 00 21 05 00 00 00 00	8	43 00 21 05 vv vv vv vv	REAL32	
Read Temperature in °F	600+nn	8	40 00 24 03 00 00 00 00	8	43 00 24 03 vv vv vv vv	REAL32	
Read Temperature in °K	600+nn	8	40 00 24 04 00 00 00 00	8	43 00 24 04 vv vv vv vv	REAL32	

Legend: nn - device's Node ID (in hexadecimal); vv - value to be set (in the units listed, encoded according to data type). ss - Status corresponding to the reading (Viscosity or temperature). U16 - unsigned integer, one 16 bit register, 2 bytes, low byte first. REAL32 - Floating point #, two 16 bit registers, 4 bytes, little-endian, low byte first.

Table F-2: CAN Parameters, General

Name	Description	Type	Range	Default	Index	Sub	Access	EEPROM
Device Type	Describes the CANopen device profile	U32	0-0xFFFFFFFF	0 (non-standard)	0x1000	0x00	RO	Y
Error Register	CANopen internal errors	U8	0x0-FF	0	0x1001	0x00	RO	N
Manufacturer Status Register	Manufacturer defined status	U32	0-0xFFFFFFFF	0	0x1002	0x00	RO	N
Predefined Error Field	Provides a history of the device's errors. 0x00 is the number of Errors.	U8	0-255	0	0x1003	0x00	RW	N
Standard Error Field nn	Individual Error. Errors listed from newest at 0x01, down to the oldest.	U32	0-0xFFFFFFFF		0x1003	0xnn	RO	N
COB-ID SYNC message	Determines transmission priority.	U32	1-0xFFFFFFFF	0x00000080	0x1005	0x00	RW	Y
Communication Cycle Period	Interval between SYNC messages.	U32	0-0xFFFFFFFF	0x00000000	0x1006	0x00	RW	Y
Device Name	Manufacturer-supplied Device Name	String	16 Chars	'AST101'	0x1008	0x00	RO	Y
Hardware Version	Hardware Version	String	8 Chars	1.0.0	0x1009	0x00	RO	Y
Software Version	Software Version	String	8 Chars	1.0.0	0x100A	0x00	RO	Y
COB-ID EMCY	COB-ID Emergency Message	U32	1-0xFFFFFFFF	1	0x1014	0x00	RW	Y
Heartbeat Time	Producer Heartbeat Time	U16	0-65535 ms	0 (disabled)	0x1017	0x00	RW	Y
Identity Object	Identifies the device. 0x00 is the number of entries.	U8	0x01-0x04	4	0x1018	0x00	RO	N
Vendor-ID	Manufacturer ID, assigned by CiA	U32	0x000003F7	0x000003F7	0x018	0x01	RO	Y
Product Code	The type of device.	U32	0-0xFFFFFFFF	1	0x1018	0x02	RO	Y
Revision Number	Tracks changes to the functionality of the device.	U32	0-0xFFFFFFFF	0x10001	0x1018	0x03	RO	Y
Serial Number	Unique to each instance of the device.	U32	0-0xFFFFFFFF	Use probe S/N	0x1018	0x04	RO	Y

Table F-3: CAN Parameters, TPDOs #0 & #1

Name	Description	Type	Range	Default	Index	Sub	Access	EEPROM
Transmit PDO Communication Parameter #0	Defines the parameters the device can transmit. 0x00 is the number of entries.	U8	0x02-0x06	6	0x1800	0x00	RO	N
COB-ID	Communication object identifier	U32	1x0-FFFFFFFF	0x4000180 + \$NODEID	0x1800	0x01	RW	Y
Transmission Type	Specifies the transmission mode and triggering mode.	U8	0-0xFF	0xFF (Event Driven)	0x1800	0x02	RW	Y
Inhibit Time	Minimum time between attempts to transmit.	U16	0-0xFFFF	0x0000	0x1800	0x03	RW	Y
Compatibility Entry	reserved	U8	0-0xFF	0	0x1800	0x04	RW	N
Event Timer	(Event Driven) How often to transmit.	U16	0-0xFFFF	0x0E8 (1 sec)	0x1800	0x05	RW	Y
SYNC start value	Used for SYNC mode.	U8	0-0xFF	0	0x1800	0x06	RW	Y
Transmit PDO Mapping Parameter #0	Defines the parameters the device can transmit. 0x00 is the number of entries.	U8	0-0xFF	2	0x1A00	0x00	RW	N
PDO Mapping Entry _1	Mapping between the data transferred and the application object.	U32	0-0xFFFFFFFF	0x21000220 (Viscosity in cSt)	0x1A00	0x01	RW	Y
PDO Mapping Entry _2	Mapping between the data transferred and the application object.	U32	0-0xFFFFFFFF	0x21000110 (Viscosity Status)	0x1A00	0x02	RW	Y
Transmit PDO Communication Parameter #1	Defines the parameters the device can transmit. 0x00 is the number of entries.	U8	0x02-0x06	6	0x1801	0x00	RO	N
COB-ID	Communication object identifier	U32	1x0-FFFFFFFF	0x4000180 + \$NODEID	0x1801	0x01	RW	Y
Transmission Type	Specifies the transmission mode and triggering mode.	U8	0-0xFF	0xFF (Event Driven)	0x1801	0x02	RW	Y
Inhibit Time	Minimum time between attempts to transmit.	U16	0-0xFFFF	0x0000	0x1801	0x03	RW	Y
Compatibility Entry	reserved	U8	0-0xFF	0	0x1801	0x04	RW	N
Event Timer	(Event Driven) How often to transmit.	U16	0-0xFFFF	0x0E8 (1 sec)	0x1801	0x05	RW	Y
SYNC start value	Used for SYNC mode.	U8	0-0xFF	0	0x1801	0x06	RW	Y
Transmit PDO Mapping Parameter #0	Defines the parameters the device can transmit. 0x00 is the number of entries.	U8	0-0xFF	2	0x1A01	0x00	RW	N
PDO Mapping Entry _1	Mapping between the data transferred and the application object.	U32	0-0xFFFFFFFF	0x21000220 (Viscosity in cP)	0x1A01	0x01	RW	Y
PDO Mapping Entry _2	Mapping between the data transferred and the application object.	U32	0-0xFFFFFFFF	0x21000110 (Viscosity Status)	0x1A01	0x02	RW	Y

Table F-4: CAN Parameters, TPDOs #2 & #3

Name	Description	Type	Range	Default	Index	Sub	Access	EEPROM
Transmit PDO Communication Parameter #0	Defines the parameters the device can transmit. 0x00 is the number of entries.	U8	0x02-0x06	6	0x1802	0x00	RO	N
COB-ID	Communication object identifier	U32	1x0-FFFFFFFF	0x40000380 + \$NODEID	0x1802	0x01	RW	Y
Transmission Type	Specifies the transmission mode and triggering mode.	U8	0-0xFF	0xFF (Event Driven)	0x1802	0x02	RW	Y
Inhibit Time	Minimum time between attempts to transmit.	U16	0-0xFFFF	0x0000	0x1802	0x03	RW	Y
Compatibility Entry	reserved	U8	0-0xFF	0	0x1802	0x04	RW	N
Event Timer	(Event Driven) How often to transmit.	U16	0-0xFFFF	0x0E8 (1 sec)	0x1802	0x05	RW	Y
SYNC start value	Used for SYNC mode.	U8	0-0xFF	0	0x1802	0x06	RW	Y
Transmit PDO Mapping Parameter #0	Defines the parameters the device can transmit. 0x00 is the number of entries.	U8	0-0xFF	2	0x1A02	0x00	RW	N
PDO Mapping Entry _1	Mapping between the data transferred and the application object.	U32	0-0xFFFFFFFF	0x21000420 (Viscosity in cup-sec)	0x1A02	0x01	RW	Y
PDO Mapping Entry _2	Mapping between the data transferred and the application object.	U32	0-0xFFFFFFFF	0x21000110 (Viscosity Status)	0x1A02	0x02	RW	Y
Transmit PDO Communication Parameter #1	Defines the parameters the device can transmit. 0x00 is the number of entries.	U8	0x02-0x06	6	0x1803	0x00	RO	N
COB-ID	Communication object identifier	U32	1x0-FFFFFFFF	0x40000480 + \$NODEID	0x1803	0x01	RW	Y
Transmission Type	Specifies the transmission mode and triggering mode.	U8	0-0xFF	0xFF (Event Driven)	0x1803	0x02	RW	Y
Inhibit Time	Minimum time between attempts to transmit.	U16	0-0xFFFF	0x0000	0x1803	0x03	RW	Y
Compatibility Entry	reserved	U8	0-0xFF	0	0x1803	0x04	RW	N
Event Timer	(Event Driven) How often to transmit.	U16	0-0xFFFF	0x0E8 (1 sec)	0x1803	0x05	RW	Y
SYNC start value	Used for SYNC mode.	U8	0-0xFF	0	0x1803	0x06	RW	Y
Transmit PDO Mapping Parameter #0	Defines the parameters the device can transmit. 0x00 is the number of entries.	U8	0-0xFF	2	0x1A03	0x00	RW	N
PDO Mapping Entry _1	Mapping between the data transferred and the application object.	U32	0-0xFFFFFFFF	0x21000220 (Temperature in °C)	0x1A03	0x01	RW	Y
PDO Mapping Entry _2	Mapping between the data transferred and the application object.	U32	0-0xFFFFFFFF	0x21000110 (Temperature Status)	0x1A03	0x02	RW	Y

Table F-5: Application Parameters, Viscosity

Name	Description	Data Type	Range	Default	CANopen		Access	EEPROM	PDO
					Index	Sub			
Viscosity	0x00 = Number of objects	U8	1-5	5	0x2100	0x00	RO	N	N
Viscosity Status	See Status Bit Map	U16	0-0xFFFF	0	0x2100	0x01	RO	N	Y
VcSt	Viscosity in centiStokes	REAL32	>=0	0	0x2100	0x02	RO	N	Y
VcP	Viscosity in centiPoise	REAL32	>=0	0	0x2100	0x03	RO	N	Y
Vcup	Viscosity in Cup-seconds	REAL32	>=0	0	0x2100	0x04	RO	N	Y
Density	The density [g/cm ³] used to convert from VcSt to VcP	REAL32	0-10	0.9	0x2100	0x05	RW	Y	N
Stability Settings	0x00 = Number of objects	U8	1-4	4	0x2200	0x00	RO	N	N
Arraysize	Size of the array used for testing stability and updating the viscosity	U16	2-1000	60	0x2200	0x01	RW	Y	N
StableCriteria	The largest acceptable Delta	REAL32	1-5000	500	0x2200	0x02	RW	Y	N
Counter	Current count of viscosity readings in the array.	U16	1 to Array Size	0	0x2200	0x03	RO	N	N
Delta	Difference between the highest and the lowest viscosity reading currently within the array.	REAL32	>=0	0	0x2200	0x04	RO	N	N
CupIndex	Index of the cup (see Cup Table). The index determines the initial K and C values used in CupCalibration.	U8	0-46	0 (= Custom)	0x2300	0x00	RW	Y	N
Custom Cup	0x00 = Number of objects	U8	1-2	2	0x2301	0x00	RO	N	N
Kcust	Initial K value used in the CupCalibration if a custom cup is used (CupIndex = 0)	REAL32	>=0	0	0x2301	0x01	RW	Y	N
Ccust	Initial C value used in the CupCalibration if a custom cup is used (CupIndex = 0)	REAL32	>=0	0	0x2301	0x02	RW	Y	N
Cup Calibration points	0x00 = Number of objects	U8	1-2	2	0x2302	0x00	RO	N	N
V2	Average Viscosity reading in cSt which is recorded at the time that T2 is received. Used in CupCalibration.	REAL32	>=0	0	0x2302	0x01	RO	Y	N
T2	User-entered viscosity value in Cup-seconds. Used in CupCalibration.	REAL32	>=0	0	0x2302	0x02	RW	Y	N
V1	Average Viscosity reading in cSt which is recorded at the time that T1 is received. Used in CupCalibration.	REAL32	>=0	0	0x2302	0x03	RO	Y	N
T1	User-entered viscosity value in Cup-seconds. Used in CupCalibration.	REAL32	>=0	0	0x2302	0x04	RW	Y	N
Cup Conversion Factors	0x00 = Number of objects	U8	1-2	2	0x2303	0x00	RO	N	N
Kadj	Final K value from the CupCalibration. Used to convert VcSt to Vcup.	REAL32	>=0	0	0x2303	0x01	RO	Y	N
Cadj	Final K value from the CupCalibration. Used to convert VcSt to Vcup.	REAL32	>=0	0	0x2303	0x02	RO	Y	N

Table F-6: Application Parameters, Temperature & Relays

Name	Description	Data Type	Range	Default	CANopen		Access	EEPROM	PDO
					Index	Sub			
Temperature	0x00 = Number of objects.	U8	1-4	4	0x2400	0x00	RO	N	N
Temperature Status	See Status Bit Map	U16	0-0xFFFF	0	0x2400	0x01	RO	N	Y
T°C	Temperature in Celsius	REAL32	-20°C to +220°C	0	0x2400	0x02	RO	N	Y
T°F	Temperature in Fahrenheit	REAL32	-20°C to +220°C	0	0x2400	0x03	RO	N	Y
T°K	Temperature in Kelvin	REAL32	-20°C to +220°C	0	0x2400	0x04	RO	N	Y
Relay 1	0x00 = Number of objects.	U8	0-3	3	0x2500	0x00	RO	N	N
Mode	Relay 1 Mode	U8	0-3	0	0x2500	0x01	RW	Y	N
Time Period	Relay 1 Time, in 0.01 secs.	U16	200-65535	2000	0x2500	0x02	RW	Y	N
Duty Cycle	Relay 1 Duty Cycle, in 0.01%	U16	0-10000	0	0x2500	0x03	RW	Y	N
Relay 2	0x00 = Number of objects	U8	0-3	3	0x2501	0x00	RO	N	N
Mode	Relay 2 Mode	U8	0-3	0	0x2501	0x01	RW	Y	N
Time Period	Relay 2 Time Period, in 0.01 secs	U16	200-65535	2000	0x2501	0x02	RW	Y	N
Duty Cycle	Relay 2 Duty Cycle, in 0.01%	U16	0-10000	0	0x2501	0x03	RW	Y	N

Appendix G - Cup Calibration

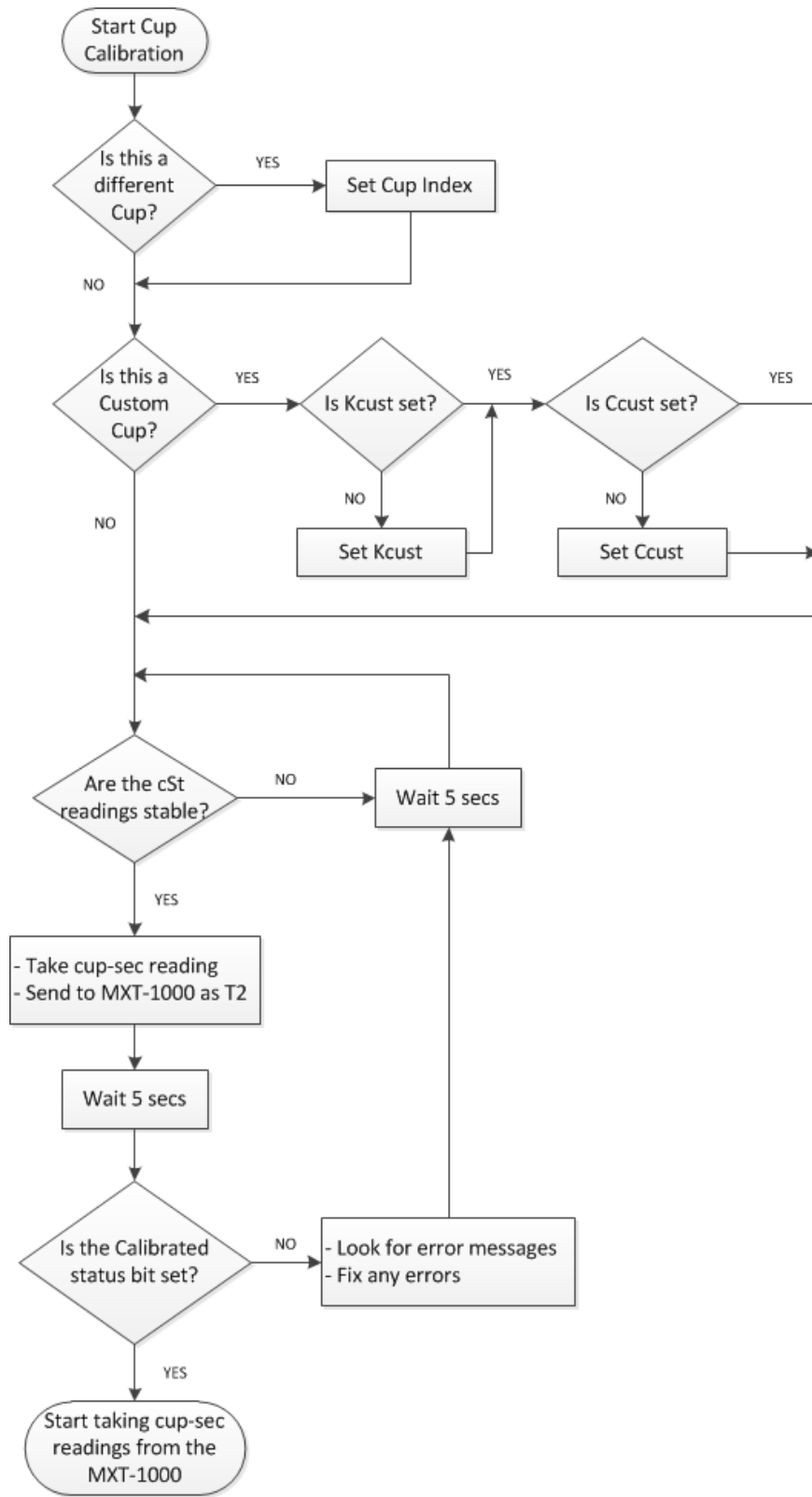

Figure G-1: Cup Calibration Flow Chart

Table G-1: Cup Table

Index	Cup Name	K	C	T₁
1	EZ #1	0.87	993	33.688
2	EZ #2	2.8	747	16.334
3	EZ #3	10.0	587	7.627
4	EZ #4	13.2	673	7.124
5	EZ #5	23.5	744	5.620
6	Zahn #1	1.59	1070	25.941
7	Zahn #2	4.18	760	13.484
8	Zahn #3	10.2	575	7.497
9	Zahn #4	15.1	545	6.002
10	Zahn #5	27.2	540	4.450
11	Mini Ford Dip #0	0.26	157	24.295
12	Mini Ford Dip #1	0.74	300	20.080
13	Mini Ford Dip #2	2.48	385	12.460
14	Mini Ford Dip #3	4.62	275	7.715
15	Mini Ford Dip #4	7.4	200	5.199
16	Mini Ford Dip #5	23.6	204	2.940
17	Standard Ford Dip	2.31	550	15.430
18	Standard Ford Dip	3.7	400	10.398
19	Standard Ford Dip	11.8	408	5.880
20	Mini ISO Dip 3 mm	0.88	100	10.624
21	Mini ISO Dip 4 mm	2.74	100	6.041
22	Mini ISO Dip 6 mm	13.8	285	4.544
23	Mini DIN Dip 4 mm	9.14	226	4.973
24	Fisher Dip #1	0.85	175	14.349
25	Fisher Dip #2	2.23	190	9.050
26	Fisher Dip #3	5.39	185	5.859
27	Fisher Dip #4	18.9	210	3.333
28	Standard Ford #0	0.13	313	48.512
29	Standard Ford #1	0.37	600	40.161
30	Standard Ford #2	1.24	770	24.919
31	Standard Ford #3	2.31	550	15.430
32	Standard Ford #4	3.7	400	10.398
33	Standard Ford #5	11.8	408	5.880
34	ISO 3 mm	0.44	200	21.248
35	ISO 4 mm	1.37	200	12.082
36	ISO 6 mm	6.9	570	9.089
37	ISO 8 mm	21.7	306	3.748
38	Standard DIN 4 mm	4.57	452	9.945

Index	Cup Name	K	C	T_r
39	Fisher #1	0.85	175	14.349
40	Fisher #2	2.32	190	9.050
41	Fisher #3	5.39	185	5.859
42	Fisher #4	18.9	210	3.333
43	Parlin #1	1.55	800	22.718
44	Parlin #2	4.82	100	4.555
45	Parlin #3	20.7	500	4.909

Appendix H - Status Byte Map

VISCOSITY STATUS		
<u>Upper Error Byte</u>	1 =	0 =
bit 7	Reserved for Manufacturer's Use	
bit 6	cSt Reading Out of 4-20mA Range	cSt Reading in 4-20mA Range
bit 5	Cup Calibration Error	No Cup Calibration Error
bit 4	Reserved for Manufacturer's Use	
bit 3	Reserved for Manufacturer's Use	
bit 2	Reserved for Manufacturer's Use	
bit 1	Reserved for Manufacturer's Use	
bit 0	Reserved for Manufacturer's Use	
<u>Lower Status Byte</u>	1 =	0 =
bit 7	Reading is Stable	Reading is not Stable
bit 6	Reading Array is Full	Reading Array is Not Full
bit 5	System is Calibrated to Current Cup	System is Not Calibrated to Current Cup
bit 4	Reserved for Manufacturer's Use	
bit 3	Reserved for Manufacturer's Use	
bit 2	} Probe Parameter Source: 00 = SD Card ; 01 = 1 wire EEPROM	
bit 1	} 10 = Internal Memory	
bit 0	Reserved for Manufacturer's Use	

TEMPERATURE STATUS		
<u>Upper Error Byte</u>	1 =	0 =
bit 7	RTD Probe Not Connected (ADC = Max)	RTD Probe Connected (ADC < Max)
bit 6	RTD Temperature Out of Range	RTD Temperature in Range
bit 5	°C Reading Out of 4-20mA Range	°C Reading in 4-20mA Range
bit 4	Reserved for Manufacturer's Use	
bit 3	Reserved for Manufacturer's Use	
bit 2	Reserved for Manufacturer's Use	
bit 1	Reserved for Manufacturer's Use	
bit 0	Reserved for Manufacturer's Use	
<u>Lower Status Byte</u>	1 =	0 =
bit 7	Reserved for Manufacturer's Use	
bit 6	Reserved for Manufacturer's Use	
bit 5	Reserved for Manufacturer's Use	
bit 4	Reserved for Manufacturer's Use	
bit 3	Reserved for Manufacturer's Use	
bit 2	Reserved for Manufacturer's Use	
bit 1	Reserved for Manufacturer's Use	
bit 0	Reserved for Manufacturer's Use	

Appendix I - Resolving Status Byte Issues

Status Description	Resolution
Cup Calibration Error	<ol style="list-style-type: none"> 1. Make sure that the reading is Stable 2. Make sure that the T2 entered is greater than the T1 for that cup (see Appendix B) 3. If using a Custom Cup (Cup Index = 0), make sure that K_{cust} and C_{cust} are defined.
System is Not Calibrated to Current Cup	<p>The Status will read Not Calibrated under the following conditions:</p> <ol style="list-style-type: none"> 1. On Device power up. 2. If the Cup Index is changed. 3. If a calibration has been started but is not yet complete. <p>In all of these cases, successfully completing a calibration will change the Status to Calibrated.</p>
Reading is Not Stable	<ol style="list-style-type: none"> 1. The reading is considered Not Stable if the Reading Array is not yet Full. 2. Once the Reading Array is Full, the readings are still considered Not Stable if their values vary more than allowed by the Stability Criteria.
Reading Array is Not Full	The Reading Array is empty when either the device is powered up or the Array Size (in sec) is changed. Make sure that enough time has elapsed since then for the Reading Array to fill back up.

Resolving CAN Error Messages

Data	Error Description	Resolution
80 xx xx xx 02 00 01 06	Attempt to write to a read only object.	Check the index and sub-index portion of the command sent.
80 xx xx xx 00 00 02 06	Object does not exist in the object dictionary.	
80 xx xx xx 11 00 09 06	Sub-index does not exist.	
80 xx xx xx 31 00 09 06	Value of parameter written too high.	Check the value sent against the allowed range.
80 xx xx xx 32 00 09 06	Value of parameter written too low.	
Note: xx xx xx are the index and sub-index of the parameter being written, the same index and sub-index that was in the corresponding command sent.		

Appendix J - Warranty Information

We hereby warranty this Brookfield Viscometer to be free from defects in workmanship and materials. If found to be defective in workmanship or materials up being returned, within one year from the date of purchase to our factory, it will be repaired or replaced at the factory without charges. Transportation charges shall be at the owner's expense.

However, if upon being so returned and after inspection, we determine that the instrument has been subjected to tampering, careless handling, improper or faulty application or installation, the above guarantee shall not be applicable and we shall have the right in any case to make a charge to cover the cost of repairs or servicing. AMETEK Brookfield assumes and shall have no liability for consequential damages resulting from the use or misuse of the instrument.

The foregoing warranty is in lieu of all other guarantees or warranties, expressed or implied, and of all other obligations or liabilities, contractual or otherwise, either to the original purchaser of said instrument or to any other person whomsoever.

Appendix K - Customer Support & Repair

Use the following information to contact Brookfield for technical assistance or service:

AMETEK Brookfield
11 Commerce Boulevard
Middleboro, Massachusetts 02346 U.S.A.
TEL: 508-946-6200; 800-628-8139 (USA only)
FAX: 508-946-6262
EMAIL: MA-MID.sales@ametek.com

Please have the following information available when calling so that we may assist you:

- Product Part Number
- Product Serial Number
- Product Application
- Specific Problem Area
- Hours of Operation
- Equipment Type

Instrument Repair Procedure and Guidelines

The MXT Transmitter is a highly reliable and rugged unit that requires little maintenance. This section provides information on component replacement.

In the event that your Process Viscometer should require factory maintenance, AMETEK Brookfield has provided the following guidelines and recommendations to follow to ensure a prompt turn around time for all repaired items.

Before returning any Brookfield Process Viscometer, please contact our Process Service/Sales Department to obtain a Return Authorization Number. This will ensure that your instrument is routed to the proper Repair Department when received. Unnecessary delays may result when “unannounced” repairs arrive at our facility and have to be sorted and routed outside standard procedures. To contact the Process Service/Sales Department, please call 508-946-6200 or 800-628-8139 (USA Only); or you may prefer to email us at MA-MID.sales@ametek.com.

Please be sure to follow these guidelines when returning your instrument:

1. Make sure the Return Repair Form received from us is completely filled out with the correct information.
2. Ensure that the MSDS section of the Return Repair Form is completed and any applicable MSDS sheets are also included with your instrument to be repaired. Failure to comply with MSDS regulations may result in repair delays.
3. Including a Purchase Order with your Repair Form will allow us to complete repairs to a specified dollar amount determined by the product type, and thereby, bypassing the need to complete an “Estimate of Repair” to submit for your approval. If you wish to be informed of repair cost before proceeding, please specify on the Repair Form.
4. Our method of return shipment is via FedEx. Should you prefer a different method or wish to charge to your carrier account number, be sure to include this information.

