

Data Sheet

J. M. CANTY FUSEVIEW™

ANSI/DIN Sight Glass



Supplied by

247able.com

Call us on +44 (0)118 916 9420 | Email info@247able.com

CANTY

PROCESS TECHNOLOGY

FUSEVIEW™ ANSI/DIN SIGHT GLASS

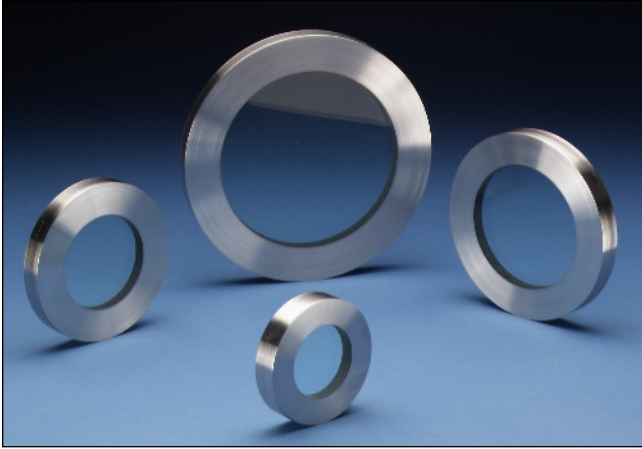

THE CANTY ADVANTAGE

Canty Fuseview™ sight glasses have been engineered to meet all your process and safety needs. All standard Fuseviews™ feature Factory Mutual approval and were designed and tested to ensure the safest product available. Canty can provide certification of material and testing if required, typical of ASME code requirements for process vessels.

UNMATCHED SAFETY, RELIABILITY

All Canty sight glasses feature the Fuseview™ window. Our unique fused glass windows far exceed all conventional tempered glass windows in safety and performance. By fusing glass to metal, a high pressure, high safety, hermetic seal is formed. The fused glass technology ensures safety with every Fuseview™. What's more, our windows can easily be removed for cleaning. Canty windows do not have to be discarded, as do traditional tempered glass windows. Canty fused glass windows can be re-used again and again.

ADVANTAGES OF THE FUSEVIEW™

- Standard models feature FM approval!
- Extremely high strength due to radial compression on the hermetically sealed glass
- Eliminates chance of catastrophic failure due to bolt-up
- Very high impact strength and thermal shock resistance due to prestressing
- Operates under positive or negative pressure

All registered trademarks are the property of their respective owners.

FEATURES

- Stainless, carbon, Alloy C, Hastelloy® C276 or equal, and Hastelloy® C-22® or equal fusing rings
- 150# through 2500#, 10 bar through 40 bar models
- Special pressures through 10,000 PSI are available
- Standard temperatures to 650°F [343°C], specials to 2000°F
- Specials available to retrofit any existing sight glass
- Quartz and Sapphire shields for caustic service
- Glass wetted models for glass lined vessels Straight or NPT threaded Fuseviews™ available

CANTY FUSEVIEW™ VS METALGLASS

- Largest view in the Industry. When you order a 4" window you get a 4" view!
- Fuseviews™ are made with excellent corrosion resistant high nickel Alloy C, Hastelloy® C276 or equal, C-22® or equal, not duplex stainless steels.
- Boro Plus™ fused glass is superior to other glass with ideal optical and fusing properties. It readily fuses to steel making a one piece hermetically sealed window capable of high pressures and temperatures.
- Ideal properties of metal and glass provides true fusion of glass to metal. This provides a stronger safer fuse that will not crack during installation or operation like borosilicate and duplex stainless steels.
- Superior impact, thermal shock, and pressure resistance from the use of optimum materials and the proper fusing process during manufacturing.

CANTY FUSEVIEW™ VS OTHERS

- No bolt loading on glass. The load is carried by the fusing ring so you can use the torque you need for your process.
- The Fuseview™ allows the use of standard process gasketing. No special gaskets are required.
- Canty Fuseviews™ may be removed for cleaning and inspection. This is not allowed with ordinary glass, due to residual stresses incurred at bolt-up.
- No loss of glass temper over time!
- Scratches do not affect safety or life.
- Unlike tempered glass, a Fuseview™ will not blow out if the surface is damaged.
- No shims, packing, or adjusting screws
- Canty mounts to standard ANSI or DIN dimensions

UNIQUE OPTIONS

- Dual fused glass for high temperature applications
- Lighting - Flex bundle light eliminates a second nozzle
- Canty Jet spray ring for cleaning or cooling Tri-clamp® sanitary one piece Fuseview™

CANTY

Buffalo, NY USA

Dublin, Ireland

Phuket, Thailand

www.jmcanty.com

Ph: (716) 625 4227

Ph: + 353 (01) 882 9621

Ph: + 66 (83) 968 9548

Document P/N: TA7652-1 Rev 7

FUSEVIEW™ SIGHT GLASS SPECIFICATIONS

ANSI Dimensions

SIZE	A	VIEW B	PRESSURE RATING PSI	TEMP RATING °F
1"	2.00"	1.13"	150/300/600	450
1.5"	3.00"	1.50"	150/300/600	450
2"	3.62"	2.13"	150/300/600	450
2.5"	4.00"	2.50"	150/300/600	450
3"	5.00"	3.00"	150/300/600	450
3.5"	5.50"	3.50"	150/300/600	450
4"	6.00"	4.00"	150/300/600	450
5"	7.50"	5.00"	150/300/600	450
6"	8.37"	6.00"	150/300/600	450
8"	10.50"	8.00"	150/300	400
10"	12.00"	9.50"	50	300

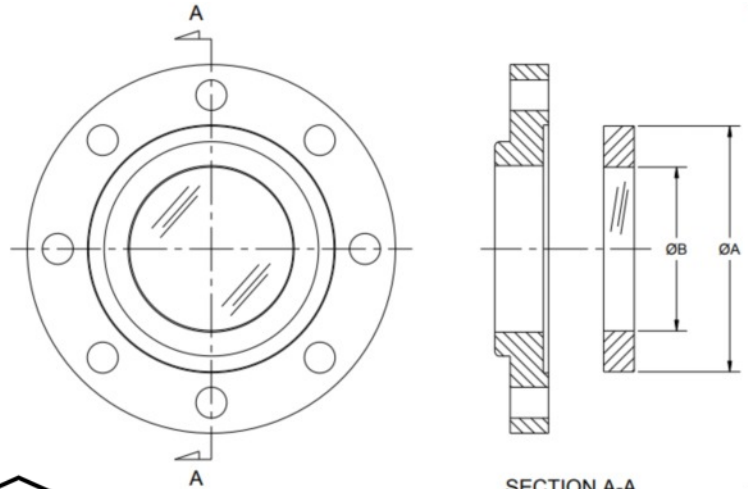

DIN Dimensions

SIZE mm	A mm	VIEW B mm	PRESSURE RATING BAR	TEMP RATING °C
25	68	38	10/16/25/40	232
32	76	38	10/16/25/40	232
40	88	51	10/16/25/40	232
50	92	54	10/16/25/40	232
65	122	76	10/16/25/40	232
80	127	76	10/16/25/40	232
100	152	102	10/16/25/40	232
125	191	127	10/16/25/40	232
150	213	152	10/16/25/40	232
200	267	203	10/16	204
250	305	241	3.5	150

Retrofit Cartridge Dimensions

SIZE	A	VIEW B	PRESSURE RATING PSI	TEMP RATING °F
2"	3.00"	2.00"	150/300/600	450
2.5"	4.50"	2.50"	150/300/600	450
3"	4.80"	3.00"	150/300/600	450
4"	5.90"	4.00"	150/300/600	450
4.5"	6.50"	4.50"	150/300/600	450
4.5"	6.75"	4.50"	150/300/600	450
4.5"	6.89"	4.50"	150/300/600	450
4.5"	7.00"	4.50"	150/300/600	450
5.6"	7.87"	5.60"	150/300	450
7.0"	9.50"	7.00"	150/300	400
7.3"	9.81"	7.30"	150/300	400

Ordering Information

HOW TO ORDER: Select the appropriate symbols and build a part number as shown:

EXAMPLE:

S1 - - - 1 - - - A0

PRESSURE:

A = 150 PSI 1 = 10 BAR
 B = 300 PSI 2 = 16 BAR
 D = 600 PSI 3 = 40 BAR

SIZE:

ANSI	DIN	Retrofit (No retainer only)
B = 1.0"	X = 25mm	D = 2.0" x 3.0"
C = 1.5"	Y = 32mm	G = 2.5" x 4.5"
E = 2.0"	Z = 40mm	9 = 3.0" x 4.8"
F = 2.5"	1 = 50mm	K = 4.0" x 5.9"
H = 3.0"	2 = 65mm	L = 4.5" x 6.5"
J = 4.0"	3 = 80mm	M = 4.5" x 6.75"
P = 5.0"	4 = 100mm	N = 4.5" x 6.89"
R = 6.0"	5 = 125mm	O = 4.5" x 7.0"
V = 8.0"	6 = 150mm	Q = 5.6" x 7.87"
W = 10.0"	7 = 200mm	S = 7.0" x 9.5"
	8 = 250mm	T = 7.3" x 9.81"

RETAINER MATERIAL: (non-wetted)
 0 = No flange
 1 = Carbon Steel
 2 = 316L Stainless Steel

FINISH: (wetted) (non-wetted = 32 µin[.81 µm] Ra)
 0 = 32 µin[.81 µm] Ra (standard)
 B = 20 µin[.51 µm] Ra (BPE-SF1)
 C = 15 µin[.38 µm] Ra
 L = 20 µin[.51 µm] Ra Electropolished (BPE-SF5)
 M = 15 µin[.38 µm] Ra Electropolished (BPE-SF4)

FUSEVIEW™ MATERIAL: (wetted)
 A = Carbon Steel
 B = 316L Stainless Steel*
 C = Alloy C
 D = Hastelloy® C276 or equal
 E = Hastelloy® C22® or equal

All registered trademarks are the property of their respective owners.

* Canty reserves the right to upgrade to Hastelloy® C-family of alloys or equal at their own cost.